



JONNESWAY®

PROFESSIONAL TOOL SERIES

CATALOGUE 2017/18

EDITION 6





JONNESWAY® with over 34 years of experience in the field of hand tools, air tools, automotive and repair tools has again advanced to the next level of excellence. Our products not only meet strict quality requirements by professional markets, but also received patents on many new advanced designs. We have established strong distribution networks around the world.

Currently there are more than 4000 JONNESWAY® dealers in 102 countries, including U.S.A., Russia & C.I.S., Poland, Portugal, South Africa, Norway, Denmark, Sweden, Finland, Middle East, Asia...etc. Jonnesway has five advantages to achieve ultimate goal as:

COMPLETE RANGE OF JONNESWAY PROFESSIONAL TOOLS

1. Jonnesway Professional Hand Tools
2. Jonnesway Professional Pneumatic Tools
3. Jonnesway Professional Spray Gun and Sander Series
4. Jonnesway Professional Automotive Repair and Garage Equipment
5. Jonnesway Professional Tool Trolleys with Mechanic Tool Sets

PROMISED HIGH QUALITY

All of Jonnesway tools meet the international standard, many even exceeds the Germany DIN and American ANSI.

PROVIDE EXPERIENCED SUPPORT AND TECHNICAL SERVICES

Jonnesway provides support with experience and technical know-how to facilitate our distributors to establish loyal customers and to attract new customers by providing excellent after-market service.

GUARANTEED HIGH-QUALITY AND SUPERB INNOVATION

With higher quality and greater function, Jonnesway R&D aims to achieve industrial safety, environmental friendly and user friendly design, to ensure our distributors' leading position in the market, as well as to stimulate new demands and increase turnover.

OFFER COMPETITIVE PRICE

Jonnesway offers the same or even better qualities as compared to other internationally famous brands, but at a competitive price in order to create more profits for our distributors.



SURAT KETERANGAN
No: 20/ASS/WAE/SK/IX/2015

Kami selaku Jaguar – Land Rover Authorized Workshop PT. Wahana Auto Ekamarga menerangkan bahwa terhitung dari tahun 2006 telah menggunakan General Tools, Pneumatic Tools, Repair Tools dan Automotive Tools merek “JONNESWAY” yaitu untuk Technical Training maupun di Workshop Jaguar – Land Rover.

Untuk seluruh Jaguar – Land Rover Authorized Workshop kami juga merekomendasikan untuk menggunakan produk “JONNESWAY” sebagai Supporting Tools utama workshop.

Pilihan kami menggunakan produk “JONNESWAY” dikarenakan kualitas yang baik, harga yang kompetitif, serta didukung dengan long life warranty dan layanan purna jual yang memuaskan.

Berkat dukungan pelayanan purna jual dari PT. Prima Teknik Mandiri selaku Distributor Tunggal produk tools merek “JONNESWAY” yang kami gunakan masih berfungsi dengan baik hingga saat ini.

Demikian surat keterangan ini kami buat untuk dapat digunakan sebagaimana mestinya.

Jakarta, September 2015

Hormat Kami,

Faried Harivanto
GM Aftersales

Recommendation
JONNESWAY received the Recommendation Letter from JAGUAR Indonesia in 2015



Citroën S.A.
 Technical Training Department
 47 New Market Drive
 Northriding
 Johannesburg
 South Africa
 011 462 4200

03 June 2008

Herewith I would like to confirm that Citroën S.A. has been utilizing the Jonnesway products for the past 3 years in our Training Centre. We are more than satisfied with the quality of tools and the outstanding back up service we have received to date.

We recommend them as our tool supplier of choice.

Should you require any further information please do not hesitate to contact me?

Kind Regards

Steven Terblans

Technical Training Manager

Recommendation
JONNESWAY received the Recommendation Letter from CITROËN South Africa in 2008

Peugeot Motors South Africa
 PO Box 389
 Kelvin
 2054

20 June 2008

To whom this may concern.

Re : Jonnesway Tools supplied by Gondolier



Up to now we have always received exceptional service from both Jonnesway and Gondolier and we are totally satisfied with the quality of Jonnesway tools. It is only a pleasure to recommend both Jonnesway and Gondolier as a preferred supplier of tools.

For an on behalf of PMSA Training Centre,

Hereby I would like to confirm that Peugeot Motors South Africa has been utilizing Jonnesway Tools for the passed 2 years in both our Technical Training Centre and Peugeot Assist Vehicles.

Jaco Mare
 Training Centre Manager

Recommendation
JONNESWAY received the Recommendation Letter from PEUGEOT South Africa in 2008



SUZUKI SOUTH AFRICA (PTY) LTD

Co. Reg. number 1998/14138/07
P.O. Box 823
Isando 1600
South Africa

June 302008
Ref. 2271/08/JM

JONNESWAY TOOLS

To Whom It May Concern:

Suzuki South Africa is proud to have Jonnesway Tools as our supplier of professional hand tools for use in our Technical Training centre and Workshops.

This has been an ideal opportunity for Suzuki South Africa to be associated with a leading brand like Jonnesway, who's product range and quality are second to none.

Jonnesway Tools are also sponsors and suppliers to the Brad Anassis - Suzuki National Road Racing and Drag Racing Teams.

Yours truly,

Errol Quan Chai
Technical Manager

Directors: D VAN VUUREN DX MOORKENS* (Managing) (Belgium)*

Recommendation
JONNESWAY received the Recommendation Letter from SUZUKI South Africa in 2008



PT RESTU MAHKOTA KARYA
Authorized SUZUKI Dealer

SURAT KETERANGAN

No : RMK-SRV/Ext/1/2016/001

Bersama ini kami selaku Suzuki Authorized Dealer PT. Restu Mahkota Karya - Group menerangkan bahwa terhitung sejak tahun 2013 telah menggunakan General Tools, Repair Automotive Tools merek "JONNESWAY" sebagai Supporting Tools di Workshop kami.

Kami memilih menggunakan Tools produk "JONNESWAY" karena kualitasnya baik, harga kompetitif dan dukungan purna jual yang terjamin serta ada jaminan long life warranty dan pengajuan claimnya mudah.

Berkat dukungan pelayanan yang baik dari PT. Prima Teknik Mandiri selaku Distributor Tunggal produk tools merek "JONNESWAY" operasional di workshop kami tidak mengalami kendala hingga saat ini.

Demikian surat keterangan ini kami buat untuk dapat digunakan sebagaimana mestinya.

Jakarta, 14 Januari 2016

Hormat kami

PT RESTU MAHKOTA KARYA
Budiono P
GM After Sales

We, PT. Restu Mahkota Karya - Group, as Suzuki Authorized Dealer, would hereby like to state that as of year 2013, we have been using General Tools, Repair Tools and Automotive Tools "JONNESWAY" Brand as a Supporting Tools for our Workshop.

The reason we choose "JONNESWAY" is because its Good Quality, Competitive Pricing and also backed with Long Life Warranty, satisfactory After Sales service, and easy procedure for claim.

Because of the After Sales service provided by PT Prima Teknik Mandiri, as the Sole Distributor for "JONNESWAY" in Indonesia, the tools we have been using are still functional and are in good condition until now.

With this letter, we hope that it has been used for as it is intended for.

Jakarta, January 14th, 2016

Best Regards,

Budiono P
GM After Sales

Head Office : Jl. Panjang No. 12 Kebon Jeruk, Jakarta Barat Telp : (021) 533 2020 (Hunting) Fax : (021) 533 2142, 533 2143 Email : operational@rmk.co.id

Branch Office :
DKI Jakarta 1. Kebon Jeruk : Jl. Panjang No.12 Jakarta Barat, Showroom Telp : (021) 533 2020 Workshop Telp. (021) 549 2727, 2.Rory : Jl. KH. Hasyim Ashari 11 ABC Jakarta Pusat Telp. (021) 633 2323, 633 2424, 3. Tanah Abang Jl. KS Tubun No. 21, Petamburan Showroom Telp. (021) 548 5815 Fax. (021) 549 2307 Banten 1. Tangerang : Jl. Merdeka 1, Cimone Showroom Telp. (021) 551 7877, 552 5340 Workshop Telp. (021) 551 7876, 2. Cilegon : Jl. Raya Serang Km. 1 Cibeter Showroom (0254) 381 500 Workshop Telp (0254) 380 961, 3. Rangkas Bitung : Jl. Gugur By pass Mandala Showroom Telp. (0252) 203 947, 4. Ciledug : Jl. K.H. Hasyim Ashari 82 Pinang Showroom Telp. (021) 730 7999 Workshop Telp : (021) 731 3023, 5. Pandeglang : Jl. Raya Labuan Km. 4 Cipacung Showroom Telp. (0253) 201 345, Jawa Barat 1. Karawang : Jl. Jend. A. Yani 36 Showroom Telp : (0267) 403 482 Workshop Telp (0267) 403 084, 403 485, 2. Purwakarta : Jl. Basuki Rahmat 168 Showroom Telp. (0264) 822 6162 Workshop Telp. (0264) 822 6165, 3. Cimanggis : Jl. Raya Bogor Km. 29 Showroom Telp. (021) 8770 8918 Workshop Telp. (021) 8770 8918, 4. Cibadak : Kampung Selawi No.38 Karang Tengah - Sukabumi Showroom Telp. (0266) 537 836 Workshop Telp. (0266) 537 833, 5. Cikampek : Jl. K. Juanda No. 168, Cikampek, Jawa Barat Showroom : (0254) 8296518 (Hunting) Workshop : (0254) 8296511

Recommendation
JONNESWAY received the Recommendation Letter from Indonesia in 2016



**Certificate
ISO 9001: 2008 Certificate**

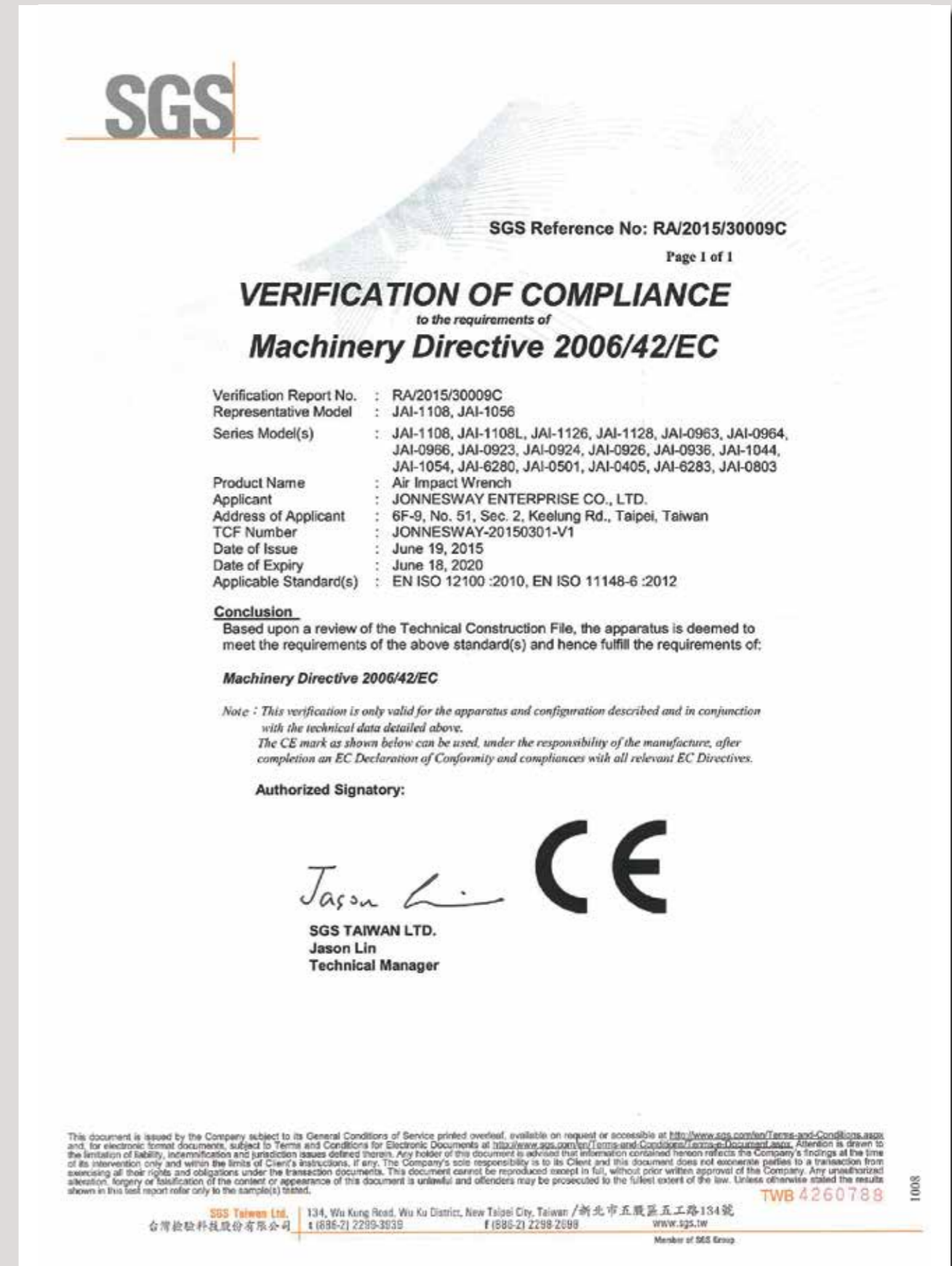

**Certificate
CE Certificate**

VDE Prüf- und Zertifizierungsinstitut

**ZEICHENGENEHMIGUNG
MARKS APPROVAL**

Jonnesway Enterprise
Co. Ltd.
6F-9, No.51, Sec.2, Keelung Rd.
110 TAIPEI
TAIWAN

ist berechtigt, für ihr Produkt /
is authorized to use for their product

Zange, isoliert
Pliers, insulated

die hier abgebildeten markenrechtlich geschützten Zeichen
für die ab Blatt 2 aufgeführten Typen zu benutzen /
the legally protected Marks as shown below for the types referred to on page 2 ff.



Geprüft und zertifiziert nach /
Tested and certified according to

DIN EN 60900 (VDE 0682-201):2013-04; EN 60900:2012

Das Produkt entspricht den Anforderungen des deutschen Produktsicherheitsgesetzes (ProdSG)
hinsichtlich der Gewährleistung von Sicherheit und Gesundheit.
The product covers the requirements of the German Act "Produktsicherheitsgesetz (ProdSG)"
regarding the ensurance of safety and health.



Befristet zum / valid until: 2019-04-30

Aktenzeichen: 5010169-3940-0011 / 199851

VDE Prüf- und Zertifizierungsinstitut GmbH
VDE Testing and Certification Institute
Zertifizierungsstelle / Certification

File ref.: Ausweis-Nr. 40040800 Blatt 1

Certificate No. Page

Weitere Bedingungen siehe Rückseite und Folgeblätter /
further conditions see overleaf and following pages
Offenbach, 2014-09-26
(letzte Änderung / updated 2014-12-05)

VDE Zertifikate sind nur gültig bei Veröffentlichung unter:
VDE certificates are valid only when published on:

<http://www.vde.com/zertifikat>
<http://www.vde.com/certificate>



HAND TOOLS SERIES

- Chrome Vanadium Steel
- Professional Quality ANSI / DIN Standard
- Anti-Slip Grip Patent-Design
- Standard & Stubby Types

CONTENTS

PAGES

TOOL TROLLEY & MECHANIC TOOLS SET	1 - 34
TORQUE WRENCH & RATCHET HANDLE	35 - 41
WRENCH SERIES	42 - 58
SUPER TECH SERIES	59 - 64
SOCKETS SERIES	65 - 95
PLIERS SERIES	96 - 110
SCREWDRIVER SERIES	111 - 118
HEX KEY	119 - 124
HAMMER, CHISEL & PUNCH	125 - 127
CALIPER	128 - 129
MEASURING TAPE & HACKSAW	130
AIR IMPACT WRENCH SERIES	132 - 140
AIR RATCHET, DRILL & SCREWDRIVER SERIES	141 - 146
AIR DIE GRINDER SERIES	147 - 152
AIR SANDER SERIES	153 - 157
AIR SAW & HYDRAULIC RIVETER	158 - 159
AIR BLOW GUN, AIR GREASE GUN & AIR CONTROL UNIT	160 - 161
AUTO AIR HOSE WINDER	162
AIR TOOL ACCESSORIES	163 - 164
SPRAY GUN SERIES	165 - 168
AUTOMOTIVE TOOLS	169 - 214
MERCEDES BENZ REPAIR TOOLS	215 - 222
BMW REPAIR TOOLS	223 - 230
VOLKSWAGEN & AUDI REPAIR TOOLS	231 - 235
VOLVO REPAIR TOOLS	236 - 237
TRUCK SERVICE TOOLS	238 - 239



TOOL TROLLEY & MECHANIC TOOLS SET

- Heavy Duty Work Table With Anti-Vibration Top.
- Specially-Design Side Handle For Holding Tools, Beverages, Fasteners And More.
- Long-Life Drawers With Ball Bearing Slides & A Weight Capacity Of 50 KGS Each.
- 5" x 2" Caster Loading Over 200 lbs Apiece.
- Various Mechanic Tools Sets Design to Satisfy Your Market Demand.

BALL BEARING SLIDES



- Steel thickness: Cabinet-1.0mm drawer, 1.0mm body, 1.2mm top and bottom covers.
- Ball bearing designed for smooth slicing.
- Safe - designed Aluminum end to prevent scratches.
- Internal locking system for extra security.
- One piece steel of Cabinet Body to add more strength.
- 5"x2" Casters
- 200 Lbs loading capacity for each caster



- Tray : EVA Form
- Easy to organize for more efficient management
- Provide complete protection for tools



C-8DW389V 389PCS PROFESSIONAL MECHANIC TOOL SET W/8-DRAWER TOOL TROLLEY



First Drawer

S04H3145SV 145PCS 1/4" & 3/8" SOCKET & TORQUE WRENCH SET

- Contents:

S04H2	10PCS-1/4"DR. 6PT SOCKETS: 5, 5.5, 6, 7, 8, 9, 10, 11, 12, 13MM
S04HD2	10PCS-1/4"DR. 6PT DEEP SOCKETS: 5, 5.5, 6, 7, 8, 9, 10, 11, 12, 13MM
R3702	1PC-1/4"DR. RATCHET HANDLE 48 TEETH
S24H2	2PCS-1/4"DR. EXTENSION BAR
S15H240	1PC-1/4"DR. UNIVERSAL JOINT
S16H1438	1PC-ADAPTER: 1/4"(F) x 3/8"(M)
S26H2120	1PC-1/4"DR. SPINNER HANDLE
S11H2	3PCS-1/4"DR. PHILLIPS BIT SOCKETS: PH.0, PH.1, PH.2
S09H2	5PCS-1/4"DR. HEX BIT SOCKETS: 3, 4, 5, 6, 7MM
S07H2	7PCS-1/4"DR. STAR BIT SOCKETS: T6, T7, T8, T9, T10, T15, T20
S08H2	9PCS-1/4"DR. STAR BIT SOCKETS (TAMPERPROOF): T8H, T9H, T10H, T15H, T20H, T25H, T27H, T30H, T40H
S04H3	16PCS-3/8"DR. 6PT SOCKETS: 8, 9, 10, 11, 12, 13, 14, 15, 16, 17, 18, 19, 20, 21, 22, 24MM
S04HD3	15PCS-3/8"DR. 6PT DEEP SOCKETS: 8, 9, 10, 11, 12, 13, 14, 15, 16, 17, 18, 19, 20, 21, 22MM
S06H	12PCS-STAR SOCKETS: 1/4"DR.- E6, E7, E8, E10 3/8"DR. - E11, E12, E14, E16, E18 1/2"DR. - E20, E22, E24
S06HD	10PCS-STAR DEEP SOCKETS: 1/4"DR.- E4, E5, E6, E7, E8 3/8"DR. - E10, E11, E12, E14, E16
R3703B	1PC-3/8"DR. STUBBY RATCHET HANDLE 48TEETH
R3703	1PC-3/8"DR. RATCHET HANDLE 48 TEETH
R4103	1PC-3/8"DR. FLEXIBLE HANDLE 48 TEETH
T21050N	1PC-3/8"DR. MICROMETER TORQUE WRENCH 10-50 N.M.
S24H3	3PCS-3/8"DR. EXTENSION BAR, L: 75, 150, 250MM
S15H356	1PC-3/8"DR. UNIVERSAL JOINT
S16H403	1PC-ADAPTER 1/2"(F) x 3/8"(M)
S17H3	3PCS-3/8"DR. SPARK SOCKETS: 16, 18, 21 MM
S11H3	2PCS-3/8"DR. PHILLIPS BIT SOCKETS: PH.1, PH.2
S09H3	8PCS-3/8"DR. HEX BIT SOCKETS: 5, 5.5, 6, 7, 8, 9, 10, 12 MM
S07H3	7PCS-3/8"DR. STAR BIT SOCKETS: T20, T25, T27, T30, T40, T45, T50
S08H3	7PCS-3/8"DR. STAR BIT SOCKETS (TAMPERPROOF): T20, T25, T27, T30, T40, T45, T50
S64H3	6PCS-3/8"DR. SPLINE BIT SOCKETS: M5, M6, M8, M9, M10, M12

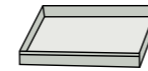

- Tray : EVA Form
- Easy to organize for more efficient management
- Provide complete protection for tools



Second Drawer

S04H4075SV 75PCS 1/2"DR. SOCKET & TORQUE WRENCH SET

- Contents:

S04H4	22PCS-1/2"DR. 6PT SOCKETS : 8, 9, 10, 11, 12, 13, 14, 15, 16, 17, 18, 19, 20, 21, 22, 23, 24, 26, 27, 28, 30, 32 MM
S09H4	8PCS-1/2"DR. HEX BIT SOCKETS : 4, 5, 6, 7, 8, 9, 10, 12 MM (55MML)
S07H4	8PCS-1/2"DR. STAR BIT SOCKETS : T27, T30, T40, T45, T50, T55, T60, T70 (55MML)
S08H4	8PCS-1/2"DR. STAR BIT SOCKETS (TAMPERPROOF) : T27, T30, T40, T45, T50, T55, T60, T70 (55MML)
S64H4	8PCS-1/2"DR. SPLINE BIT SOCKETS : M5, M6, M8, M9, M10, M12, M14, M16 (55MML)
S09H4	4PCS-1/2"DR. HEX BIT SOCKETS : 6, 7, 8, 10, MM (100MML)
S07H4	4PCS-1/2"DR. STAR BIT SOCKETS : T40, T45, T50, T55 (100MML)
S64H4	4PCS-1/2"DR. SPLINE BIT SOCKETS : M6, M8, M10, M12 (100MML)
R3704	1PC-1/2"DR. RATCHET HANDLE 48 TEETH
T21200N	1PC-1/2"DR. MICROMETER TORQUE WRENCH 20-200 N.M.
S24H4	2PCS-1/2"DR. EXTENSION BAR : 125, 250 MML
S15H472	1PC-1/2"DR. UNIVERSAL JOINT
S16H304	ADAPTOR FOR EXTENSION BAR 3/8" (F) x 1/2" (M)
S17H4	3PCS-1/2"DR. SPARK PLUG SOCKETS : 16, 18, 21 MM

Third Drawer

D71P124SV 24PCS SCREWDRIVER SET

- Contents:

D71P	4PCS-PHILLIPS SCREWDRIVER : PH.1 x 80, PH.2 x 38, PH.2 x 100, PH.3 x 125
D71S	5PCS-SLOTTED SCREWDRIVER : 4 x 100, 5.5 x 38, 5.5 x 125, 6.5 x 150, 8 x 175 MM
D71T	12PCS-STAR SCREWDRIVER : T6, T7, T8, T9, T10, T15, T20, T25, T27, T30, T40, T45
D70	3PCS-GO-THRU IMPACT SCREWDRIVER : 6.5 x 125, 8 x 150 MM, PH.2 x 100



Fourth Drawer

W23136SV 36PCS WRENCH SET

- Contents:

W24106S	6PCS-FLARE NUT WRENCH : 8 x 9, 10 x 11, 10 x 12, 13 x 14, 16 x 17, 17 x 19 MM
W26	22PCS-COMBINATION WRENCH : 6, 7, 8, 9, 10, 11, 12, 13, 14, 15, 16, 17, 18, 19, 20, 21, 22, 23, 24, 27, 30, 32 MM
W23	8PCS-75° OFFSET RING WRENCH : 6 x 7, 8 x 9, 10 x 11, 12 x 13, 14 x 15, 16 x 17, 18 x 19, 20 x 22 MM

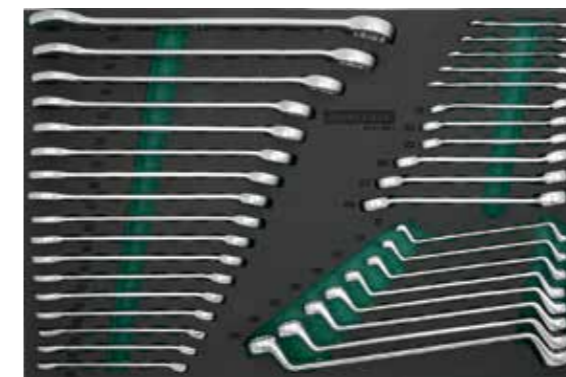



- Tray : EVA Form
- Easy to organize for more efficient management
- Provide complete protection for tools



Fifth Drawer

P08223SV 23PCS PLIERS, HAMMER, FILE & CHISEL SET

• Contents:

P0817	7" COMBINATION PLIERS
P1116	8" LONG NOSE PLIERS
P1218	8" BENT LONG NOSE PLIERS
P1017	7" DIAGONAL PLIERS
P2810	10" WATERPUMP PLIERS
P32M10A	10" LOCKING PLIERS
M61H	2PCS-CHISEL 18X190, 24X220MML
M63H	4PCS-PIN PUNCH 13X150, 4X180, 5X200, 6X210MML
M62H	3PCS-TAPER PUNCH 2X185, 3X185, 4X185MML
M09400	MACHINIST HAMMER 400G
M06025	STONING HAMMER 1000G
MT0701	MEASURING TAPE: 3MX19MM
MK2080	UTILITY KNIFE(18MM BLADE)
MF05A	8" FLAT FILE
MF05B	8" ROUND FILE
MF05C	8" HALF ROUND FILE
MF05E	8" TRIANGLE FILE

Sixth Drawer

S09H4152SV 52PCS INTERNAL & EXTERNAL PLIERS, HAMMER, SOCKET & WRENCH SET

• Contents:

S09H4317	1/2"DR. HEX BIT SOCKET: 17MMX100MML
S09H4806	1/2"DR. HEX BIT SOCKET: 6MMX200MML
S09H4808	1/2"DR. HEX BIT SOCKET: 8MMX200MML
W29	3PCS-STAR WRENCH: E6 X E8, E10 X E12, E14 X E18
RD01032S	32PCS 1/4" HEX MINI RATCHET BIT SET
AG010002SP	4PCS - 7" INTERNAL & EXTERNAL PLIERS SET
S18A4103S	3PCS-1/2" DR. WHEEL NUT IMPACT DEEP SOCKETS: 17, 19, 21MM
M11045	45MM Ø DEAD BLOW HAMMER WEIGHT: 520G
AI050066	3PCS - OIL FILTER CAP WRENCH SET: 27, 32, 36MM
AR060003	SWIVEL JAW HOSE CLAMP PLIERS
AG010188	MAGNETIC PICK-UP TOOL
AI050085A	OIL FILTER WRENCH: 74.4MM X 14 FLUTES

Seventh Drawer

W25134SV 34PCS WRENCH, HEX KEY & HOOK SET

• Contents:

AI030007-A	11" MULTIPURPOSE SCRAPER
AI030007-E	9" COTTER PIN PULLER
AB030045	DOOR UPHOLSTERY REMOVER
AI030007-C	7" RADIATOR HOSE REMOVER
AB030043	9" DOOR UPHOLSTERY REMOVER
W25	10PCS - DOUBLE OPEN WRENCH: 6X7, 8X9, 10X11,12X13,14X15, 16X17, 18X19, 20X22, 24X27, 30X32MM
H06SA109S	9PCS - ANTI-SLIP EXTRA LONG ARM BALL POINT HEX KEY SET: 1.5, 2, 2.5, 3, 4, 5, 6, 8, 10 MM
H12S110S	10PCS - EXTRAL LONG STAR ARM HEX KEY SET: T9, T10, T15, T20, T25, T27, T30, T40, T45, T50

BALL BEARING SLIDES

C-7DW244V 260PCS PROFESSIONAL MECHANIC TOOL SET W/7-DRAWER TOOL TROLLEY



- Steel thickness: Cabinet-1.0mm drawer, 1.0mm body, 1.2mm top and bottom covers.
- Ball bearing designed for smooth sliding.
- Safe - designed Aluminum end to prevent scratches.
- Internal locking system for extra security.
- One piece steel of Cabinet Body to add more strength.
- 5"x2" Casters
- 200 Lbs loading capacity for each caster

C-7DW1 7-DRAWER TOOL TROLLEY W/KNOCKABLE WORKING TABLE

	W	D	H	
OVERALL	26	18	31-7/8	Inch
	670	460	812	mm
OVERALL (W / CASTERS)	26	18	37-11/16	Inch
	670	460	960	mm
5 DRAWERS	22-5/8	15	2-15/16	Inch
	576	380	75	mm
2 DRAWERS	22-5/8	15	6	Inch
	576	380	154	mm
	N.W	G.W	CUFT	
	74.5KGS	82.5KGS	12.32'	

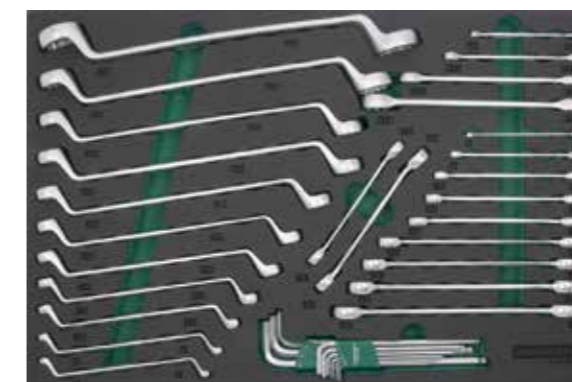

First Drawer

W23135V 35PCS OFFSET RING WRENCH SET

• Contents:

W23	11PCS - 75° OFFSET RING WRENCH, 6x7, 8x9, 10x11, 12x13, 14x15, 16x17, 18x19, 19x21, 19x22, 24x27, 30x32MM
W621	9PCS - DOUBLE RING WRENCH, 06x07, 08x09, 10x11, 12x13, 14x15, 16x17, 18x19, 20x22, 22x24MM
W241	2PCS - FLARE NUT WRENCH, 10x11, 12x14MM
W29	4PCS - STAR WRENCH, E6xE8, E10xE12, 14xE18, E20xE24
H06SA109S	9PCS - ANTI-SLIP EXTRA LONG ARM BALL POINT HEX KEY SET (MM)



- Tray : EVA Form
- Easy to organize for more efficient management
- Provide complete protection for tools

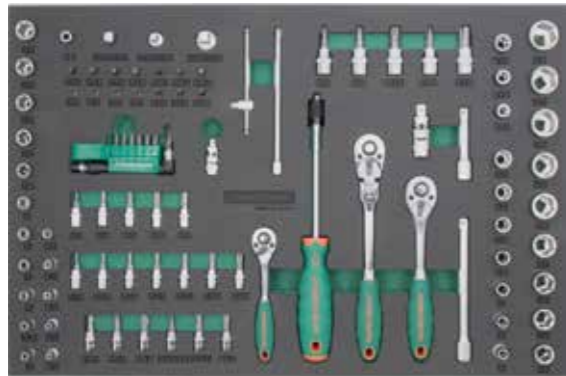

Second Drawer

S04H3194SV 94PCS 1/4", 3/8" & 1/2"DR. SOCKET SET

• Contents:

S04H21	11PCS - 1/4"DR. 6PT FLANK SOCKETS: 5, 5.5, 6, 7, 8, 9, 10, 11, 12, 13, 14MM
S10H2	3PCS - 1/4"DR. SLOTTED BIT SOCKETS: 3.5, 5.5, 7MM
S09H2	5PCS - 1/4"DR. HEX BIT SOCKETS: H3, H4, H5, H6, H7
S11H2	3PCS - 1/4" DR. PHILLIPS BIT SOCKETS: PH1, PH2, PH3
S06H2	5PCS - 1/4"DR. STAR SOCKETS: E4, E5, E6, E7, E8
S07H2	7PCS - 1/4"DR. STAR BIT SOCKETS: T10, T15, T20, T25, T30, T30, T40
S26H2280	1PC - 1/4" SPINNER HANDLE
S23H21115	1PC - 1/4" SLIDING BARS 115MM
S24H2150	1PC - 1/4" ETENSION BARS 150MM
S15H240	1PC - 1/4" UNIVERSAL JOINTS
S44H2206	1PC - 1/4"DR. BIT HOLDER
S08H2ST8S	8PCS - 1/4" DR. BIT SET
D125TT	11PCS - 1/4" HEX SHANK TAMPERPROOF INSERT BITS: T6, T7, T8, T9, T10, T15, T20, T25, T27, T30, T40
S08H355	1PC - 3/8"DR. STAR BIT SOCKET T55 (TAMPERPROOF)
D125P	3PCS - 1/4" HEX SHANK PHILLIPS INSERT BITS: PH1, PH2, PH3
R2902	1PC - 1/4" ANTI SLIP GRIP RATCHET HANDLE-36 TEETH
S16H3814	1PC - ADAPTERS (3/8"x1/4")
S04H31	16PCS - 3/8"DR. 6PT FLANK SOCKETS: 7, 8, 9, 10, 11, 12, 13, 14, 15, 16, 17, 18, 19, 20, 21, 22MM
S06H31	3PCS - 3/8"DR. STAR SOCKETS: E10, E12, E14
S07H340	1PC - 3/8"DR. STAR BIT SOCKETS T40
S64H31	3PCS - 3/8"DR. SPLINE INSERT BIT SOCKET: M6, M8, M10
S24H3	3PCS - 3/8"DR. EXTENSION BARS: 75, 150MML
R2903	1PC - 3/8"DR. ANTI SLIP GRIP RATCHET HANDLE-36 TEETH
R4103	1PC - 3/8"DR. FLEXIBLE RATCHET HANDLE - 36 TEETH
S15H356	1PC - 3/8"DR. UNIVERSAL JOINTS
S16H	2PCS - ADAPTERS: 1/4"(F) x 3/8"(M), 1/2"(F) x 3/8"(M)

Third Drawer

S04H4145V 45PCS 1/2"DR. SOCKET SET

• Contents:

S04H41	17PCS - 1/2"DR. 6PT FLANK SOCKETS: 10, 11, 12, 13, 14, 15, 16, 17, 18, 19, 20, 21, 22, 24, 27, 30, 32MM
S09H43	5PCS - 1/2"DR. HEX BIT SOCKETS: H8, H10, H12, H14, H17
S24H4	3PCS - 1/2"DR. EXTENSION BARS: 50, 130, 250MML
S23H41300	1PC - 1/2"DR. SLIDING BARS 300MM
S15H472	1PC - 1/2"DR. UNIVERSAL JOINT
R2904	1PC - 1/2"DR. ANTI SLIP GRIP RATCHET HANDLE-36 TEETH
S16H3	2PCS - ADAPTERS: 3/8"(F) x 1/2"(M), 3/4"(F) x 1/2"(M)
S03AD43	2PCS - 1/2"DR. 6PT FLANK THIN WALL DEEP IMPACT SOCKETS: 17, 19MM
S06H4	5PCS - 1/2"DR. STAR SOCKETS: E11, E16, E18, E20, E24
S07H4	8PCS - 1/2"DR. STAR BIT SOCKETS: T45, T50, T55, T60 (55MML) T30, T40, T45, T50 (100MML)

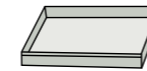
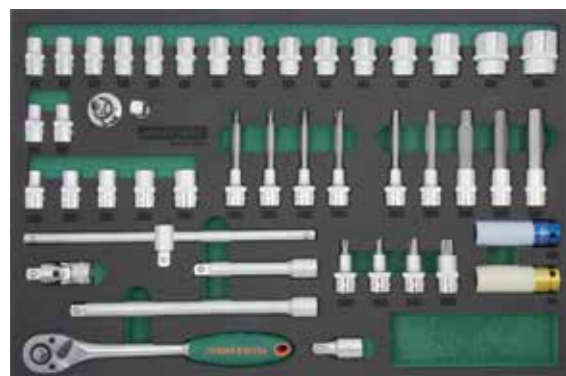

- Tray : EVA Form
- Easy to organize for more efficient management
- Provide complete protection for tools

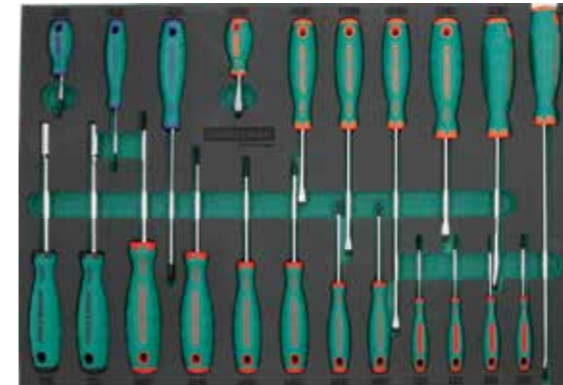

Fourth Drawer

D71P122SV 22PCS ANTI-SLIP GRIP SCREWDRIVER SET

• Contents:

D71T	10PCS - ANTI - SLIP GRIP STAR SCREWDRIVERS: T06, T07, T08, T09, T10, T15, T20, T25, T27, T30
D71S	7PCS - ANTI - SLIP GRIP SCREWDRIVER - SLOTTED: 5.5 x 75, 5.5 x 125, 5.5 x 200, 6.5 x 38, 6.5 x 100, 6.5 x 150, 6.5 x 250MM
D71P	3PCS - ANTI - SLIP GRIP SCREWDRIVER - PHILLIPS: PH0 x 60, PH1 x 38, PH1 x 150MM
D71N	1/4" ANTI - SLIP GRIP NUT DRIVERS: 6, 7MM

Fifth Drawer

P0809SV 9PCS PLIERS SET

• Contents:

P088	8" COMBINATION PLIERS
P118	8" LONG NOSE PLIERS
P32M10A	10" CURVED JAW LOCKING PLIERS WITH WIRE CUTTERS
P2810	10" BOX JOINT PLIERS
P098	8" HEAVY DUTY DIAGONAL CUTTING PLIERS
AG010009	9" (230MM) STRAIGHT NOSE, EXTERNAL PLIERS
AG010012	9" (220MM) BENT NOSE, EXTERNAL PLIERS
AG010003	9" (230MM) STRAIGHT NOSE, INTERNAL PLIERS
AG010006	9" (220MM) BENT NOSE, INTERNAL PLIERS

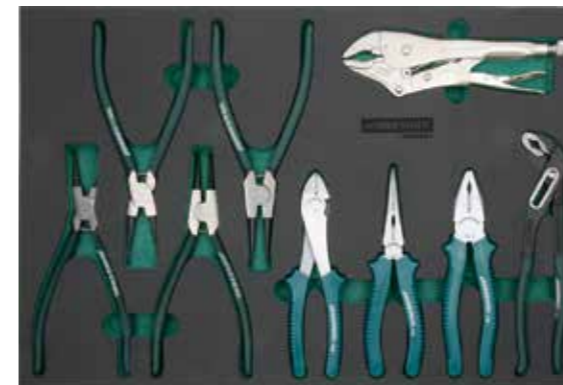

Sixth Drawer

M0917SV 17PCS PUNCH & PRY BAR TOOL SET

• Contents:

M61112	COLD CHISEL 130MM
M60103	CENTER PUNCH 100MM
M63106S	6PCS PIN PUNCH SET: 2x8x115, 3x8x125, 4x9.5x150, 5x9.5x165, 6x12.7x180, 8x12.7x180MM
MF05A	8" FLAT FILE
M07016	SOFT FACE HAMMER
M09500	ENGINEER'S HAMMER 500g
AS-0026	12PCS SPRAY GUN CLEANING KIT
AG010035	3 IN 1 LIGHTED MAGNETIC MIRROR
AI050024	4PCS PRY BAR SET



Seventh Drawer

W25138SV 38PCS COMBINATION & OPEN END WRENCH SET

• Contents:

W25	4PCS - OPEN END WRENCH, SIZE: 16x17, 19x22, 24x27, 30x32mm
W26	19PCS - COMBINATION WRENCH, SIZE: 6, 7, 8, 9, 10, 11, 12, 13, 14, 15, 16, 17, 18, 19, 21, 22, 24, 34, 36mm
H08S110S	10PCS EXTRA LONG ARM STAR TAMPERPROOF KEY SET



BALL BEARING SLIDES



- Steel thickness : Cabinet-1.0mm drawer, 1.0mm body, 1.2mm top and bottom covers.
- Ball-bearing design for smooth sliding.
- Safe-designed Aluminum end to prevent scratches.
- Internal locking system for extra security.
- One piece steel of Cabinet Body to add more strength.
- 5" x 2" Casters
- 200 Lbs loading capacity for each caster



- Tray : EVA Form
- Easy to organize for more efficient management
- Provide complete protection for tools



C-7DW191V 191PCS PROFESSIONAL MECHANICS TOOLS SET W/7-DRAWER TOOL TROLLEY

First Drawer

- **S04H45121SV**
- 81PCS 1/4", 3/8", 1/2" DR. SOCKET SET AND
- 40PCS POWER BIT SET
- CONTENTS:

S29H4140SP	14PCS - 10MM HEX BITS: 30MML: 4, 5, 6, 7, 8, 10, 12 75MML: 4, 5, 6, 7, 8, 10, 12
	14PCS - 10MM STAR BIT: 30MML: T20, T25, T30, T40, T45, T50, T55 75MML: T20, T25, T30, T40, T45, T50, T55
	10PCS - 10MM SPLINE BITS: 30MML: M5, M6, M8, M10, M12 75MML: M5, M6, M8, M10, M12
	2PCS - BIT HOLDERS: 3/8" DR. X 10 MM, 1/2" DR. X 10MM
S04H3457SP	
S04H2	12PCS-1/4" DR. SOCKETS : 4, 4.5, 5, 5.5, 6, 7, 8, 9, 10, 11, 12, 13MM
S04HD2	4PCS-1/4" DR. DEEP SOCKETS : 8, 10, 12, 13MM
	16PCS-1/4" DR. SOCKET BITS : HEX : 3, 4, 5, 6MM, STAR : T10, T20, T25, T27, T30 SLOTTED : 4.5, 5, 7MM PHILLIPS : PH1, PH2, PH3
R3502	1PC-1/4" DR. 72TEETH QUICK RELEASE RATCHET HANDLE
S24H2	2PCS- 1/4" DR. EXTENSION BARS 2" & 6"
S16H302	1PC-ADAPTOR FOR EXTENSION 1/4" (M) X 3/8" (F)
S15H2	1PC-1/4" DR. UNIVERSAL JOINT
S28H1	1PC-1/4" DR. SPINNER HANDLE
S04H3	8PCS- 3/8" DR. SOCKETS : 14, 15, 17, 18, 19, 20, 22, 24MM
S04HD3	3PCS- 3/8" DR. DEEP SOCKETS : 14, 15, 17MM
R3503	1PC-3/8" DR. 72TEETH QUICK RELEASE RATCHET HANDLE
S17H3	2PCS-3/8" DR. SPARK PLUG SOCKETS : 16, 21MM
S15H356	1PC-3/8" DR. UNIVERSAL JOINT
S16H403	1PC-ADAPTOR FOR EXTENSION 3/8" (M) X 1/2" (F)
S24H3	2PCS-3/8" DR. EXTENSION BARS 3" & 10"
S04H4125SP	
S04H4	18PCS-1/2" DR. SOCKETS : 10, 11, 12, 13, 14, 15, 16, 17, 18, 19, 20, 21, 22, 23, 24, 27, 30, 32MM
S17H4	2PCS-1/2" DR. SPARK PLUG SOCKETS : 16 & 21MM
S24H4	2PCS-1/2" DR. EXTENSION BARS : 5" & 10"
S23H4125	1PC-1/2" DR. SLIDING T BAR
S15H472	1PC-1/2" DR. UNIVERSAL JOINT
R3504	1PC-12" DR. 72TEETH QUICK RELEASE RATCHET HANDLE

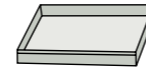

- Tray : EVA Form
- Easy to organize for more efficient management
- Provide complete protection for tools



C-7DW191V 191PCS PROFESSIONAL MECHANICS TOOLS SET W/7-DRAWER TOOL TROLLEY

Second Drawer

- **W60246139SV**
- 39PCS PCS WRENCH SET
- CONTENTS:

W60115S	15PCS 72TEETH REV. RATCHETING COMBINATION WRENCH SET : 8, 10, 11, 12, 13, 14, 15, 16, 17, 18, 19MM
	3PCS ADPTER QUICK RELEASE : 1/4"DR., 3/8"DR., 1/2"DR.
	1PC 10MM BIT HOLDER
W24108SV	8PCS FLARE NUT SET : 8X9, 10X11, 10X12, 13X14, 16X17, 17X19, 22X24, 24X27 MM
W26116S	16PCS COMBINATION WRENCH SET : 6, 7, 8, 9, 10, 11, 12, 13, 14, 15, 16, 17, 18, 19, 22, 24MM
	EVA TRAY

Third Drawer

- **JA-C231SV**
- 1/2" HEAVY DUTY AIR IMPACT WRENCH KIT
- CONTENTS:

JAI-1044	1/2" HEAVY DUTY IMPACT WRENCH
JAR-6309A	1/2" HEAVY DUTY AIR RATCHET WRENCH
JAG-0906RM	6MM HEAVY DUTY MEDIUM AIR DIE GRINDER
S03AD43	3PCS - 1/2" DR. 6PT FLANK THIN WALL IMPACT SOCKETS : 17, 19, 21 MM
S03A4	11PCS - 1/2" DR. 6PT FLANK IMPACT SOCKETS : 10, 11, 12, 13, 14, 16, 17, 19, 21, 22, 24 MM
S03AD4	7PCS - 1/2" DR. 6PT FLANK DEEP IMPACT SOCKETS : 10, 11, 13, 14, 17, 19, 21 MM
S03A3A	1PC - 3/8" F DR. ADAPTOR : 1/2" M
S03A4A	2PCS - 1/2" F DR. ADAPTOR : 3/8" M, 3/4" M
S03A4U	1PC - 1/2" DR. UNIVERSAL JOINT
S03A4E	3PCS - 1/2" DR. EXTENSION BAR : 3", 5", 10"





- Tray : EVA Form
- Easy to organize for more efficient management
- Provide complete protection for tools



AN500001SV 19PCS TIRE REPAIR AND SERVICE TOOL SET

1.	T21340N	1/2"DR. MICROMETER TORQUE WRENCH 60~340NM
2.	AG010206	PULL UP WRENCH, L:435-620MM MAX CAPACITY IS UP TO 500NM
3.	AN010188A	TIRE LEVER WRENCH L:500MM
4.	AN010085A	SNAP IN TIRE VALVE INSTALLER, L:335MM
5.	AN010190	VALVE CORE TORQUE TOOL, TORQUE LIMIT 45NM
6.	AN010191	VALVE CORE TORQUE TOOL, TORQUE LIMIT 25NM
7.	AN010030	WHEEL WEIGHT BALLANCE PLIERS
8.	W26124	COMBINATION WRENCH 24MM
9.	P0917	7" DIAGONAL CUTTING PLIERS (HEAVY DUTY)
10.	AN010269	4PCS-TIRE REPAIR TOOL SET
11.	AI050125-C	25.4MM SUPER SCRAPER, L: 270MM
12.	AG010215	5PCS-REVERSE ACTION WHEEL STUD THREAD RESTORER KIT M12X1.5, M12X1.25, M14X1.5

JONNESWAY



AN500002SV 28PCS WHEEL ALIGNMENT SERVICE TOOL SET

1.	JAI-1044	1/2"DR. HEAVY DUTY IMPACT WRENCH
2.	AE310015N	20PCS-FRONT & REAR HUB INSTALLER REMOVER
3.	W27AS12	12" ADJUSTABLE ANGLE WRENCH
4.	AN010091B	DELUXE INNER TIE ROD TOOL
5.	AN010092	MULTI PURPOSE INNER TIE ROD TOOL
6.	S03AD4	1/2"DR. 6PT FLANK THIN WALL DEEP IMPACT SOCKET: 17, 19, 21MM, 13/16"

JONNESWAY



AN300001SV 13PCS SUSPENSION & UNDERCAR SERVICE TOOL SET

1.	AE320042	3PCS HEAVY DUTY COIL SPRING COMPRESSOR W/JAWS & HOLDER
2.	AN010045	BALL JOINT SEPARATOR OPEN JAW:24MM,L:300MM
3.	AN010046	BALL JOINT SEPARATOR OPEN JAW:17MM,L:405MM
4.	AE310021	OUTER TIE ROD REMOVER
5.	AE310087	UNIVERSAL BALL JOINT SEPARATOR 24MM
6.	AE310115	UNIVERSAL BALL JOINT SEPARATOR 20MM
7.	AI020043	BANDING TOOL WITH CUTTER
8.	R3704	1/2"DR. ANTI-SLIP GRIP RATCHET HANDLE 48 TEETH
9.	S04H4	1/2"DR. 6PT FLANK SOCKETS: 16, 17, 19MM

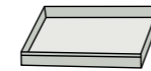

- Tray : EVA Form
- Easy to organize for more efficient management
- Provide complete protection for tools



D71FL20SV 22PCS GO-THRU IMPACT SCREWDRIVER AND FILE SET

1.	JAT-460B	4PCS - LEVER TYPE HAND GREASE GUN W/9" NYLON HOSE & 6" BEND SPOUT
2.	D70S	3PCS - SL8x150, SL6.5x125, SL5.5x100
3.	D70P	3PCS - PH3x150, PH2x100, PH1x75
4.	MF05C	8" HALF ROUND FILE
5.	MFM06S	6PCS - 4" MINI FILE SET
6.	M63106S	6PCS - PIN PUNCH SET: 2x8.0x105, 3x8.0x125, 4x9.5x150, 5x9.5x165, 6x12.7x180, 8x12.7x180 MM

JONNESWAY



P081FL10SV 14PCS PLIERS AND FILE SET

1.	AE310036	5PCS-6" 3-JAWS CR-V GEAR PULLERS
2.	P2712	12" MACHINED TONGUE & GROOVE WATER PUMP PLIERS
3.	P32M10A	10" CURVED JAW LOCKING PLIERS WITH WIRE CUTTERS
4.	AG010002	7"(175mm) STRAIGHT NOSE, INTERNAL PLIERS
5.	AG010005	7"(165mm) BENT NOSE, INTERNAL PLIERS
6.	AG010008	7"(175mm) STRAIGHT NOSE, EXTERNAL PLIERS
7.	AG010011	7"(165mm) BENT NOSE, EXTERNAL PLIERS
8.	P0817	7" COMBINATION PLIERS (EUROPEAN TYPE)
9.	P1118	8" LONG NOSE PLIERS
10.	P0917	7" DIAGONAL CUTTING PLIERS (HEAVY DUTY)

JONNESWAY



S03A4FL14SV 14PCS 1/2"DR. IMPACT SOCKET AND PULLER SET

1.	AE310008	5PCS-INTERNAL & EXTERNAL PULLER SET
2.	S23H6450	3/4"DR. SLIDING BAR L:450MM
3.	M09500	500G ENGINEER'S HAMMER
4.	S03AD6	6PCS-3/4"DR 6PT FLANK DEEP IMPACT SOCKET SET: 18, 19, 22, 24, 27,32MM
5.	MT0302	5m(16ftx3/4") MEASURING TAPES



- Tray : EVA Form
- Easy to organize for more efficient management
- Provide complete protection for tools



W26FL34SV 34PCS COMBINATION WRENCH AND HEX KEY SET

1.	AI050077	25~160MM STRAP WRENCH
2.	AG010034	580MM MAGNETIC PICK-UP TOOL
3.	W26	19PCS-COMBINATION WRENCH, SIZE: 6, 7, 8, 10, 11, 12, 13, 14, 15, 16, 17, 19, 20, 21, 22, 24, 27, 30, 32MM
4.	H03SM109S	9PCS-EXTRA LONG ARM HEX KEY SET, SIZE: 1.5, 2, 2.5, 3, 4, 5, 6, 8, 10MM
5.	H02M1	4PCS-LONG ARM HEX KEY, SIZE: 12,14,17,19MM

JONNESWAY



S04H4FL36SV 40PCS 1/2\"/>

1.	AR020016	5PCS-DIGITAL AUTOMOTIVE ANALYZER & MULTI METER
2.	R2904	1/2\"/>
3.	S22H41375	1/2\"/>
4.	S23H41300	1/2\"/>
5.	S24H4250	1/2\"/>
6.	S24H4125	1/2\"/>
7.	S17H4121	1/2\"/>
8.	S04HD4127	1/2\"/>
9.	S15H472	1/2\"/>
10.	S04H4	18PCS-1/2\"/>
11.	S05A4	8PCS 1/2\"/>
12.	S64H4212	1/2\"/>



C-8DW1162V 217PCS PROFESSIONAL MECHANIC TOOL SET W/8-DRAWER TOOL TROLLEY



First Drawer

P01809SV 9PCS PLIERS SET

• Contents:

P018	8" SIDE CUTTING PLIERS
P038	8" DIAGONAL CUTTER PLIERS
P068	8" LONG NOSE PLIERS
P2010SA	10" AVIATION TIN SNIPS, STRAIGHT CUT
P256	SNAP RING PLIERS
P2712	12" MACHINED TONGUE & GROOVE WATER PUMP PLIERS
P2810	10" BOX JOINT WATER PUMP
P5603	5" SIDE CUTTER PLIERS
P7719	9" WIRE TWISTING PLIERS



Second Drawer

S04H2184SV 74PCS 1/4\"/>

• Contents:

R2802Q	1/4\"/>
S04H2	13PCS-1/4\"/>
S09H2	6PCS-1/4\"/>
S16H3814	ADAPTER: 3/8\"/>
S16H302	ADAPTER FOR SLIDING T-BAR: 1/4\"/>
S15H240	1/4\"/>
S24H2	2PCS-1/4\"/>
S22H21150	1/4\"/>
S23H21130	1/4\"/>
S26H2150	1/4\"/>
S26H2280	1/4\"/>
S27H2	1/4\"/>
S41H216	1/4\"/>
DBT31B	31PCS-SCREWDRIVER BIT SET PHILLIPS: PH1, 2, 3 SLOTTED: 4x0.8, 5.5x1, 6.5x1.2 POZIDRIV: 2PCS-PZ1, 2, 3 HEXAGON: 4, 5, 6MM STAR: 2PCS-T10, T20, T40, 3PCS-T15, T25, T30 QUICK RELEASE BIT HOLDER L: 51MM
D3765P08S	8PCS-PRECISION SCREWDRIVER SET 5PCS SLOTTED: 2, 2.4, 3, 3.5, 4.0MM 3PCS-PHILLIPS: 00, 0, 1
D70S	2PCS - GO THRU IMPACT SCREWDRIVER: SL#9.5x200, SL#9.5x300
D71SA5150	ANTI-SLIP GRIP SCREWDRIVER: SLOTTED 5x150
DV13S5125	1000V INSULATED SCREWDRIVER: 5.5X125MM



- Tray : EVA Form
- Easy to organize for more efficient management
- Provide complete protection for tools



- Tray : EVA Form
- Easy to organize for more efficient management
- Provide complete protection for tools

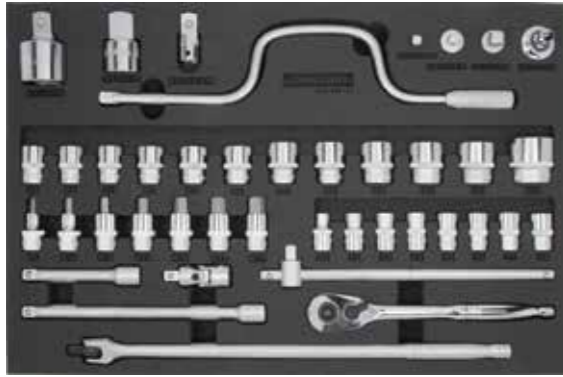

Third Drawer

S04H4941SV 41PCS 1/2"DR. SOCKET WRENCH SET

• Contents:

R2804Q	1/2" DR. RATCHET HANDLE-48 TEETH
S05H4	20PCS- 1/2"DR. 12PT SOCKETS: 10, 12, 13, 14, 15, 16, 17, 18, 19, 20, 21, 22, 23, 24, 25, 26, 27, 28, 30, 36MM
S09H4	7PCS-1/2"DR. HEX BIT SOCKETS: H8, H10, H12, H14, H16, H17, H19
S15H472	1/2" DR. UNIVERSAL JOINT
S16H1034	ADAPTER: 1"(F) x 3/4"(M)
S16H1234	ADAPTER: 1/2"(F) x 3/4"(M)
S16H1438	ADAPTER: 1/4"(F) x 3/8"(M)
S16H304	ADAPTER FOR SLIDING T-BAR:1/2"(M) x 3/8"(F)
S16H3410	ADAPTER: 3/4"(F) x 1"(M)
S16H3412	ADAPTER: 3/4"(F) x 1/2"(M)
S16H403	ADAPTER FOR SLIDING T-BAR: 3/8"(M) X 1/2"(F)
S22H41450	1/2"DR. FLEXIBLE HANDLE, L: 450MM
S24H4	2PCS - 1/2"DR. EXTENSION BAR, L: 125 & 250MM
S23H41300	1/2"DR. SLIDING T BAR, L:300MM
S41H41	1/2"DR. SPEED HANDLE, L: 16-1/4"(412MM)

Fourth Drawer

R19H3126SV 26PCS 3/8"DR. CROWFOOT WRENCH SET

• Contents:

AG010033	TELESCOPING INSPECTION MIRROR, SIZE: 50 X 92 MM
AG010034	MAGNETIC PICK-UP TOOL, CAPACITY: 3.5 LBS
H06S109S	9PCS EXTRA LONG BALL POINT HEX KEY SET, SIZE: 1.5, 2, 2.5, 3, 4, 5, 6, 8, 10 MM
AI050057	OIL FILTER WRENCH
AI060020	BLADES METRIC GAUGE: 0.05, 0.10, 0.15, 0.20, 0.25, 0.30, 0.35, 0.40, 0.45, 0.50, 0.55, 0.60, 0.65, 0.70, 0.75, 0.80, 0.85, 0.90, 0.95, 1.00MM
AI030022-3	STRAIGHT PICK TOOL
R19H310S	10PCS 3/8"DR. CROWFOOT WRENCH
P2208A	8" STRAIGHT PATTERN SNIPS
MK2040	UTILITY KNIFE

Fifth Drawer

MF0516SV 20PCS FILE TOOL SET

• Contents:

MF05S	5PCS - FILE SET, L: 8"
MF17A	FLAT FILE, L: 160MM
MF17B	HALF ROUND FILE, L: 160MM
MF17C	TRIANGULAR FILE, L: 160MM
MF17D	SQUARE FILE, L: 160MM
MF17E	ROUND FILE, L: 160MM
MF17F	FLAT-POINT FILE, L: 160MM
MF17G	KNIFE TEPY FILE, L: 160MM
MF17H	BARRETTE FILE, L: 160MM
MF17J	CROSSING FILE, L: 160MM
F17K	OVAL FILE, L: 160MM
MF17L	FEATHER EDGE FILE, L: 160MM
MF17M	ROUND EDGE FLAT FILE, L: 160MM
MT0703	MEASURING TAPE 8MX25MM
MTC156	STAINLESS STEEL RULER: 12"(300MM)
V1501	HEAVY DUTY EASY STRIPPER, L: 205MM

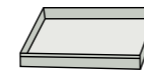

- Tray : EVA Form
- Easy to organize for more efficient management
- Provide complete protection for tools



Sixth Drawer

W24113SV 13PCS FLARE NUT WRENCH TOOL SET

• Contents:

M04008	BALL PEEN HAMMER: 8 OZ
M60104	CENTER PUNCH, SIZE: 4
M63102	PIN PUNCH, SIZE: 2X30
M63105	PIN PUNCH, SIZE: 5X55
M63106	PIN PUNCH, SIZE: 6X55
MHS100AG	HEAVY DUTY DELUXE TYPE HACKSAW W/ 12" H.S.S. BLADE
W24	6PCS-FLARE NUT WRENCH: 9x11,10x12,13x14,16x17, 18x19, 21x23MM
W53119	MIDGET COMBINATION WRENCH, SIZE: 19MM

Seventh Drawer

W26126SV 26PCS COMBINATION WRENCH SET

• Contents:

W261	26PCS-COMBINATION WRENCH: 6, 7, 8, 9, 10, 11, 12, 13, 14, 15, 16, 17, 18, 19, 20, 21, 22, 23, 24, 25, 26, 27, 28, 29, 30, 32MM
------	--



Eighth Drawer

W26008SV 8PCS COMBINATION WRENCH SET

• Contents:

W26	7PCS-COMBINATION WRENCH: 34, 35, 36, 38, 41, 46, 50MM
AG010038A	PROFESSIONAL 3 FUNCTION TIRE GAUGE, L : 375MM





ONE-DRAWER OPEN SYSTEM

creates a safety operating condition to users.

- Steel Thickness : Cabinet-1.0mm. Drawer & Body-1.0mm.
- Top & Bottom Cover-1.2mm
- Ball Bearing design for smooth sliding.
- Ergonomic End of Drawer.
- Internal Locking System for extra security.
- One Piece Steel of Cabinet Body. 5" X 2" Casters.
- 200 Lbs loading capacity for each caster.

JONNESWAY

C-7DW9 7-DRAWER TOOL TROLLEY W/KNOCKABLE WORKING TABLE

ITEM NO.	W	D	H	
OVERALL	26.3	18	32	Inch
	670	460	812	mm
OVERALL (W/CASTERS)	26	18	37.7	Inch
	670	460	960	mm
5 DRAWERS	22	15	2.9	Inch
	576	380	75	mm
2 DRAWERS	22.8	15	6	Inch
	576	380	154	mm
	N.W	G.W	CUFT	
	74.5 KGS	82.5 KGS	12.32'	

ONE-DRAWER OPEN SYSTEM



JONNESWAY

C-7DW7 7-DRAWER TOOL TROLLEY W/WORKING TABLE

ITEM NO.	W	D	H	
OVERALL	26.3	18	32	Inch
	670	460	812	mm
OVERALL (W/CASTERS)	26	18	37.7	Inch
	670	460	960	mm
5 DRAWERS	22.8	15	2.9	Inch
	576	380	75	mm
2 DRAWERS	22.8	15	6	Inch
	576	380	154	mm
	N.W	G.W	CUFT	
	74.5 KGS	82.5 KGS	12.32'	

BALL BEARING SLIDES



C-5DW1 5-DRAWER TOOL TROLLEY W/KNOCKABLE WORKING TABLE

	W	D	H	
OVERALL	26.3"	18"	25.5"	Inch
	670	460	656	mm
OVERALL (W / CASTERS)	26.3"	18"	31.3"	Inch
	670	460	795	mm
3 DRAWERS	22.8"	15"	2.2"	Inch
	579	380	56	mm
2 DRAWERS	22.8	15"	4.8"	Inch
	579	380	123	mm
	N.W.	G.W.	CUFT	
	61KGS	68KGS	10.22"	

- Steel thickness : Cabinet-1.0mm drawer,1.0mm body, 1.2mm top and bottom covers.
- Ball-bearing design for smooth sliding.
- Safe-designed Aluminum end to prevent scratches.
- Internal locking system for extra security.
- One piece steel of Cabinet Body to add more strength.
- 5" Casters
- 200 Lbs loading capacity for each caster

BALL BEARING SLIDES



JONNESWAY

C-7DW1 7-DRAWER TOOL TROLLEY W/KNOCKABLE WORKING TABLE

	W	D	H	
OVERALL	26.3"	18"	32"	Inch
	670	460	813	mm
OVERALL (W / CASTERS)	26.3"	18"	37"	Inch
	670	460	943	mm
5 DRAWERS	22.8"	15"	2.2"	Inch
	579	380	56	mm
2 DRAWERS	22.8	15"	4.8"	Inch
	579	380	123	mm
	N.W.	G.W.	CUFT	
	74.5KGS	82.5KGS	12.32"	

- Steel thickness : Cabinet-1.0mm drawer,1.0mm body, 1.2mm top and bottom covers.
- Ball-bearing design for smooth sliding.
- Safe-designed Aluminum end to prevent scratches.
- Internal locking system for extra security.
- One piece steel of Cabinet Body to add more strength.
- 5" x 2" Casters
- 200 Lbs loading capacity for each caster



JONNESWAY

C-7DW5 7-DRAWER TOOL TROLLEY W/WORKING TABLE

	W	D	H	
OVERALL	26.3"	18"	32"	Inch
	670	460	813	mm
OVERALL (W / CASTERS)	26.3"	18"	37"	Inch
	670	460	943	mm
5 DRAWERS	22.8"	15"	2.2"	Inch
	579	380	56	mm
2 DRAWERS	22.8	15"	4.8"	Inch
	579	380	123	mm
	N.W.	G.W.	CUFT	
	74.5KGS	82.5KGS	12.32'	

C-7DWB53 53" 7-DRAWER ROLL-WAGON

- FULLY SHELF-CLOSING, BALL BEARING SLIDES
- ONE DRAWER OPEN AT A TIME LOCKING SYSTEM

ITEM NO.	W	D	H	
OVERALL	53	18	38 5/8	Inch
	1358	460	980	mm
OVERALL (W/CASTERS)	53	18	45 1/2	Inch
	1358	460	1150	mm
5 DRAWERS	47 7/8	15	3 15/16	Inch
	1215	380	100	mm
2 DRAWERS	47 7/8	15	6	Inch
	1215	380	153	mm
	N.W	G.W	CUFT	
	140 KGS	150KGS	30.5'	



BALL BEARING SLIDES



KNOCKABLE WORKING TABLE

C-7DW136	136 PCS PROFESSIONAL MECHANICS TOOLS SET W/7-DRAWER TOOL TROLLEY
W/KNOCKABLE WORKING TABLE W/TOOL HOLDER	

JONNESWAY

BALL BEARING SLIDES



KNOCKABLE WORKING TABLE

C-5DW108	112 PCS PROFESSIONAL MECHANICS TOOLS SET W/5-DRAWER TOOL TROLLEY
W/KNOCKABLE WORKING TABLE W/TOOL HOLDER	

JONNESWAY



1ST DRAWER

W23108SP	H10MB08SP
W26116SP	W26116SP

W23108SP	8 PCS 75° OFFSET RING WRENCH SET
SIZE : 6X7, 8X9, 10X11, 12X13, 14X15, 16X17, 18X19, 20X22mm	

W26116SP	16 PCS COMBINATION WRENCH SET
SIZE : 6, 7, 8, 9, 10, 11, 12, 13, 14, 15, 16, 17, 18, 19, 22, 24mm	

H10MB08SP	8 PCS POWER HANDLE TWO WAY BALL POINT AND HEX KEY SET
SIZE : 2x135x75mm, 2.5x135x75mm, 3x135x75mm, 4x192x95mm, 5x192x95mm, 6x192x95mm, 8x240x110mm, 10x240x110mm	

JONNESWAY



2ND DRAWER

P0803SP	S04H4125SP
	S04H3157SP

P0803SP	3 PCS PLIERS SET
7" COMBINATION PLIER 7" HEAVY DUTY DIAGONAL CUTTING PLIER 8" LONG NOSE PLIER	

S04H4125SP	25 PCS 1/2" DR. SOCKET WRENCH SET
-------------------	--

S04H3157SP	56 PCS 1/4" & 3/8" DR. SOCKET WRENCH SET
-------------------	---

JONNESWAY



3RD DRAWER

P2803SP	D04PP08SP	AG010026SP	AG010002SP
----------------	------------------	-------------------	-------------------

P2803SP	3 PCS 10" PLIER AND ADJUSTABLE WRENCH SET
----------------	--

D04PP08SP	8 PCS FULL STAR SCREWDRIVER SET
------------------	--

AG010026SP	5 PCS HAMMER & CHISEL SET
-------------------	--------------------------------------

AG010002SP	4 PCS INTERNAL & EXTERNAL PLIER SET
-------------------	--



1ST DRAWER

AG010026SP	P018SP	P2710SP	W45112SP
-------------------	---------------	----------------	-----------------

JONNESWAY

AG010026SP	5 PCS HAMMER & CHISEL SET
-------------------	--------------------------------------

P018SP	3 PCS PLIERS SET
8" SIDE CUTTING PLIER 8" DIAGONAL CUTTER PLIERS 8" LONG NOSE PLIER	

P2710SP	2PCS PLIERS SET
10" MACHINED TONGUE & GROOVE WATER PUMP PLIER 10" CURVED JAWS LOCKING PLIER WITH WIRE CUTTER	

W45112SP	12PCS 72 TEETH RATCHETING COMBINATION WRENCH
SIZE : 10, 11, 12, 13, 14, 15, 16, 17, 18, 19, 21, 22mm	



2ND DRAWER

D04PP08SP	S04H4125SP
	S04H3157SP

D04PP08SP	8 PCS FULL STAR SCREWDRIVER SET
------------------	--

S04H4125SP	25 PCS 1/2" DR. 6PT FLANK SOCKET WRENCH SET
SIZE : 10-32mm	

S04H3157SP	56PCS 1/4" & 3/8" DR. 6PT FLANK SOCKET WRENCH SET
-------------------	--



- Tray : EVA Form
- Easy to organize for more efficient management
- Provide complete protection for tools

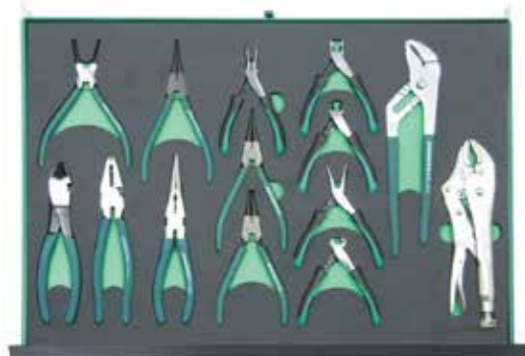

P82714SV 14PCS PLIERS SET

CONTENTS:

P018S	8" SIDE CUTTING PLIERS & 8" DIAGONAL PLIERS & 8" LONG NOSE PLIERS
P7105S	5PCS MINIATURE PLIERS
P7101	140MM MINIATURE BENT NEEDLE NOSE PLIERS
P7102	110MM H.D. MINIATURE END CUTTING NIPPER
P7103	115MM H.D. MINIATURE DIAGONAL PLIERS
P7104	120MM H.D. MINIATURE LINESMAN PLIERS
P7105	135MM H.D. MINIATURE LONG NOSE PLIERS
AG010002S	4PCS INTERNAL & EXTERNAL PLIERS SET
P2710S	10" MACHINED TONGUE & GROOVE WATER PUMP PLIERS + 10" CURVED JAW PLIERS
	EVA TRAY

JONNESWAY



D737134SV 34PCS SCREWDRIVER, DOUBLE FLEX. SOCKET AND PRECISION SD SET

CONTENTS:

D376514LS	14PCS PRECISION SCREWDRIVER SET : ⊕ PH#1, PH#0, PH#00, ⊖ 3.0, 2.4, 2.0, ⊕ T20, T15, T10, T9, T8, T7, T6, T5
W43A107S	7PCS DOUBLE FLEXIBLE SOCKET SET : 6X7, 8X9, 10X11, 12X13, 14X15, 16X17, 18X19MM
D70105S	GO-THROUGH SCREWDRIVER SET 3PCS SLOTTED: 6.5X125MM, 8X150MM, 9.5X175MM 2PCS PHILLIPS: #2X100MM, #3X150MM
D71PP08S	ANTI-SLIP GRIP SCREWDRIVER SET 4PCS SLOTTED : 6.5X38, 4X80, 5.5X125, 6.5X150 4PCS PHILLIPS : PH2X38, PH1X80, PH2X100, PH3X150
	EVA TRAY

JONNESWAY



H10121SV 16PCS TWO WAY HEX KEY SET AND 5PCS HAMMER CHISEL SET

CONTENTS:

H10MB08S	8PCS TWO WAY BALL POINT HEX KEY SET, 8660 : 2X100, 2.5X100, 3X100, 4X100, 5X150, 6X150, 8X200, 10X200MM
H10MT08S	8PCS TWO WAY STAR TAMPERPROOF KEY SET, 8660 : T10X100, T15X100, T20X100, T25X100, T27X150, T30X150, T45X200, T50X200
AG010026S	5PCS HAMMER CHISEL SET, 1PC 300G ENGINE HAMMER 1PC HEAD DIA 35MM DEAD BLOW HAMMER, 3PCS COLD CHISEL SET
	EVA TRAY



- Tray : EVA Form
- Easy to organize for more efficient management
- Provide complete protection for tools



AE300002SV 58PCS LUG NUT REMOVAL TOOL SET

1.	AN010257	2PCS-SLIDING HAMMER LOCKING PLIERS
2.	AG010212	STUD REMOVER 1/4"-3/4"
3.	AG010055A	7PCS-IMPACT DRIVER SET
4.	AG010061	7PCS-STUD PULLER WRENCH SET: 5, 6, 7, 8, 10, 12, 14MM
5.	AG010208	8PCS-TORX PLUS EXTRATOR SET: 3, 4, 5, 6, 7, 8, 10, 12MM
6.	AG010213	15PCS-1/4" & 1/2"DR. LUG NUT REMOVAL SOCKET SET 1/4"DR. SOCKETS: 6, 8, 10, 11, 12MM 1/2"DR. SOCKETS: 13, 14, 15, 17, 19, 21, 24, 27MM STRAIGHT RODS: Ø6XØ8X(L)74MM, Ø7XØ12X(L)80MM
7.	AG010214	4PCS-1/2"DR. LUG NUT TWISTED REMOVAL SOCKET SET 1/2"DR. SOCKETS: 17, 19, 21MMX(L)145MM STRAIGHT RODS: Ø12X(L)155MM
8.	AG010215	5PCS-REVERSE ACTION WHEELS STUD THREAD RESTORER SET: M12X1.25, M12X1.5, M14X1.5, O-RINGX2PCS
9.	AG010216	9PCS-AXLE SPINDLE RETHREADING SET, SIZE: M24X2.0, M24X1.5, M22X1.5, M22X1.0, M20X1.5, M20X1.25, 3/4"-20, 13/16"-20

JONNESWAY



AI100006SV 30PCS ENGINE SERVICE TOOL SET

1.	AI050049	CHAIN WRENCH (L: 30~160MM)
2.	AI050008-10	10" ADJUSTABLE OIL FILTER WRENCH 50~85MM
3.	AI050002	OIL FILTER WRENCH 3-LEG, 2-WAY, 65~120MM(2-1/2"~4")
4.	AI050043S	3PCS STAINLESS STEEL SCRAPER KNIFE SET
5.	AI050043	OIL FILTER MASTER PLIERS 53~118MM (2-1/8"~4-5/8")
6.	AI050191	MAGNETIC OIL DRAIN PLIERS
7.	AG010034	MAGNETIC PICK-UP TOOL, L:580MM
8.	AI030022	4PCS MINI HOOK & PICK SET
9.	AI030002A	15PCS DRAIN KEY & T-BAR SET
10.	P6008	8" SLIP JOINT PLIERS
11.	D70S9175	GO-THRU IMPACT SCREWDRIVER: SL9.5X175



MODEL : A



W23108SP 8 PCS 75° OFFSET RING WRENCH SET

CONTENTS:

W23	6x7,8x9, 10x11, 12x13, 14x15, 16x17, 18x19, 20x22MM
-----	---

JONNESWAY



W03112SP 12PCS NON-SLIP CLOSE END AND FAST OPERATING WRENCH SET

CONTENTS:

W03	10, 11, 12, 13, 14, 15, 16, 17, 18, 19, 21, 22MM
-----	--

JONNESWAY



W45112SP 12PCS 72 TEETH RATCHETING COMBINATION WRENCH SET

CONTENTS:

W45	8, 9, 10, 11, 12, 13, 14, 15, 16, 17, 18, 19MM
-----	--

JONNESWAY



W45308SP 8PCS 72 TEETH RATCHETING COMBINATION WRENCH SET

CONTENTS:

W45	8, 10, 11, 12, 13, 14, 17, 19MM
-----	---------------------------------

JONNESWAY



W47108SP 8PCS BOX WRENCH SET

CONTENTS:

W471	6x7, 8x9, 10x11, 12x13, 14x15, 16x18, 17x19, 21X22MM
------	--

JONNESWAY



W47708SP 8PCS BOX WRENCH SET

CONTENTS:

W477	6x7, 8x9, 10x11, 12x13, 14x15, 16x18, 17x19, 21X22MM
------	--

JONNESWAY



S04H4317SP 17PCS 1/2"DR. SOCKET SET

CONTENTS:

S04H4	13PCS-1/2" DR. 6PT FLANK SOCKETS : 8, 10, 12, 13, 14, 17, 19, 21, 22, 23, 24, 26, 32MM
S15H472	1PC-UNIVERSAL JOINT
S17M4	2PCS-MAGNETIC SPARK PLUG SOCKETS : 16, 21MM
R2904	1PC-1/2" DR. QUICK RELEASE RATCHET HANDLE-36 TEETH



MODEL : A



S04H2125SP 24PCS 1/4"DR. SOCKET SET

CONTENTS:

S04H2	11PCS - 1/4" DR. SOCKETS: 4,5,5.5,6,7,8,9,10,11,12,13MM
S04HD2	9PCS - 1/4" DR. DEEP SOCKETS: 5,6,7,8,9,10,11,12,13MM
R3702	1PC - 1/4" DR. RATCHET HANDLE - 48TEETH
S24H2	2PCS - 1/4" DR. EXTENSION BARS: 2" & 6"
S46H2	1PC - SPINNER HANDLE

JONNESWAY



P60105SP 5PCS MECHANIC TOOLS SET

CONTENTS:

S23H41300	1PC-1/2" DR. SLIDING T-BAR, L : 300MM
S24H4	2PCS-1/2" DR. EXTENSION BAR, L : 125, 250MM
A1060020	1PC-FEELER GAUGES 20 BLADES
P6008	1PC-8" SLIP JOINT PLIERS

JONNESWAY



S06H427SP 27PCS 1/2"DR. & 3/8"DR. BIT SOCKET SET

CONTENTS:

S09H4	11PCS - 1/2"DR. HEX BIT SOCKET
S49H4	10PCS - 1/2"DR. SPLINE BIT SOCKET
S09H3	6PCS - 3/8"DR. HEX BIT SOCKET

JONNESWAY



S07H4118SP 18PCS 1/2"DR. STAR BIT SOCKET SET

CONTENTS:

9PCS-55MML	T20, T25, T27, T30, T40, T45, T50, T55, T60
9PCS-100MML	T20, T25, T27, T30, T40, T45, T50, T55, T60

JONNESWAY



S09H4118SP 18PCS 1/2"DR. HEX BIT SOCKET SET

CONTENTS:

9PCS-55MML	H5, H6, H7, H8, H10, H12, H14, H17, H19MM
9PCS-100MML	H5, H6, H7, H8, H10, H12, H14, H17, H19MM



MODEL : A



S29H4140SP 40PCS 3/8" & 1/2" DR. POWER BIT SET

CONTENTS:

14PCS - 10MM HEX BITS: 30MML: 4, 5, 6, 7, 8, 10, 12 75MML: 4, 5, 6, 7, 8, 10, 12
14pcs - 10MM STAR BIT: 30MML: T20, T25, T30, T40, T45, T50, T55 75MML: T20, T25, T30, T40, T45, T50, T55
10pcs - 10MM SPLINE BITS: 30MML: M5, M6, M8, M10, M12 75MML: M5, M6, M8, M10, M12
2pcs - BIT HOLDERS: 3/8" Dr. X 10 MM, 1/2" Dr. X 10MM

JONNESWAY



W43A107SP 7PCS DOUBLE FLEXIBLE SOCKET WRENCH SET

CONTENTS:

W43A 6x7, 8x9, 10x11, 12x13, 14x15, 16x17, 18x19MM
--

JONNESWAY



S03A401SP 7PCS 1/2" DR. IMPACT SOCKET ACCESSORY SET

CONTENTS:

S03A3A4	1PC - ADAPTOR 3/8"F X 1/2"M
S03A4A	2PCS - ADAPTOR 1/2"F X 3/8"M, 1/2"F X 3/4"M
S03A4U4	1PC - 1/2" DR. UNIVERSAL JOINT
S03A4E	3PCS - 1/2" DR. EXTENSION BAR, LENGTH: 3", 5", 10"

JONNESWAY



S03A4122SP 22PCS 1/2" DR. 6PT FLANK IMPACT SOCKET SET (MM)

CONTENTS:

S03A41	11PCS - 1/2" DR. 6PT FLANK IMPACT SOCKETS: 10, 11, 12, 13, 14, 16, 17, 19, 21, 22, 24 MM
S03AD41	11PCS - 1/2" DR. 6PT FLANK DEEP IMPACT SOCKETS: 10, 11, 12, 13, 14, 16, 17, 19, 21, 22, 24 MM

JONNESWAY



S03A4222SP 22PCS 1/2" DR. 6PT FLANK IMPACT SOCKET SET (SAE)

CONTENTS:

S03A42	11PCS - 1/2" DR. 6PT FLANK IMPACT SOCKETS: 3/8", 7/16", 1/2", 9/16", 5/8", 11/16", 3/4", 13/16", 7/8", 15/16", 1"
S03AD42	11PCS - 1/2" DR. 6PT FLANK DEEP IMPACT SOCKETS: 3/8", 7/16", 1/2", 9/16", 5/8", 11/16", 3/4", 13/16", 7/8", 15/16", 1"



MODEL : A



P0803SP 3 PCS PLIERS SET

CONTENTS:

P087	7" COMBINATION PLIERS
P097	7" HEAVY DUTY DIAGONAL CUTTING PLIERS
P118	8" LONG NOSE PLIERS

JONNESWAY



P018SP1 PLIERS & HEX KEY SET

CONTENTS:

P018	1PC-8" SIDE CUTTING PLIERS
P038	1PC-8" DIAGONAL CUTTER PLIERS
P068	1PC-8" LONG NOSE PLIERS
H01SM109S	1SET-HEX KEY

JONNESWAY



P018SP PROFESSIONAL PLIERS SET

CONTENTS:

P018	1PC-8" SIDE CUTTING PLIERS
P038	1PC-8" DIAGONAL CUTTER PLIERS
P068	1PC-8" LONG NOSE PLIERS

JONNESWAY



P2803SP 3PCS PLIERS AND ADJUSTABLE WRENCH SET

CONTENTS:

W27AS10	1PC-10" ADJUSTABLE WRENCH
P2810	1PC-10" BOX JOINT PLIERS
P32M10A	1PC-10" CURVED JAW LOCKING PLIERS

JONNESWAY



P2710SP PLIERS SET

CONTENTS:

P2710	1PC-10" MACHINED TONGUE & GROOVE WATER PUMP PLIERS
P32M10A	1PC-10" CURVED JAWS LOCKING PLIERS WITH WIRE CUTTER

JONNESWAY



AG010002SP 4PCS INTERNAL & EXTERNAL PLIERS SET

CONTENTS:

AG010002	1PC-7"(175MM) STRAIGHT NOSE, INTERNAL PLIERS
AG010005	1PC-7"(175MM) BENT NOSE, INTERNAL PLIERS
AG010008	1PC-7"(175MM) STRAIGHT NOSE, EXTERNAL PLIERS
AG010011	1PC-7"(175MM) BENT NOSE EXTERNAL PLIERS



MODEL : A



M08503SP 3PCS HAMMER & WOOD CHISEL SET

CONTENTS:

M04016	1PC-16OZ BALL PEEN HAMMER W/FIBERGLASS HANDLE
M11045	1PC-HEAD DIA 45MM DEAD BLOW HAMMER
M65225	1PC-1" WOOD CHISEL W/ACETATE HANDLE

JONNESWAY



AG010026SP 5PCS HAMMER & CHISEL SET

CONTENTS:

M09300	1PC-300G ENGING HAMMER
M11035	1PC-HEAD DIA 35MM DEAD BLOW HAMMER
M61	3PCS COLD CHISEL SET

JONNESWAY



M09513SP 13PCS HAMMER & PUNCH-CHISEL SET

CONTENTS:

M07016	1PC - 16 OZ SOFT FACE HAMMER
M09500	1PC - 500G DIN ENGINEER HAMMER
M63M106S	6PCS - PIN PUNCH SET (MIRROR POLISH)
M64M105S	5PCS - PUNCH & CHISEL SET (MIRROR POLISH)

JONNESWAY



D71PP08SP 8PCS ANTI-SLIP SCREWDRIVERS SET

CONTENTS:

D71S	4PCS - SLOTTED SCREWDRIVERS: 6.5X38, 4X80, 5.5X125, 6.5X150
D71P	4PCS - PHILLIPS SCREWDRIVERS: #2X38, #1X80, #2X100, #3X150

JONNESWAY



D04PP08SP 8PCS FULL STAR SCREWDRIVER SET

CONTENTS:

D04S	4PCS-SLOTTED SCREWDRIVERS : 6.5x38, 4x80, 5.5x125, 6.5x150
D04P	4PCS-PHILLIPS SCREWDRIVERS : #2x38, #1x80, #2x100, #3x150

JONNESWAY



D70105SP 5PCS GO-THROUGH IMPACT SCREWDRIVER SET

CONTENTS:

D70S	3PCS - SLOTTED SCREWDRIVERS: 6.5X125, 8X150, 9.5X175
D70P	2PCS - PHILLIPS SCREWDRIVERS: #2X100, #3X150



MODEL : A



AB10001SP WINDSHIELD REPAIR KIT

CONTENTS:

Seq.	ITEM NO.	DESCRIPTION
1.	AB010029	WINDSHIELD REMOVAL KIT
2.	AB010017	QUICK RELEASE W/O CUT OUT TOOL

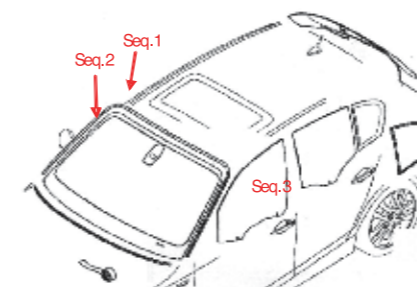

JONNESWAY

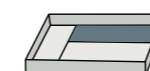

AG010150SP SNAP RING PLIER SET

CONTENTS:

ITEM NO.	A (LENGTH)	B (ANGLE)	C (TIP SIZE)
AG010150H	9"	0°	.090" (2.3 MM)
AG010150G	8-1/2"	70°	.090" (2.3 MM)
AG010150F	8"	0°	.070" (1.8 MM)
AG010150E	7-1/2"	70°	.070" (1.8 MM)
AG010150D	6"	0°	.047" (1.2 MM)
AG010150C	5-1/2"	70°	.047" (1.2 MM)
AG010150B	6"	0°	.038" (1.0 MM)
AG010150A	5-1/2"	70°	.038" (1.0 MM)
HOOK TOOL	5"	0°	
PICK TOOL	5"	70°	

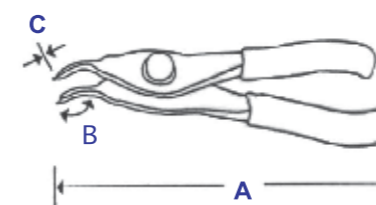

JONNESWAY

- For Internal or External Snap Rings
- Thumbscrew Permits Quick Conversion

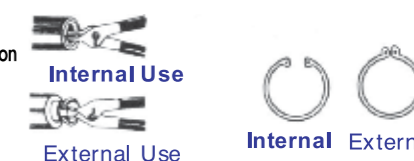

AG10001SP 40PCS TAP & DIE SET(MM)

34PCS- TAP AND DIE
M3X0.5, M3X0.6, M4X0.7, M4X0.75, M5X0.8, M5X0.9, M6X0.75
M6X1.0, M7X0.75, M7X1.0, M8X1.0, M8X1.25
M10X1.25, M10X1.5, M12X1.5, M12X1.75, 1/8NPT27
1PC - TAP WRENCH M4-M12
1PC - "T" TYPE TAP WRENCH
1PC - DIE STOCK 25MM
1PC - AUTO CENTER PUNCH
1PC - SCREW PITCH GAUGE
1PC - BRUSH





AI10002SP BELT DRIVER PULLEY PULLER SET

CONTENTS:

AE310030	4" 2 Jaw CR-V Gear Puller
AE310035-1	4" 3 Jaw CR-V Gear Puller
AN010038	Seal Puller
AI020087A	Crankshaft Drive Belt Pulley Puller

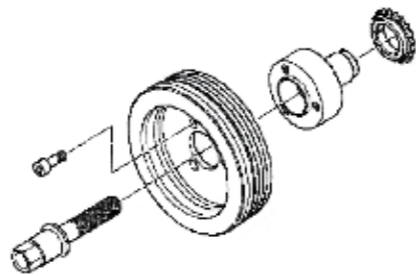
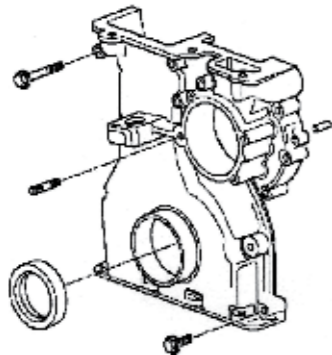

AI10001SP VALVE TIMING INSTALLER/REMOVER TOOL KIT

• Ideal For The Replacement Of Valve Stem Seals Without Removing The Cylinder Head.

CONTENTS:

ITEM NO.	DESCRIPTION
AN010064	OVERHEAD VALVE SPRING COMPRESSOR
AI020056	VALVE STEM SEAL PLIERS
AI020099	HAND MOLDING VALVE SPRING COMPRESSOR
AI020100	VALVE HOLDER
AI010012A	VALVE COLLETS REPLACER

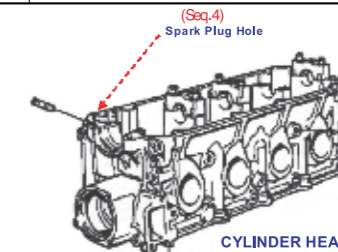
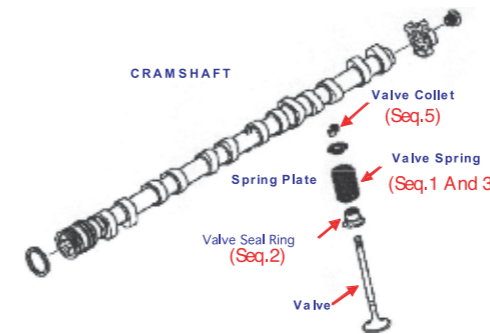

JONNESWAY

JONNESWAY

JONNESWAY



AI10003SP ENGINE SERVICE KIT

CONTENTS:

AI050004T	9PCS - OIL FILTER CAP WRENCH
AI030002A	15PCS - DRAIN KEY & T-BAR SET
AI050049	30-160 MM OIL FILTER CHAIN WRENCH

DESCRIPTION	
8MM	BMW, FORD
9MM	GENERAL MOTOR
10MM	FORD
12MM	FIAT LANCIA, PEUGEOT
14MM	MERCEDES, LANCIA BMW, AUSTIN, AUDI, VW
17MM	GENERAL MOTOR
3/8"	BMW, RENAULT, TOYOTA
10MM	CITROEN, PEUGEOT, RENAULT, TALBOT, VOLVO
8MM	FORD
11MM	NISSAN, SUBARU
13MM	HONDA, NAZDA, RENAULT, SAAB, VOLVO
3/8"	GENERAL MOTOR
7MM	
10MM	RENAULT
T-BAR TO DRIVE	
30-16MM OIL FILTER CHAIN WRENCH	
3/8" OIL FILTER CAP WRENCH	
93MM-15	GM, NISSAN, VOLVO, MAZDA, AUDI, V W, ETC
76MM-14	V W, PORSCHE, MERCEDES, BM W, TOYOTA
75.6MM-14	MAZDA, GENERAL MOTOR
38MM	ETC DIESEL ENGINE
36MM	BENZ, V W, BM W/M52, M60, M73
32MM	GM, SAAB, SATUM
30MM	GENERAL MOTOR
27MM	MERCEDES
24MM	BM W/5 & 7 SERIES

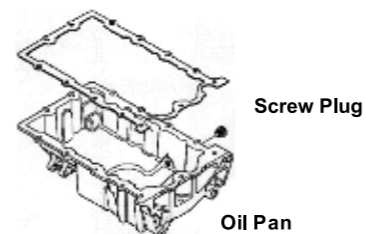
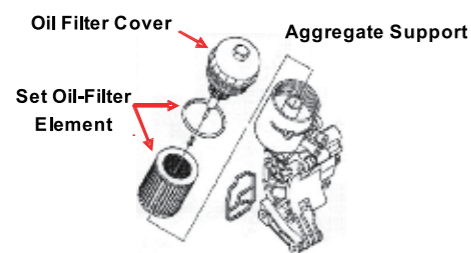

MTC101SP 7PC. PRECISION MEASURING TOOL KIT

- MTC 150 - LARGE RANGE ELECTRONIC CALIPER. SIZE : 6" DIMENSION : 150X0.01MM
- EASY TO READ DIGITAL LARGE LCD DISPLAY WITH INCH / METRIC CONVERSION.
- MADE FROM HARDENED , STAINLESS STEEL.
- MTC 153 - PRECISION ALUMNUM SQUARE. SIZE : 300MM DIMENSION : 300X4X1.0
- SHORT/LONG-HANDLE ALUMINUM/STAINLESS STEEL.
- SURFACE TREATMENT : POLISHED FINISH. • TEST STANDARD : 90° ± 0.2°
- MTC 306 - QUICK ADJUST DIVIDERS. SIZE : 6"
- EASY ADJUST. • POLISH FINISH.
- MATERIAL : CARBON STEEL.
- MTC 155 - UTILITY TECHNICAL PENCIL. SIZE : 2.0MM
- TECHNICAL PENCIL WITH TUNGSTEN LEAD.
- MTC 156 - STAINLESS STEEL RULER. SIZE : 12" / 30CM DIMENSION : 334X23.7X1.0
- SURFACE TREATMENT : POLISHED FINISH.
- PROCESS OF SCALE : ACID- ETCHED.
- MTM 1025 - MICROMTERS. SIZE : 0-25MM
- SATIN CHEOME FINISH THIMBLE AND HANDLE WITH EASY READING.
- MTM 1050 - MICROMTERS. SIZE : 25-50MM
- SATIN CHEOME FINISH THIMNLE AND HANDLE WITH EASY READING.



JONNESWAY

V1310SP 70PC. CRIMPER AND STRIPPER ASSORTED TERMINALS TOOL KIT

- V13-SMART VISE CRIMER SERIES. LENGTH : 9-3/4"(247MM)
- HRC 48° ~ 52° MIDDLE CARBON STEEL BODY WITH COMFORTABLE TPR HANDLE THAT LESS TIRED FOR LONG TIME CRIMPING.
- V1310A-SMART VISE CRIMER- A TYPE.
- SUITABLE FOR INSULATED TERMINALS / COLOR NESTS.
- 22-10 AWG (0.5MM-6MM).
- V1310B-SMART VISE CRIMER- B TYPE.
- SUITABLE FOR NON-INSULATED OPEN BARREL CONNECTORS , COMMERCIAL TYPE.
- 22-10 AWG (0.5MM-6MM).
- V1310E-SMART VISE CRIMER- E TYPE.
- SUITABLE FOR NON-INSULATED TERMINALS . • 22-8 AWG (0.5MM-10MM).
- V1401-PROFESSIONAL CRIMPING TOOL & WIRE STRIPPER.
- 1PC - #2.5 HEX KEY WRENCH.
- 2PC - REPLACEABLE SCREWS.
- 60PCS - TERMINALS KIT.
- AR030044 - CORDLESS CIRCUIT TESTER.
- DETECTS FROM 3 TO 28 VOLTS . • SAFE WITH ECMS , SENSORS , TEANSDUCERS , AIRBAGS , ETC. • NO GROUND WIRE OR CLIP REQUIRED.
- REPLACEABLE LONG-LIFE AIKALINE BATTERIES INCLUDED.
- AG010031A - 2 IN1 TELESOPIC MIRROR WITH MAGNETIC END.





S04H4125SP 25PCS 1/2" DR. 6PT FLANK SOCKET SET

CONTENTS:

S04H4	18PCS-1/2" DR. SOCKETS : 10, 11, 12, 13, 14, 15, 16, 17, 18, 19, 20, 21, 22, 23, 24, 27, 30, 32MM
S17H4	2PCS-SPARK PLUG SOCKETS : 16 & 21MM
S24H4	2PCS EXTENSION BARS : 5" & 10"
S23H4125	1PC-SLIDING T BAR
S15H472	1PC-UNIVERSAL JOINT
R3704	1PC-12" DR. 48 TEETH QUICK RELEASE RATCHET HANDLE

JONNESWAY

S04H3157SP 57PCS 1/4" & 3/8" DR. 6PT FLANK SOCKET SET

CONTENTS:

S04H2	12PCS-1/4"DR.SOCKETS:4,4.5,5.5,6,7,8,9,10,11,12,13,MM
S04HD2	4PCS-1/4"DR.DEEP SOCKET:8,10,12,13,MM
S04H3	8PCS-3/8"DR.SOCKETS:14,15,17,18,19,20,22,24,MM
S04HD3	3PCS-3/8"DR.DEEP SOCKET:14,15,17,MM
R3702	1PC-1/4"DR.48TEETH QUICK RELEASE RATCHET HANDLE
R3703	1PC-3/8"DR.48TEETH QUICK RELEASE RATCHET HANDLE
S24H2	2PCS-EXTENSION BAR:1/4"DR.X 50MM,150MM
S24H3	2PCS-EXTENSION BAR: 3/8"DR.75MM,250MM
S16H302	1PC-ADAPTER FOR EXTENSION BAR 3/8"(F)X1/4"(M)
S16H304	1PC-ADAPTER FOR EXTENSION BAR 3/8"(F)X1/2"(M)
S17H3	2PCS-3/8"DR.SPARK PLUG SOCKET:16MM,21MM
S15H2	1PC-1/4"DR.UNIVEER JOINT
S15H3	1PC-3/8"DR.UNIVEER JOINT
S26H2	1PC-1/4"DR.SPINNER HANDLE
16PCS: 1/4"DR.BIT SOCKET L:32MM	
S10H2	3PCS-SLOTTED BIT SOCKET:4,5.5,7,MM
S09H2	4PCS-HEX BIT SOCKET :3,4,5,6,MM
S07H2	6PCS-STAR BIT SOCKET :T10,T15,T20,T25,T27,T30,
S11H2	3PCS-PHILLIPS BIT SOCKET:PH1,PH2,PH3,



JONNESWAY

S04H3536SP 36PCS 3/8" DR. SOCKET & COMBINATION WRENCH SET

CONTENTS:

S04H3	17PCS-3/8" DR. 6PT FLANK SOCKETS : 6, 7, 8, 9, 10, 11, 12, 13, 14, 15, 16, 17, 18, 19, 21, 22MM
W261	11PCS-COMBINATION WRENCH : 7, 8, 9, 10, 11, 12, 13, 14, 15, 16, 17MM
R3403	1PC-72 TEETH RATCHET HANDLE
S24H3	3PCS-EXTENSION 3", 6", 9"
S17H3	2PCS-SPARK PLUG SOCKET, 16, 21MM
S15H356	1PC-UNIVERSAL JOINT
S16H403	1PC-ADAPTOR FOR EXTENSION, 1/2"(F)X3/8"(M)



JONNESWAY

S05H4238SP 38PCS 1/2" DR. SOCKET SET

CONTENTS:

S05H42	9PCS-1/2" DR. 12PT SOCKETS (CR-V) : 7/16", 1/2", 9/16", 5/8", 11/16", 3/4", 13/16", 7/8", 15/16"
S05H41	9PCS-1/2" DR. 12PT SOCKETS (CR-V) : 11, 12, 13, 14, 15, 17, 18, 19, 20MM
S05HD42	9PCS-1/2" DR. 6PT DEEP SOCKETS (CR-V) : 7/16", 1/2", 9/16", 5/8", 11/16", 3/4", 13/16", 7/8", 15/16"
S05HD41	9PCS-1/2" DR. 6PT DEEP SOCKETS (CR-V) : 11, 12, 13, 14, 15, 17, 18, 19, 20MM
R2804Q	1PC-1/2" DR. 10" QUICK RELEASE RATCHET HANDLE - 48 TEETH
S24HC4125	1PC-1/2" DR. 5" EXTENSION BAR (CR-V)



M645115SP 15PCS HACKSAW, CHISEL, PUNCH & ADJUSTABLE WRENCH SET

CONTENTS:

M63106S	6PCS-PIN PUNCH SET, BLACK FINISH : 2x8x115MM, 3x8x125MM, 4x9.5x150MM, 5x9.5x165MM, 6x12.7x180MM, 8x12.7x180MM
M64105S	5PCS-CHISEL PUNCH SET/BLACK FINISH : TAPER PUNCH : 6x9.5x120MM, CENTER PUNCH : 2x9.5x120MM CAPE CHISEL : 5x9.5x130MM, COLD CHISEL : 12x9.5x130MM, PIN PUNCH: 4x9.5x150MM
W27AS10	1PC-10" ADJUSTABLE WRENCH W/SAE & MM SCALE
MHS100AG	3PCS-HACKSAW SET : 1PC HEAVY DUTY DELUXE TYPE HACKSAW & 2PCS-SPARE SAW BLADE

JONNESWAY

H10MB08SP 8PCS TWO WAY BALL POINT & HEX KEY SET

CONTENTS:

H10MB08S	8PCS-2x100, 2.5x100, 3x100, 4x100, 5x150, 6x150, 8x200, 10x200mm
----------	--



JONNESWAY

H10MT08SP 8PCS TWO WAY STAR & TAMPERPROOF KEY SET, SNCM+V, MAT FINISHED

CONTENTS:

H10MT	T10X100, T15X100, T20X100, T25X100, T27X150, T30X150, T45X200, T50X200
-------	--



JONNESWAY

W26116SP 16PCS COMBINATION WRENCH SET

CONTENTS:

W261	16PCS-COMBINATION WRENCH : 6, 7, 8, 9, 10, 11, 12, 13, 14, 15, 16, 17, 18, 19, 22, 24MM
------	---





C-6DA4 6 DRAWER TOOL MEDIUM TOP CHEST

	W	D	H	
OVERALL	26"	12"	15"	Inch
	660	305	380	mm
3 DRAWERS	6.7"	10.5"	1.6"	Inch
	172	270	41	mm
2 DRAWERS	22.5	10.5"	1.6"	Inch
	572	270	41	mm
1 DRAWER	22.5	10.5"	2.5"	Inch
	572	270	65	mm
	N.W.	G.W.	CUFT	
	23kgs	26.9kgs	3.97'	

- Steel thickness : Top chest : 1.0mm drawer, 1.0mm body, 1.0mm drop-front.
- 100% open ball bearing slide on small and full-width drawer.
- Easy move ball bearing drawer slides on all drawers for professional use.
- Drawer dentent (stopper) to prevent unintentional opening of drawer for replacement.

JONNESWAY



C-6DA6 6 DRAWER TOOL LARGE TOP CHEST

	W	D	H	
OVERALL	26"	18"	19"	Inch
	660	455	484	mm
5 DRAWERS	22.8"	15"	1.83"	Inch
	579	380	46.6	mm
1 DRAWER	22.8	15"	2.2"	Inch
	579	380	56	mm
	N.W.	G.W.	CUFT	
	46.5kgs	52.5kgs	8.5'	

- Ball bearing slides
- Steel thickness : 1.0mm
- Top chest, 1.0mm body.

JONNESWAY



C-T5 WORKBENCH WITH 3 DRAWER CHEST (BALL BEARING SLIDE)

	W	D	H	
OVERALL	59"	27.5"	59"	Inch
	1500	700	1500	mm
3 DRAWERS	26"	12"	9.8"	Inch
	660	305	250	mm
	N.W.	G.W.	CUFT	
	71kgs	74.5kgs	7.74'	



C-HA TETORON TOOL BAG
• SIZE - 620X250X310MM

JONNESWAY



C-3DH2 3-SECTIONS PORTABLE TOOL CHEST
• SIZE : 470mm x 220mm 350mm

JONNESWAY



C-3DH203 66PCS TOOL CHEST SET
• SIZE : 470mm x 220mm 350mm

CONTENTS:

W27AS10	1PC-10" ADJUSTABLE WRENCH
M07016	1PC-16 OZ SOFT FACE HAMMER
M09300	1PC-300g ENGINEER HAMMER
P2710	1PC-10" MACHINED TONGUE & GROOVE WATER PUMP PLIER
P106	1PC-6" DIAGONAL CUTTER PLIER
P116	1PC-6" LONG NOSE PLIER
P087	1PC-7" SIDE CUTTING PLIER
H01M109S	9PCS-HEX KEY SET (1.5, 2, 2.5, 3, 4, 5, 6, 8, 10)
S04H41	18PCS-1/2" DR. SOCKET (10-32mm)
W25	8PCS-OPEN END WRENCH (6-22mm)
W23	8PCS-75° OFFSET WRENCH (6-22mm)
M64105S	5PCS-CHISEL - PUNCH SET
D70	6PCS - THRU SCREWDRIVER SET
C-3DH2	1PC-PORTABLE TOOL
R3704	1PC-1/2" DR. QUICK RELEASE 48 TEETH RATCHET HANDLE W/ANTI SLIP GIRIP
S15H472	1PC-1/2" DR. UNIVERSAL JOINT
S24H4	2PCS-EXTENSION BAR 5", 10"

JONNESWAY



C-3DH262 62PCS TOOL CHEST SET
CHEST SIZE: 470 X 220 X 350MM

CONTENTS:

S04H4120ST	18PCS 1/2" DR. SOCKET (S04H4): 10 - 32MM
	18PCS COMBINATION WRENCH (W26): 6 - 22, 24MM
	9PCS EXTRA LONG ARM HEX KEY (H03SM109S)
	SIZE:1.5, 2, 2.5, 3, 4, 5, 6, 8, 10MM
D70SP06ST	6PCS GO-THRO SCREWDRIVER (D70) : PH#1X75, PH#2X100, PH#3X150, 5.5X100, 6.5X150, 8.0X175
	1PC 7" COMBINATION PLIERS (P087)
	1PC 6" DIAGONAL CUTTER PLIER (P106)
	1PC 6" LONG NOSE PLIERS(P116)
	1PC 1/2" DR. ANTI-SLIP RATCHET HANDLE (R2904)
	2PCS 1/2" DR. EXTENSION BAR: 125, 250MM (S24H4)
	1PC 1/2" DR. SLIDING T-BAR 300MM (S23H41300)
	1PC 1/2" DR. FLEXIBLE HANDLE 450MM (S22H41450)
	1PC 1/2" DR. UNIVERSAL JOINT (S15H472)
	1PC 1/2" DR. WOBBLE EXTENSION BAR (S21H4150)
	1PC 1/2" DR. SPARK PLUG 21MM (S17H4121)
	1PC 3-SECTIONS PORTABLE TOOL CHEST (C-3DH2)



C-A3 HANDLE

Designed for :
C-5DW1, C-5DW2, C-7DW1, C-7DW2,
C-6DW1, C-6DW2, C-4DW1, C-4DW2

JONNESWAY



C-A3B HANDLE

Designed for :
C-5DW1, C-5DW2, C-7DW1, C-7DW2,
C-6DW1, C-6DW2, C-4DW1, C-4DW2

JONNESWAY



C-A456 WORKING TABLE SET

CONTENTS:

C-A4	PLASTIC HANDLE
C-A5	WORKING TABLE
C-A6	PLASTIC HOLDER

JONNESWAY



C-A8 4" ALL STEEL SWIVEL-BASE VISE

C-A11 6" ALL STEEL SWIVEL-BASE VISE

C-A13 10" ALL STEEL SWIVEL-BASE VISE

Only 3" & 4" for C A9 working bench

JONNESWAY



C-DB HOOKS FOR:C-T5

C-DBU7	2" SINGLE HOOK
C-DBU3	4" SINGLE HOOK



JONNESWAY®



TORQUE WRENCH SERIES

- Professional Quality meets ANSI/DIN Standards
- Special Oil-Resistance Handle
- Accuracy to $\pm 3\%$ of Set Load
- Regular and Window Scale to Meet All Demands
- Also Available in Digital Torque Wrench

T21 MICROMETER TORQUE WRENCH

Accuracy: ±3%

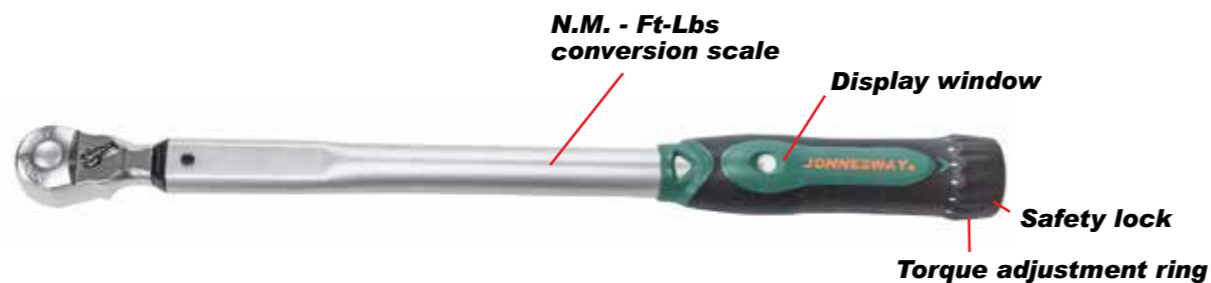

Operation Manual

1. Switch the **safety lock** in the bottom of the handle to the left to unlock. *Attention: Failing to unlock the safety lock before adjusting the torque setting will seriously damage the lock function.*
2. Once the **safety lock** is unlocked, turn the **torque adjustment ring** until the **display window** shows the desired torque setting. Then turn the safety lock to the right to lock the setting.



Attention: When turning the torque adjustment ring, DO NOT exceed the maximum torque, or the inner mechanism will be seriously damaged.

3. Zero the torque wrench after operation.

Attention: When zeroing the torque wrench, DO NOT exceed the "Stop" sign shown in the display window

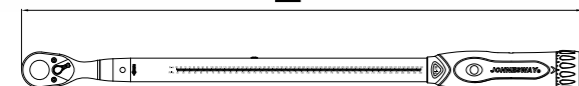

- Accuracy: ±3%
- Torque setting is displayed in numbers, easy to identify the torque settings
- With soft handle to increase work comfort

Application: For industrial market, such as automobile assembly line, production line, etc.

T21		MICROMETER TORQUE WRENCH (RIGHT HAND)				
ITEM NO.	SQUARE DRIVER	RANGE	L (mm)	WEIGHT (kg)	PACKING PCS/CTN	
T21025N	1/4"	5-25N.m.	343	0.8	6	
T21026N	3/8"	5-25N.m.	343	1	6	
ITEM NO.	SQUARE DRIVER	RANGE	L (mm)	WEIGHT (kg)	PACKING PCS/CTN	
T21020F	1/4"	4-20Ft-Lbs	343	1	6	
T21035F	3/8"	7-35Ft-Lbs	420	1	6	
T21076F	1/2"	15-75Ft-Lbs	420	1.2	6	
T21250F	1/2"	50-250Ft-Lbs	640	1.8	4	

T27 ADJUSTABLE TORQUE WRENCH

Accuracy: ±4%

- **Unlock:** Push the handle back to unlock. (Smart design: users do not have to hold still the handle to keep it unlocked)



- **Lock:** After setting the desired torque, push the handle forward to lock.



- **Handle position:** Make sure to keep hands on the centered handle.



Make sure to keep hands centered on the handle.

- **Operate:** Make sure to use the torque wrench with a stable force and stop the operation when hearing the sound "click". It means the desired torque is reached.



Operating
Make sure to apply with a slow regular force when pulling until a "CLICK" sound is heard or felt. Then please STOP pulling.

- **Setting:** Users set torque as the drawing below (EX : 66N.m)



*Conversion table

Torque Conversion Table				
	kgf-m	N-m	Ft-lb	In-lb
kgf-m	1	0.102	0.14	0.012
N-m	9.8	1	1.36	0.11
Ft-lb	7.23	0.74	1	0.08
In-lb	86.72	8.85	12	1

Application: For professional market, such as garages, workshops, car repair and maintenance

T27 ADJUSTABLE TORQUE WRENCH (RIGHT HAND)

ITEM NO.	SQUARE DRIVE	RANGE	L (mm)	WEIGHT (kg)	PACKING PCS/CTN
T27010N	1/4"	2~10 NM	371	0.6	25
T27030N	1/4"	4.5~30 NM	371	0.6	25
T27031N	3/8"	4.5~30 NM	371	0.6	25
T27100N	3/8"	20~100 NM	464	1.1	12
T27200N	1/2"	40~200 NM	531	1.4	12
T27340N	1/2"	60~340 NM	585	1.5	12
T27500N	3/4"	100~500 NM	847	3.9	4
T27800N	3/4"	150~800 NM	1090	4.9	2
T271000N	3/4"	200~1000 NM	1090	4.9	2
T271001N	1"	200~1000 NM	1090	4.9	2

ITEM NO.	SQUARE DRIVE	RANGE	L (mm)	WEIGHT (kg)	PACKING PCS/CTN
T27100F	3/8"	15~100 FT-LB	464	1.1	12
T27150F	1/2"	20~150 FT-LB	531	1.4	12
T27250F	1/2"	30~250 FT-LB	585	1.5	12
T27600F	3/4"	100~600 FT-LB	1090	4.9	2
T27750F	3/4"	150~750 FT-LB	1090	4.9	2
T27751F	1"	150~750 FT-LB	1090	4.9	2



T09 TORQUE MULTIPLIER

ITEM NO.	NPUT DR. (FEMALE)	OUTPUT DR. (MALE)	GEAR RATIO	WIDTH (MM)	HEIGHT (MM)	MAX. OUTPUT TORQUE (N-M)
T094602	1/2" DR.	3/4" DR.	1:9	82	98	1500

- Accuracy: ± 10%
- Warning: Do not use with impact wrench.

JONNESWAY

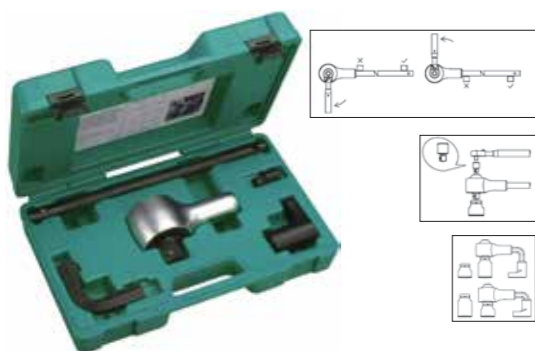

T09 TORQUE MULTIPLIER SET

ITEM NO.	TORQUE RATIO	MAX. INPUT TORQUE	MAX. OUTPUT TORQUE	STRAIGHT REACTION BAR	90° REACTION BASE BAR	BREAK-AWAY SAFETY ADAPTER
T09682500	1 : 3.3	3/4"Dr.× 758N-m (560F-lb)	1"Dr.× 2500N-m (1850F-lb)	1PC	1PC	2PCS

- Accuracy: ± 10%
- Warning: Do not use with impact wrench.

JONNESWAY



T30200NS 11PCS INTERCHANGEABLE TORQUE WRENCH SET (14X18)

ITEM NO.	CONNECT HEAD SIZE	TORQUE RANGE	WEIGHT (G)
T30200NS	14x18	40~200NM	3847



R66 RATCHET HANDLE - 60 TEETH

- High quality material
- Ergonomic grip
- Anti Slip handle
- Rotating Function
- Pushable head

• The anti slip ratchet handle is specially designed with rotating function. Users can remove or install nuts and bolts by rotating without operation back and forth in confined spaces. The rotating function could be adjusted freely by pushing or pulling the head back for forward and reverse direction. The R66 series is ideal for limited area usage.

ITEM	SIZE	GEAR TEETH	L (mm)	WIDTH	HEIGHT	WEIGHT
R6602	1/4"	60	180	27	23	181
R6603	3/8"	60	240	36	29	384
R6604	1/2"	60	290	42	37	645



JONNESWAY



RD0503 3/8" DR. SWIVEL PALM RATCHET

JONNESWAY



RD0502 1/4" DR. SWIVEL PALM RATCHET

JONNESWAY



RD05H2 1/4" DR. SWIVEL PALM RATCHET (BIT HOLDER)

JONNESWAY



RD05H22S 22PCS GO-THRU SWIVEL PALM RATCHET SET

- Contents:
- 1PC-GO-THRU SWIVEL PLAM RATCHET W/ 1/4"DR. SWIVEL ADAPTER
- 11PCS-GO-THRU SOCKETS (MM/SAE): 4.5mm(3/16"), 5mm(13/64"), 5.5mm(7/32"), 6mm(1/4"), 7mm(9/32"), 8mm(5/16"), 9mm(11/32"), 10mm(3/8"), 11mm(7/16"), 12mm(15/32"), 13mm(1/2")
- 1PC-BIT HOLDER
- 1PC-2" EXTENSION BAR
- 8PCS-BITS (T10, T15, T20, T25, PH1, PH2, PH3, SLOTTED 6.5mm)





R36	LEVER TYPE RATCHET HANDLE-48 TEETH							
	<ul style="list-style-type: none"> • HANDLE-CHROME VANADIUM STEEL • DRIVER-CHROME MOLYBDENUM STEEL • FULLY POLISHED • QUICK RELEASE 							

ITEM NO.	DRIVE	WIDTH (mm)	HEIGHT (mm)	L (mm)	WEIGHT (g)	TORQUE (NM)	PACKING	
							INNER PC/BOX	OUTER PC/CTN
R3602	1/4"	22	22	128	100	68	10	60
R3603	3/8"	30	29	198	280	245	10	40
R3604	1/2"	42	38	250	620	647	5	30

JONNESWAY



R37	ANTI-SLIP GRIP RATCHET HANDLE-48 TEETH							
	<ul style="list-style-type: none"> • HANDLE-CHROME VANADIUM STEEL • DRIVER-CHROME MOLYBDENUM STEEL • SATIN FINISHED • QUICK RELEASE 							

ITEM NO.	DRIVE	WIDTH (mm)	HEIGHT (mm)	L (mm)	WEIGHT (g)	TORQUE (NM)	PACKING	
							INNER PC/BOX	OUTER PC/CTN
R3702	1/4"	23	22	135	115	68	10	60
R3703	3/8"	30	29	198	280	245	5	40
R3704	1/2"	42	38	253	620	647	5	30

JONNESWAY



R38	LEVER TYPE STUBBY RATCHET HANDLE-48 TEETH							
	<ul style="list-style-type: none"> • HANDLE-CHROME VANADIUM STEEL • DRIVER-CHROME MOLYBDENUM STEEL • FULLY POLISHED • QUICK RELEASE 							

ITEM NO.	DRIVE	WIDTH (mm)	HEIGHT (mm)	L (mm)	WEIGHT (g)	TORQUE (NM)	PACKING	
							INNER PC/BOX	OUTER PC/CTN
R3802	1/4"	22	22	90	80	68	10	60
R3803	3/8"	30	29	115	180	245	10	40
R3804	1/2"	42	38	150	420	647	5	30

JONNESWAY



R29	ANTI-SLIP GRIP RATCHET HANDLE-36 TEETH							
	<ul style="list-style-type: none"> • HANDLE-CHROME VANADIUM STEEL • DRIVER-CHROME MOLYBDENUM STEEL • SATIN FINISHED • QUICK RELEASE 							

ITEM NO.	SIZE	L (mm)	WIDTH	HEIGHT	WEIGHT	PACKING	
						INNER PC/BOX	OUTER PC/CTN
R2902	1/4"Dr.	146	26	22	120	25	100
R2903	3/8"Dr.	185	32	30	265	12	48
R2904	1/2"Dr.	278	40	38	570	6	24

JONNESWAY



R42	STUBBY FLEXIBLE RATCHET HANDLE WITH ANTI-SLIP GRIP-36 TEETH							
	<ul style="list-style-type: none"> • HANDLE-CHROME VANADIUM STEEL • DRIVER-CHROME MOLYBDENUM STEEL • CHROME PLATED • QUICK RELEASE 							

ITEM NO.	SIZE	L (mm)	WIDTH	HEIGHT	WEIGHT (g)	PACKING	
						INNER PC/BOX	OUTER PC/CTN
R4202	1/4" DR.	125	27	25	140	25	100
R4203	3/8" DR.	156	32	33	306	12	48
R4204	1/2" DR.	191	42	42	540	6	24



R06	HEAVY DUTY QUICK RELEASE RATCHET HANDLE-24 TEETH							
	<ul style="list-style-type: none"> • HANDLE-CHROME VANADIUM(SAE6140) STEEL • DRIVER-CHROME MOLYBDENUM STEEL • FULLY POLISHED • QUICK RELEASE 							

ITEM NO.	DRIVE	D1 (mm)	T (mm)	L (mm)	WEIGHT (KGS)	PACKING	
						INNER PC/BOX	OUTER PC/CTN
R0602	1/4"	28	11.2	141	0.16	10	100
R0603	3/8"	36	15	195	0.35	10	50

JONNESWAY



R48	ANTI SLIP GRIP RATCHET HANDLE-72 TEETH							
	<ul style="list-style-type: none"> • HANDLE-CHROME VANADIUM STEEL • DRIVER-CHROME MOLYBDENUM STEEL • SATIN FINISHED • QUICK RELEASE 							

ITEM NO.	SIZE	L (mm)	WIDTH	HEIGHT	WEIGHT	PACKING	
						INNER PC/BOX	OUTER PC/CTN
R4802	1/4"Dr.	146	26	22	120	25	100
R4803	3/8"Dr.	185	32	30	265	12	48
R4804	1/2"Dr.	278	40	38	570	6	24

JONNESWAY



R49	FLEXIBLE RATCHET HANDLE-72 TEETH							
	<ul style="list-style-type: none"> • HANDLE-CHROME VANADIUM STEEL • DRIVER-CHROME MOLYBDENUM STEEL • FULLY POLISHED • QUICK RELEASE 							

ITEM NO.	SIZE	L (mm)	WIDTH	HEIGHT	WEIGHT (g)	PACKING	
						INNER PC/BOX	OUTER PC/CTN
R4902	1/4" DR.	141	27	25	167	25	100
R4903	3/8" DR.	288	32	33	480	6	36
R4904	1/2" DR	310	42	42	798	6	24

JONNESWAY



R51	RATCHET EXTENDABLE HANDLE - 72TEETH							
	<ul style="list-style-type: none"> • HANDLE- CHROME VANADIUM STEEL • DRIVER-CHROME MOLYBDENUM STEEL • CHROME PLATED 							

ITEM NO.	DRIVER	LENGTH (mm)
R5104	1/2"DR.	300-440

JONNESWAY



(24 TEETH)

R12	3/4" DR. REVERSIBLE RATCHET HANDLE		
	<ul style="list-style-type: none"> • HANDLE-CHROME VANADIUM STEEL • DRIVER-CHROME MOLYBDENUM STEEL • CHROME PLATED 		

ITEM NO.	SIZE	L (mm)	WEIGHT (kg)
R1206	3/4" Dr.	500	1.8

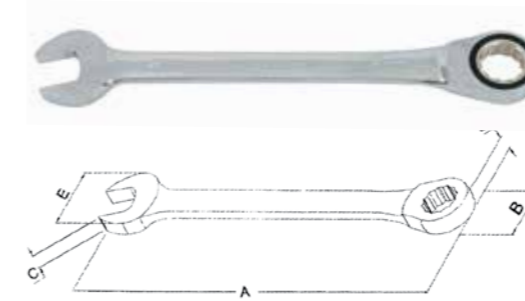

PRODUCTS' FUNCTIONS AND SPECIAL FEATURES:

1. 72 Teeth ratcheting gear creates high torque and 5 degrees each catch for operation in tight space.
2. Chrome-Vanadium steel and special heat treatment provide thin walls with special strength.
3. Mirror Polished.
4. Meeting ANSI Standard.

W45 72 TEETH RATCHETING COMBINATION WRENCH
• CHROME VANADIUM • MIRROR POLISHED

ITEM NO.	SIZE (metric)	A (mm)	B (mm)	C (mm)	D (mm)	E (mm)	WEIGHT (g)	PACKING	
								INNER PC/BOX	OUTER PC/CTN
W45108	8	135.4	17.1	4.9	6.9	16.55	38	12	120
W45109	9	159.5	20.7	5.8	7.5	20.2	60	12	120
W45110	10	159.5	20.7	5.8	7.5	20.2	60	12	120
W45111	11	165.9	22.6	6.0	8.3	22.4	68	12	120
W45112	12	168.6	23.8	6.2	8.3	24.9	84	12	120
W45113	13	178.5	24.9	6.5	8.5	26.4	94	12	120
W45114	14	190.5	27.0	7.0	8.6	28.24	104	12	120
W45115	15	199.4	28.1	7.2	9.6	31.0	130	12	120
W45116	16	206.4	29.9	7.8	9.6	33.27	148	12	120
W45117	17	225.4	31.9	8.2	19.8	35.53	192	12	72
W45118	18	236.4	33.4	8.6	10.6	36.4	192	12	72
W45119	19	247.4	34.4	8.8	10.6	38.4	240	12	72
W45121	21	281	42.6	9.5	13.0	45.7	390	6	48
W45122	22	281	42.6	9.5	13.0	45.7	390	6	48
W45123	23	311	46.5	10.0	13.5	51.7	520	6	48
W45124	24	311	46.5	10.0	13.5	51.7	520	6	36

JONNESWAY



W45107S 7PCS 72 TEETH RATCHETING COMBINATION WRENCH SET(MM)
Contents : 10, 12, 13, 14, 15, 17, 19MM
Packing : PLASTIC HOLDER
20SETS/CTN/26KGS/28KGS/2.2'

JONNESWAY



W45208S 8PCS 72 TEETH RATCHETING COMBINATION WRENCH SET(SAE)
Contents : 5/16", 3/8", 7/16", 1/2", 9/16", 5/8", 11/16", 3/4"
Packing : PLASTIC HOLDER
10SETS/CTN/19.2KGS/20.5KGS/1.2'

WRENCH SERIES

- Professional Quality: ANSI / DIN Standards
- Super Torque: 1.3 times as ANSI & 1.5 times as DIN
- Metric Size & SAE Size
- Full Ranges including Jumbo Type
- Mirror Polished & Matt Finished
- Flank Points to Protect Nuts
- 5 Degree Each Catch for 72 Teeth Ratcheting Combination Wrench





W45117S 72 TEETH RATCHETING COMBINATION WRENCH SET

CONTENTS:

4PCS - ADAPTER : 3/4", 1/2", 3/8", 1/4" DR.
13PCS - 72 TEETH RATCHETING COMBINATION WRENCH : 8, 10, 12, 13, 14, 17, 19, 21, 22, 24, 27 30, 32MM
1 PC BIT ADAPTER : 1/4"

JONNESWAY



W45508S 8 PCS 72 TEETH RATCHETING COMBINATION WRENCH SET

CONTENTS:

- 4 PCS-RATCHETING COMBINATION WRENCH :10,13,17,19 MM
- 3 PCS-SOCKET ADAPTOR WITH QUICK RELEASE :1/4",3/8",1/2"DR.
- 1/4"DR. SOCKET ADAPTOR FOR 10MM RATCHETING WRENCH
- 3/8"DR. SOCKET ADAPTOR FOR 13MM RATCHETING WRENCH
- 1/2"DR. SOCKET ADAPTOR FOR 19MM RATCHETING WRENCH
- 1PC- BIT HOLDER FOR 10MM RATCHETING WRENCH
- Packing:BLOW CASE

JONNESWAY



W45110S 10PCS 72 TEETH RATCHETING COMBINATION WRENCH SET

Contents :

6PCS-RATCHETING WRENCH:8, 10, 12, 13, 17, 19MM
3PCS-SOCKET ADAPTOR WITH QUICK RELEASE:1/4", 3/8", 1/2" DR.
1PC-BIT HOLDER
Packing : BLOW CASE

JONNESWAY

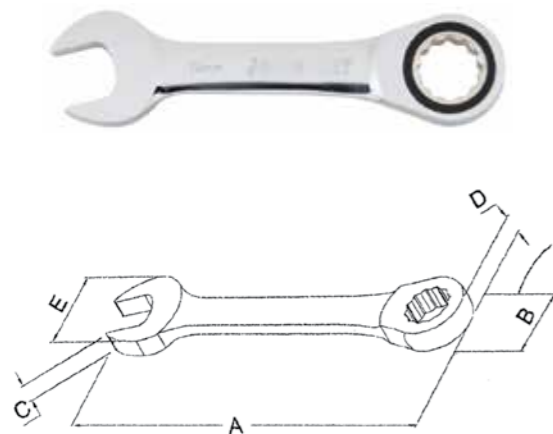

W51 72 TEETH RATCHETING COMBINATION WRENCH (STUBBY TYPE)

ITEM NO.	SIZE (metric)	A (mm)	B (mm)	C (mm)	D (mm)	E (mm)	WEIGHT (g)
W51108	8	93.0	17.4	4.9	7.4	16.53	30
W51109	9	95.4	20.9	5.8	7.4	20.19	40
W51110	10	95.4	20.9	5.8	7.4	20.19	40
W51111	11	105.0	23.4	6.2	8.7	25.1	60
W51112	12	105.0	23.4	6.2	8.7	25.1	60
W51113	13	106.4	24.9	6.4	8.7	26.64	65
W51114	14	115.0	27.4	7.0	8.7	28.3	85
W51115	15	112.0	30.4	7.8	10.3	33.3	110
W51116	16	122.0	30.4	7.8	10.3	33.3	110
W51117	17	125.4	31.9	8.2	10.3	35.5	130
W51118	18	138.0	33.9	9.2	10.3	39.6	160
W51119	19	138.0	33.9	9.2	10.3	39.6	165

- 72 Teeth ratcheting system provides high torque and 5 degrees of operation in tight areas
- Chrome Vanadium steel and special heat treatments provide thin walls for strength
- Mirror Polished
- Meeting ANSI Standard

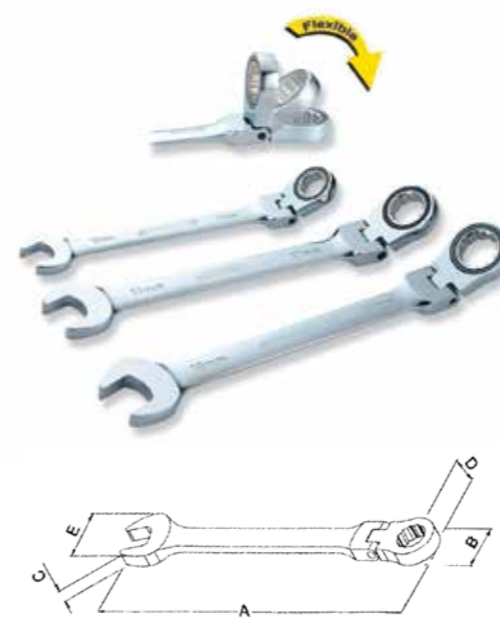

JONNESWAY

W66 FLEXIBLE 72 TEETH RATCHETING COMBINATION WRENCH

ITEM NO.	SIZE (metric)	A (mm)	B (mm)	C (mm)	D (mm)	E (mm)
W66108	8	137	17.4	4.9	7.4	16.95
W66109	9	159	20.9	5.8	7.4	20.8
W66110	10	159	20.9	5.8	7.4	20.8
W66111	11	175	23.4	6.2	8.7	25.1
W66112	12	175	23.4	6.2	8.7	25.1
W66113	13	186	24.9	6.4	8.7	27.15
W66114	14	194	27.4	7.0	8.7	29.3
W66115	15	216	30.4	7.4	10.3	33.0
W66117	17	232	31.9	8.2	10.3	35.2
W66119	19	250	33.9	9.2	10.3	39.4

• Packing : w/plastic hanger

JONNESWAY



W66107S 7 PCS FLEXIBLE 72 TEETH RATCHETING COMBINATION WRENCH SET (MM)

Contents : 8, 10, 11, 13, 14, 17, 19MM
Packing : PLASTIC DEMO BOX
20SETS/CTN/26KGS/28KGS/2.2'

JONNESWAY

W66207S 7 PCS FLEXIBLE 72 TEETH RATCHETING COMBINATION WRENCH SET (SAE)

Contents : 3/8", 7/16", 1/2", 9/16", 5/8", 11/16", 3/4"
Packing : PLASTIC DEMO BOX
20SETS/CTN/26KGS/28KGS/2.2'

JONNESWAY

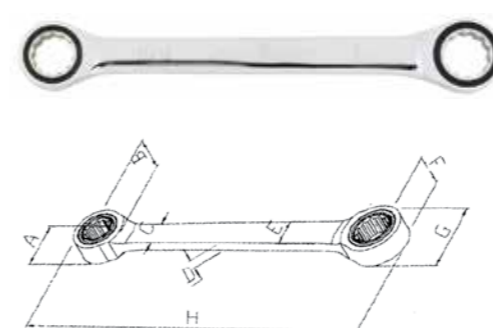

W68 72 TEETH RATCHETING BOX END WRENCH

ITEM NO.	SIZE (MM)	A (mm)	B (mm)	C (mm)	D (mm)	E (mm)	F (mm)	G (mm)	H (mm)
W680809	8 X 9	φ 17.4	7.4	8.6	3.4	10.3	7.4	φ 20.9	130.4
W680810	8 X 10	φ 17.4	7.4	8.6	3.4	10.3	7.4	φ 20.9	130.4
W681011	10 X 11	φ 20.9	7.4	10.3	3.6	11.3	8.7	φ 22.9	144.4
W681213	12 X 13	φ 23.4	8.7	11.5	4	12.3	8.7	φ 24.9	166.0
W681415	14 X 15	φ 27.4	8.7	13.5	4.5	15.0	10.3	φ 30.4	181.4
W681618	16 X 18	φ 30.4	10.3	15.0	5	16.8	10.3	φ 33.9	205.9
W681719	17 X 19	φ 31.9	10.3	15.5	5.2	17.0	10.3	φ 34.4	224.4

- 72 Teeth ratcheting system provides high torque and 5 degrees of operation in tight areas
- Chrome Vanadium steel and special heat treatments provides thin walls for strength
- Meeting ANSI standard



W67104S	4PCS 72 TEETH RATCHETING STAR WRENCH SET
	SIZE : E6 X E8, E10 X E12, E14 X E18, E20 X E24



W32206S	6PCS 45° OFFSET RING WRENCH SET(SAE)
	Contents : 1/4"x5/16", 3/8"x7/16", 1/2"x9/16", 5/8"x11/16", 3/4"x7/8", 15/16"x1" Packing : POUCH + COLOR BOX 12SETS/CTN/17KGS/18KGS/1.2'

JONNESWAY

JONNESWAY

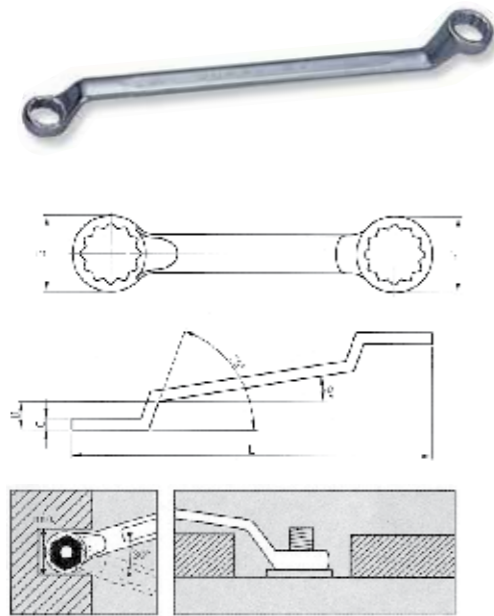

W23	75° OFFSET RING WRENCH(MM)
	• CHROME VANADIUM • HEAT TREATED • CHROME PLATED • DIN 838 STANDARD

ITEM NO.	SIZE (mm)	BxB1 (mm)	C (mm)	D (mm)	L (mm)	WEIGHT (g)	INNER PC/BOX	OUTER PC/CTN
W230607	6 x 7	10.7 x 12.2	5.7	6.3	168	43	12	240
W230809	8 x 9	13.6 x 15.1	6.7	7.0	183	62	12	180
W230810	8 x 10	13.6 x 15.1	6.7	7.0	183	62	12	180
W231011	10 x 11	16.6 x 18.0	7.4	7.7	198	88	12	180
W231012	10 x 12	16.6 x 18.0	7.4	7.7	198	88	12	180
W231113	11 x 13	19.5 x 20.9	8.1	8.4	217	131	12	120
W231213	12 x 13	19.5 x 20.9	8.1	8.4	217	131	12	120
W231214	12 x 14	19.5 x 20.9	8.1	8.4	217	131	12	120
W231415	14 x 15	22.4 x 23.7	8.8	9.1	239	152	12	120
W231617	16 x 17	25.3 x 26.7	9.5	9.8	260	189	12	48
W231719	17 x 19	28.2 x 29.7	10.1	10.4	292	240	12	48
W231819	18 x 19	28.2 x 29.7	10.1	10.4	292	240	9	48
W231921	19 x 21	31.1 x 34.0	10.9	11.4	318	330	9	48
W231922	19 x 22	31.1 x 34.0	10.9	11.4	318	330	9	48
W232022	20 x 22	31.1 x 34.0	10.9	11.4	318	330	9	48
W232123	21 x 23	32.6 x 35.5	11.2	11.6	327	362	9	48
W232427	24 x 27	36.9 x 41.0	12.4	13.4	329	436	9	48
W233032	30 x 32	45.5 x 48.5	14.4	15.2	362	600	9	24

OFFSET 12-POINT WRENCH

- Offset and thin-wall rings provide better entry to recessed fasteners.
- 30° increments

JONNESWAY

JONNESWAY



W23108S	8PCS 75° OFFSET RING WRENCH SET(MM)
	Contents : 6x7, 8x9, 10x11, 12x13, 14x15, 16x17, 18x19, 20x22MM Packing : POUCH + COLOR BOX 12SETS/CTN/18KGS/20KGS/1.2'

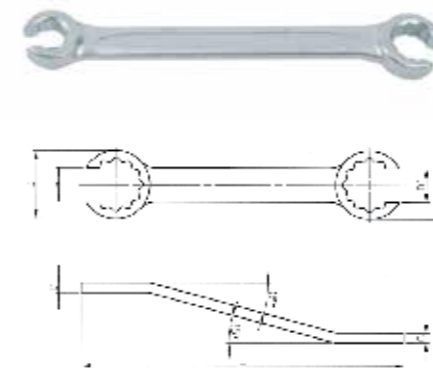

W24	FLARE NUT WRENCH(MM)
	• CHROME VANADIUM • HEAT TREATED • CHROME PLATED • DIN 3118 STANDARD

ITEM NO.	SIZE (mm)	BxB1 (mm)	C (mm)	DxD1 (mm)	L (mm)	WEIGHT (g)	PACKING	
							INNER PC/BOX	OUTER PC/CTN
W240809	8 x 9	18.0 x 20.0	7.0 x 8.5	6.0 x 7.0	145	50.0	12	360
W240810	8 x 10	18.0 x 20.0	7.0 x 8.5	6.0 x 7.0	145	50.0	12	360
W241011	10 x 11	20.0 x 22.0	8.5 x 9.0	7.0 x 8.5	152	65.0	12	240
W241012	10 x 12	20.0 x 22.0	8.5 x 9.0	7.0 x 9.0	152	65.0	12	240
W241213	12 x 13	22.0 x 26.0	9.0 x 10.5	8.5 x 10.0	165	110.0	12	240
W241214	12 x 14	24.0 x 28.0	9.5 x 11.0	9.0 x 11.0	178	150.0	12	180
W241314	13 x 14	24.0 x 28.0	9.5 x 11.0	9.0 x 11.0	178	150.0	12	180
W241417	14 x 17	28.0 x 30.0	11.0 x 12.0	11.0 x 14.0	196	135.0	12	120
W241617	16 x 17	28.0 x 30.0	11.0 x 12.0	11.0 x 14.0	196	135.0	12	120
W241719	17 x 19	30.0 x 32.0	12.0 x 14.0	14.0 x 15.0	210	180.0	12	96
W241922	19 x 22	32.0 x 38.0	14.0 x 16.0	15.0 x 17.0	233	260.0	6	60
W242123	21 x 23	38.0 x 42.0	16.0 x 17.0	17.0 x 18.0	252	290.0	6	48
W242224	22 x 24	38.0 x 42.0	16.0 x 17.0	17.0 x 18.0	252	290.0	6	48
W242427	24 x 27	42.0 x 46.0	17.0 x 18.0	18.0 x 20.0	265	350.0	6	48
W243032	30 x 32	50.0 x 52.0	21.0 x 23.0	22.0 x 24.0	285	480.0	3	24
W243236	32 x 36	52.0 x 60.0	23.0 x 25.0	24.0 x 25.0	315	780.0	3	24
W243641	36 x 41	60.0 x 67.0	25.0 x 27.0	25.0 x 32.0	350	1200.0	3	24

• 8~14mm : 6pt, 15~41mm : 12pt



W24106S	6PCS FLARE NUT WRENCH SET(MM)
	Contents : 8x9, 10x11, 10x12, 13x14, 16x17, 17x19MM Packing : POUCH + COLOR BOX 12SETS/CTN/7.5KGS/11.5KGS/1.2'

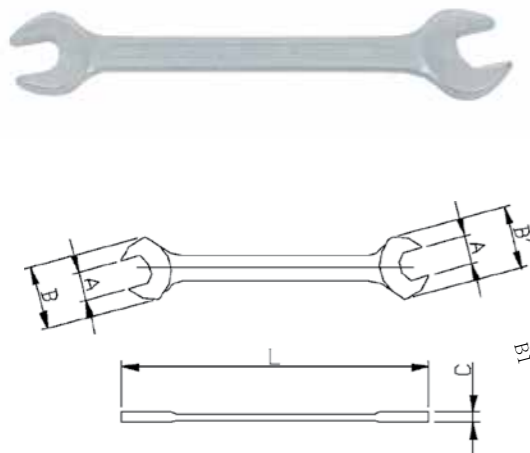

W25 OPEN END WRENCH(MM)
 • CHROME VANADIUM • HEAT TREATED
 • CHROME PLATED
 • DIN 3110 STANDARD

ITEM NO.	SIZE (mm)	BxB1 (mm)	C (mm)	L (mm)	WEIGHT (g)	INNER PC/BOX	OUTER PC/CTN
W250607	6 x 7	15.5 x 18.0	3.7	123	17.0	12	360
W250809	8 x 9	20.4 x 22.7	4.0	140	31.0	12	360
W250810	8 x 10	20.4 x 22.7	4.0	140	31.0	12	360
W251011	10 x 11	24.9 x 27.1	5.0	156	43.0	12	240
W251012	10 x 12	24.9 x 27.1	5.0	156	43.0	12	240
W251113	11 x 13	29.2 x 31.2	5.5	172	60.0	12	240
W251213	12 x 13	29.2 x 31.2	5.5	172	60.0	12	240
W251214	12 x 14	31.3 x 33.3	5.5	180	75.0	12	180
W251415	14 x 15	33.3 x 35.3	5.9	190	81.0	12	180
W251417	14 x 17	33.3 x 38.9	6.1	195	95.0	12	180
W251617	16 x 17	37.1 x 38.9	6.3	204	109.0	12	120
W251819	18 x 19	40.9 x 42.8	6.7	221	155.0	12	120
W251922	19 x 22	44.8 x 48.8	7.1	237	220.0	12	96
W252022	20 x 22	44.8 x 48.8	9.1	237	220.0	12	96
W252123	21 x 23	46.8 x 50.8	7.7	247	230	12	48
W252224	22 x 24	46.8 x 50.8	7.7	247	230	6	48
W252427	24 x 27	52.8 x 59.1	8.1	263	275	6	48
W253032	30 x 32	65.4 x 69.8	9.0	298	440	6	36

JONNESWAY



W25108S 8PCS OPEN END WRENCH SET(MM)
 Contents : 6x7, 8x9, 10x11, 12x13, 14x15, 16x17, 18x19, 20x22MM
 PACKING : POUCH + COLOR BOX
 12SETS/CTN/12KGS/16KGS/0.95'

JONNESWAY



W29 STAR WRENCH
 • CHROME VANADIUM
 • MAT FINISHED

ITEM NO.	SIZE	L (mm)	WEIGHT (g)	PACKING	
				INNER PC/BOX	OUTER PC/CTN
W290608	E6 x E8	112	14	12	360
W290711	E7 x E11	125	30	12	360
W291012	E10 x E12	140	30	12	360
W291418	E14 x E18	180	70	12	240
W291622	E16 x E22	200	124	12	120
W292024	E20 x E24	224	144	12	96

W71 45° COMBINATION WRENCH (12PT)
 • CHROME VANADIUM
 • MAT FINISHED

ITEM NO.	SIZE (mm)	L (mm)	B (mm)	C (mm)	D (mm)	F (mm)	H (mm)	T (mm)
W71106	6 1/4	90	13.4	95	4.0	4.2	7.0	2.4
W71107	7 -	95	14.9	107	4.0	4.6	7.5	2.8
W71108	8 5/16	105	17.5	125	4.6	5.2	8.3	3.0
W71109	9 -	115	20.6	135	5.0	5.8	9.5	3.0
W71110	10 3/8	125	21.5	147	5.2	6.42	10.5	3.2
W71111	11 7/16	140	23.2	166	5.5	7	11.5	3.4
W71112	12 -	155	25.5	18	5.7	7.6	12.5	3.6
W71113	13 1/2	165	28.2	192	6.0	8	13.5	3.8
W71114	14 -	180	29.1	202	6.2	8.3	14.0	4.0
W71115	15 9/16	190	33.4	214	6.4	9.4	15.0	4.2
W71116	16 -	205	34.6	235	6.7	9.7	15.3	4.5
W71117	17 11/16	215	37.8	25	7.2	10.5	17.0	4.8
W71118	18 -	230	37.1	257	7.3	11	17.5	5.0
W71119	19 3/4	240	40.2	277	8.0	12	18.0	6.0
W71120	20 -	255	42.5	285	8.3	13	18.8	6.2
W71121	21 13/16	265	45	32	8.5	13.4	21.5	6.4
W71122	22 -	280	47.4	33	8.7	13.8	20.5	6.6
W71123	23 -	290	49	35	9.0	14.2	22.5	7.0
W71124	24 -	305	51	36	9.7	14.6	22.6	7.4
W71125	25 (26)	330	56.6	38	10.0	16.2	24.8	7.8
W71127	27 -	345	58.5	40	10.4	17.5	25.2	8.2
W71128	28 -	365	60	42	10.8	18	25.2	8.5
W71130	30 (29)	380	63.8	44	11.0	19.2	26.0	8.7
W71132	32 -	405	68	365	11.6	20.5	27.5	8.7

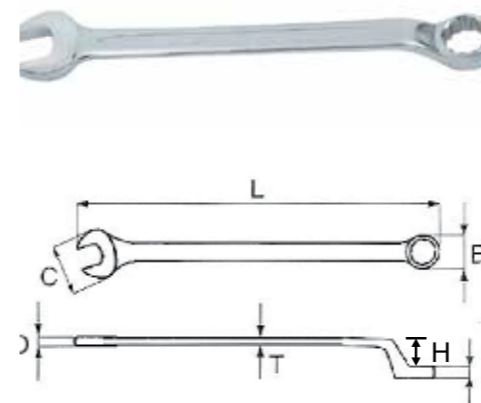



W26112S	12PCS COMBINATION WRENCH SET(MM) Contents : 8, 9, 10, 11, 12, 13, 14, 15, 16, 17, 19, 22MM Packing : POUCH + COLOR BOX 12SETS/CTN/13.5KGS/17.5KGS/1.2'
W26114S	14PCS COMBINATION WRENCH SET(MM) Contents : 10, 11, 12, 13, 14, 16, 17, 19, 21, 22, 24, 27, 30, 32MM Packing : POUCH + COLOR BOX 6SETS/CTN/17KGS/19.5KGS/1'
W26116S	16PCS COMBINATION WRENCH SET(MM) Contents : 6, 7, 8, 9, 10, 11, 12, 13, 14, 15, 16, 17, 18, 19, 22, 24MM Packing : METAL CASE + COLOR BOX 6SETS/CTN/9.5KGS/20KGS/1.13'
W26126S	26PCS COMBINATION WRENCH SET(MM) Contents : 6, 7, 8, 9, 10, 11, 12, 13, 14, 15, 16, 17, 18, 19, 20, 21, 22, 23, 24, 25, 26, 27, 28, 29, 30, 32MM Packing : POUCH 12SETS/CTN/11KGS/14.5KGS/1.2'

JONNESWAY



W264108PRS	8PCS COMBINATION WRENCH SET-LONG PATTERN TYPE(MM) Contents : 10, 11, 12, 13, 14, 15, 17, 19MM Packing : PLASTIC HOLDER 12SETS/CTN/11KGS/14.5KGS/1.2'
W26411PRS	11PCS COMBINATION WRENCH SET(MM) Contents : 7, 8, 9, 10, 11, 12, 13, 14, 15, 17, 19MM Packing : POUCH + COLOR BOX 12SETS/CTN/12KGS/16.5KGS/0.9'
W26411SA	11PCS COMBINATION WRENCH SET-LONG PATTERN TYPE(SAE) Contents : 3/8", 7/16", 1/2", 9/16", 5/8", 11/16", 3/4", 13/16", 7/8", 15/16", 1" Packing : POUCH + COLOR BOX 8SETS/CTN/20KGS/21KGS/1.1'
W26414S	14PCS COMBINATION WRENCH SET(SAE) Contents : 3/8", 7/16", 1/2", 9/16", 5/8", 11/16", 3/4", 13/16", 7/8", 15/16", 1", 1-1/16", 1-1/8", 1-1/4" Packing : POUCH + COLOR BOX 4SETS/CTN/24KGS/24.5KGS/0.9'

JONNESWAY



W53	MIDGET COMBINATION WRENCH						
ITEM NO.	SIZE (inch)	L (mm)	B (mm)	D (mm)	S1 (mm)	S2 (mm)	WEIGHT (g)
W53216	5/8"	121	35.0	23.8	6.6	10.1	84.5
W53217	11/16"	127	37.5	25.0	6.8	10.8	107.1
W53219	3/4"	137	41.3	28.0	7.8	11.9	142.5

- Torque As 1.2 Times As ANSI Standard
- Chrome Vanadium Steel
- Mirror Polished
- Short Shank For Operating Easily In Combined Space
- 15° Offset Ring End Of Design For Easy Operation

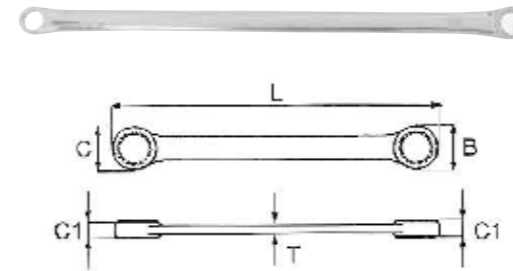

JONNESWAY

W61	EXTRA-LONG DOUBLE RING END WRENCH							
	• CHROME-MOLYBDFNUM				• MIRROR FINI SHED			
ITEM NO.	SIZE	L (mm)	C (mm)	B (mm)	C1 (mm)	B1 (mm)	T (mm)	WT (mm)
W610810	8X10	235	15.1	12.6	8.5	7.5	4.4	78
W611011	10X11	395	19.1	16.2	9.1	8.4	4.6	124
W611012	10X12	395	19.1	16.2	9.1	8.4	4.6	124
W611214	12X14	330	26.5	22.2	14.5	12.8	5.8	200
W611315	13X15	370	26.5	22.2	14.6	12.9	5.8	308
W611417	14X17	370	26.5	22.	14.6	12.9	5.8	308
W611618	16X18	405	29.3	26.2	16.0	15	7.8	432
W611719	17X19	405	29.3	26.6	16.0	15	7.8	432
W612224	22X24	435	35.0	33.0	18.6	17.3	9.2	573

W61106S	6PCS EXTRA-LONG DOUBLE RING WRENCH SET							
CONTENTS:								
W61	10X11, 12X14, 13X15, 16X18, 17X19, 22X24MM							
PACKING	POUCH							



JONNESWAY

W65	DOUBLE ENDED RING WRENCH (STARTER)							
	• CHROME VANADIUM				• MAT FINISHED			
ITEM NO.	SIZE	L (mm)	C (mm)	B (mm)	C1 (mm)	B1 (mm)	T (mm)	WT (mm)
W6510810	8X10	137	15.6	14.3	6.5	6.2	4.0	45
W6511011	10X11	141	15.6	18.2	6.6	6.5	4.2	56
W6511012	10X12	141	15.6	18.2	6.6	6.5	4.2	56
W6511113	11X13	166	18.2	21.0	8.2	8.0	4.9	93
W6511315	13X15	190	22.0	25.0	9.2	8.2	5.3	134
W6511417	14X17	190	22.0	25.0	9.2	8.2	5.3	134
W6511618	16X18	220	25.5	28.0	9.6	8.8	5.6	190
W6511922	19X22	256	28.6	32.5	11.1	10.1	6.6	240





W43		DOUBLE FLEXIBLE SOCKET WRENCH				
• CR-V • MAT FINISHED						
ITEM NO.	SIZE (mm)	L (mm)	WEIGHT (g)	PACKING		
				INNER PC/BOX	OUTER PC/CTN	
W43A0607	6 x 7	180	72	12	240	
W43A0809	8 x 9	180	78	12	240	
W43A1011	10 x 11	202	115	12	192	
W43A1012	10 x 12	202	125	12	192	
W43A1213	12 x 13	222	155	12	96	
W43A1214	12 x 14	223	170	12	96	
W43A1415	14 x 15	245	245	12	96	
W43A1417	14 x 17	245	245	12	96	
W43A1617	16 x 17	260	330	12	48	
W43A1719	17 x 19	260	330	12	48	
W43A1819	18 x 19	280	414	12	48	
W43A2022	20 x 22	305	595	12	24	

JONNESWAY



W43A106S		6PCS DOUBLE FLEXIBLE SOCKET WRENCH SET	
• CR-V • MAT FINISHED			
Contents : 8X9, 10X11, 12X13, 14X15, 16X17, 18X19			
Packing : BLOWING CASE + COLOR BOX			
6SETS/CTN/9KGS/10KGS/1.08'			

JONNESWAY

W43B		FLEXIBLE SOCKET WRENCH				
• CR-V • MAT FINISHED						
ITEM NO.	SIZE (mm)	L (mm)	WEIGHT (g)	PACKING		
				INNER PC/BOX	OUTER PC/CTN	
W43B108	8	170	65	12	240	
W43B109	9	170	65	12	240	
W43B110	10	180	76	12	200	
W43B111	11	190	105	12	150	
W43B112	12	195	114	12	150	
W43B113	13	218	140	12	150	
W43B114	14	230	186	12	100	
W43B115	15	230	195	12	100	
W43B116	16	235	234	12	72	
W43B117	17	235	234	12	72	
W43B118	18	255	307	12	72	
W43B119	19	255	307	12	72	



Auto-release **ON** : Operating Instruction

W27AR		AUTO-RELEASE ADJUSTABLE WRENCH	
ITEM NO	SIZE	MAX. JAW OPENING NOT LESS THAN (MM)	
W27AR8	8"(200)	26.9	
W27AR10	10"(250)	34	

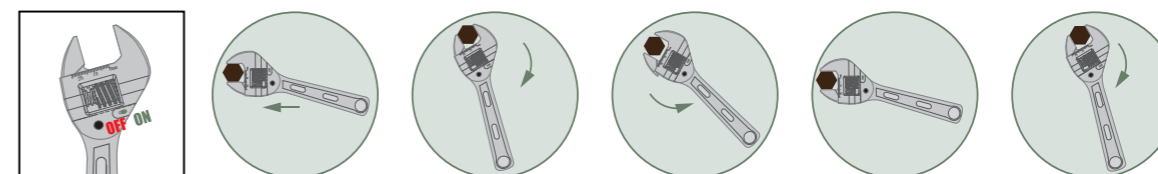

JONNESWAY

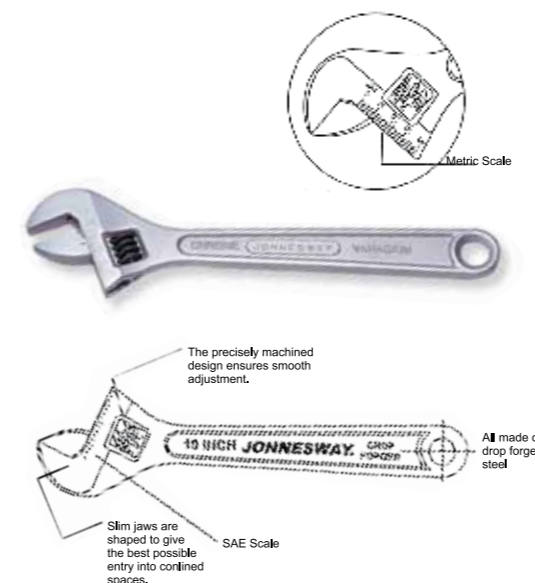

JONNESWAY

W27AS		ADJUSTABLE ANGLE WRENCH							
• MAT FINISHED • DIN 3117 ANSI/ASME B107.8M									
ITEM NO.	SIZE INCH (mm)	MAX. JAW OPENING NOT LESS THAN (mm)	USING RANGE FOR		OVERALL LENGTH (mm)	LOAD BENDING TEST MIN. (cm-kgf)	WEIGHT (g)	PACKING	
			Metric	SAE				INNER PC/BOX	OUTER PC/CTN
W27AS4	4" (100)	13	M1-M8	W1/8-W1/4	105-110	714	50-57	6	120
W27AS6	6" (150)	20	M1-M12	W1/8-W7/16	155-162	1674	120-127	6	120
W27AS8	8" (200)	24	M1-M16	W1/8-W1/2	203-211	3061	240-254	6	60
W27AS10	10" (250)	29	M1-M18	W1/8-W5/8	250-260	5204	410-425	6	36
W27AS12	12" (300)	34	M1-M22	W1/8-W3/4	300-310	8776	630-690	6	24
W27AS15	15" (380)	43	M1-M27	W1/8-W1	375-390	17347	1180-1240	4	16
W27AS18	18" (450)	53	M1-M33	W1/8-W1-1/4	450-470	23469	1900-1960	6	12

ANTI-SLIP JAW



W27AT		TIGER'S PAW ADJUSTABLE WRENCH				
ITEM NO.	SIZE (inch/mm)	STANDARD JAW OPENING WIDTH (mm)	MAX. JAW OPENING NOT LESS THAN (mm)	WEIGHT (g)	PACKING	
					INNER PC/BOX	OUTER PC/CTN
W27AT4	4" (100)	13	17.0	0.06	6	120
W27AT6	6" (150)	19	23.9	0.122	6	120
W27AT8	8" (200)	24	28.6	0.242	6	60
W27AT10	10" (250)	29	32.8	0.397	6	48
W27AT12	12" (300)	34	38.1	0.609	6	24
W27AT15	15" (375)	43	51.0	1.14	1	16

- Ensuring security in use.
- Meeting DIN/ANSI Standard.
- Button at the end of the handle increases the strength over 200 kgf, which is twice as the original design.
- Ergonomic handle design allows proper usage and durability of the tool.
- Wider jaw opening 18%-25%
- Less weight with increased torsional rigidity.
- Anti-slip opening end



W28HD HAWK PIPE WRENCH (DUCTILE IRON)

- Self adjusting wrench head automatically adjusts to different pipe sizes up to 1-1/2" diameter.
- Ergonomic design allows one-handed fitting, adjusting, torquing and removal.
- Spring loaded jaw enables fast ratchet action.
- The patented 3-point jaw design provides an extra-strong grip for increased torque.
- Convenient thumb trigger provides easy, quick release.
- Material : DUCTILE IRON

DUCTILE IRON

ITEM NO.	Overall Length (mm)	Capacity (mm)	Max Open Width (mm)
W28HD08	(200) 8"	(10.16 - 21.8) 0.4" - 0.86"	(21.8) 0.86"
W28HD10	(250) 10"	(12.7 - 30) 0.5" - 1.15"	(30) 1.15"
W28HD12	(300) 12"	(15.87 - 35.3) 0.625" - 1.39"	(35.3) 1.39"
W28HD14	(350) 14"	(17.78 - 50.8) 0.7" - 2"	(50.8) 2"

EASY OPERATION



- Push the Thumb Trigger Downwards to Open the Jaw



- Patented 3 Points Jaw Design Provides an Extra-Strong Grip for Increase Torque



- 3 Points Jaw Design Fit Around Pipe & Release the Thumb Trigger to Operate



- To Release the Pipe, Push the Thumb Trigger Downward



W2848R

JONNESWAY

W28 DROP FORGED PIPE WRENCH
 • BODY : CAST IRON
 • JAW : CHROME MOLYBDENUM

ITEM NO.	SIZE		JAW CAPACITY (PIPE SIZE I.D.)		WEIGHT (kg)	PACKING	
	inch	mm	inch	mm		INNER PC/BOX	OUTER PC/CTN
W2808	8"	200	1"	25.4	0.36	6	36
W2810	10"	250	1-1/2"	38.1	0.65	6	36
W2812	12"	300	2"	50.8	0.95	6	24
W2814	14"	350	2"	50.8	1.25	6	12
W2818	18"	450	2-1/2"	63.5	2	6	12
W2824	24"	600	3"	76.2	3.7	2	6
W2836	36"	900	5"	127	7	1	2
W2848R	48"	1200	6"	152.4	14	1	1

W28A ALUMINUM ALLOY PIPE WRENCH
 • BODY : ALUMINUM ALLOY
 • JAW : CHROME MOLYBDENUM DROP FORGED

ITEM NO.	SIZE		JAW CAPACITY (PIPE SIZE I.D.)		WEIGHT (kg)	PACKING	
	inch	mm	inch	mm		INNER PC/BOX	OUTER PC/CTN
W28A14	14"	350	2"	50.8	0.95	6	24
W28A18	18"	450	2-1/2"	63.5	1.55	2	12
W28A24	24"	600	3"	76.2	2.45	2	8
W28A36	36"	900	5"	127	4.75	1	4
W28A48	48"	1200	6"	152.4	9	1	2



- Aluminum alloy body
- CR-MO drop forged Jaw
- Pipe size on hook jaw for quick adjustment to proper width.
- Hardened forged steel jaw provides maximum strength at stress point.
- Replaceable heel jaw supported by high strength shoulder.
- Deep milled teeth hardened to stay sharp.
- Balanced for proper weight distribution.
- Heavy duty spring maintains preset jaw adjustment, aids in positive pipe engagement.
- Large knurl and power threads provide fast jaw adjustment.

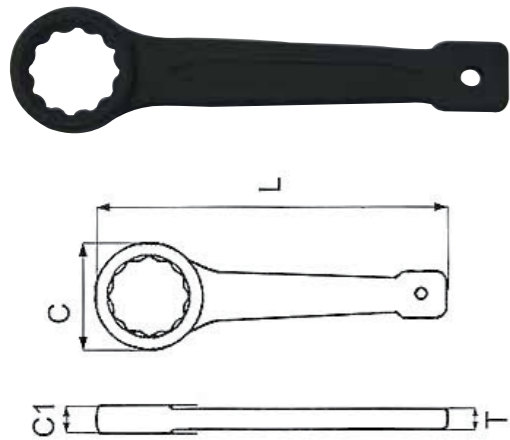

W72	SLUGGING WRENCH	
	• CHROME-MOLYBDENUM	• MAT FINISHED
	• MANGANESE PHOSPHATING	

ITEM NO.	SIZE	L (mm)	C (mm)	C1 (mm)	T (mm)	WT (mm)
W72122	22	163	42.0	15.5	8.0	242
W72123	23	163	42.0	15.5	8.0	242
W72124	24	163	42.0	15.5	8.0	242
W72125	25	163	42.0	15.5	8.0	242
W72126	26	180	46.0	16.5	10.0	340
W72127	27	180	46.0	16.5	10.0	340
W72128	28	180	46.0	16.5	10.0	340
W72129	29	190	52.0	17.5	10.0	416
W72130	30	190	52.0	17.5	10.0	416
W72132	32	190	52.0	17.5	10.0	416
W72133	33	190	52.0	17.5	10.0	416
W72134	34	205	58.0	18.5	11.0	518
W72135	35	205	58.0	18.5	11.0	518
W72136	36	205	58.0	18.5	11.0	518
W72138	38	205	58.0	18.5	11.0	518
W72140	40	230	66.0	20.5	12.0	735
W72141	41	230	66.0	20.5	12.0	735
W72142	42	230	66.0	20.5	12.0	735
W72143	43	230	66.074.0	20.5	12.0	930
W72144	44	240	74.0	22.5	14.0	930
W72145	45	240	74.0	22.5	14.0	930
W72146	46	240	74.0	22.5	14.0	930
W72147	47	240	74.0	22.5	14.0	1162
W72148	48	255	80.0	24.5	16.0	1162
W72150	50	255	80.0	24.5	16.0	1162
W72152	52	255	80.0	24.5	16.0	1362
W72155	55	270	86.0	25.5	17.0	1650
W72160	60	280	96.0	26.5	18.0	1650
W72165	65	280	96.0	26.5	18.0	1650
W72170	70	335	108.0	32.0	23.0	3530
W72175	75	335	108.0	32.0	23.0	3530
W72180	80	365	121.0	36.0	23.0	5200
W72185	85	365	121.0	36.0	23.0	5200
W72190	90	400	141.0	40.0	24.0	7500
W72195	95	400	141.0	40.0	24.0	7500
W721100	100	435	164.0	37.0	28.0	10200
W721105	105	435	164.0	37.0	28.0	10200



New Patent in Worldwide !!

SUPER TECH SERIES

- The revolutionary “SUPER TECH” ONE DRIVE FIT ALL” solution for all fastening needs.
- The SUPER TECH system fits Metric 6pt. Metric 12pt, SAE 6pt, SAE 12PT, E-TORX, Spline, Square & 50% rounded off nuts bolts.
- The nuts’/ bolts’ point of contact are evenly distributed onto larger surface areas during application, thus distributing pressure instead connecting to several sharp point, so as the nuts / bolts will not be damaged easily.
- Manufactured from high quality materials including improved Chrome Vanadium Steel (Cr-V4), Molybdenum and Tungsten which extends the life ability 10 times the DIN standard.
- Torque exceeds double the normal DIN standard.
- The SUPER TECH system can be applied to a wide variety of markets-Automotive, Industrial, Retail & Hardware.

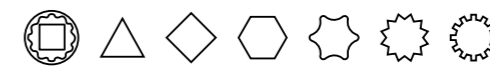

FIXING CONVERSION TABLES

SIZE	METRIC	SAE	STAR	SIZE	METRIC	SAE	STAR
3.2	3.2	1/8"	E4	16	16	5/8"	E20
4	4	5/32"	E5	17	17	21/32"	
4.5	4.5			18	18	11/16"	E22
5	5	3/16"	E6	19	19	3/4"	E24
5.5	5.5	7/32"	E7	20	20	25/32"	
6	6		E8	21	21	13/16"	E26
1/4"		1/4"	E8	22	22	7/8"	E28
7	7	9/32"		23	23	29/32"	E28
8	8	5/16"	E10	24	24	15/16"	E30
9	9	11/32"	E11	25	25	31/32"	E32
10	10	3/8"	E12	26	26	1"	E32
11	11	7/16"	E14	27	27	1-1/16"	E34
12	12	15/32"		28	28	1-3/32"	E36
13	13	1/2"	E16	29	29	1-1/8"	E36
14	14	9/16"	E18	30	30	1-3/16"	E38
15	15	19/32"		32	32	1-1/4"	E40



New Patent in Worldwide !!

SUPER TECH SERIES

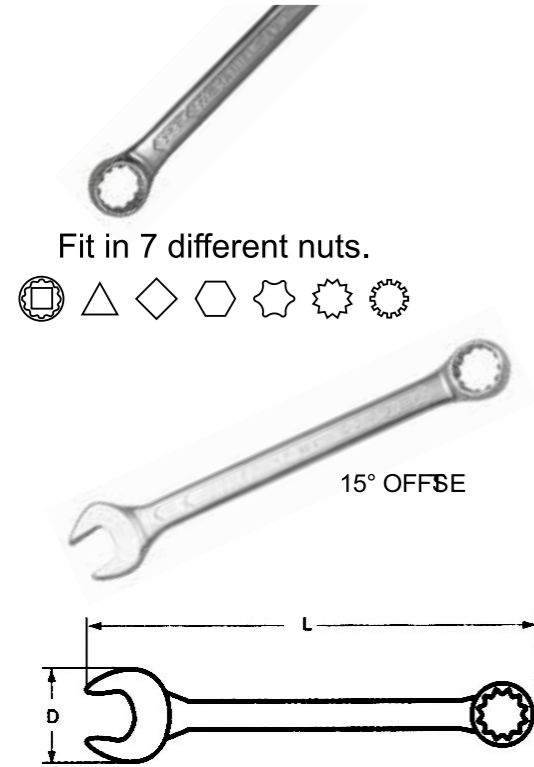

Fit in 7 different nuts.

15° OFFSE

- Material: CR-V
- SATIN Finish

W84 SUPER TECH COMBINATION WRENCH (CR-V)

ITEM NO.	OPEN END SIZE	RING END SIZE			L (mm)	WEIGHT (g)
		METRIC	SAE	STAR		
W84106	6	6	-	E8	105	21
W84107	7	7	9/32"	-	115	23
W84108	8	8	5/16"	E10	125	26
W84109	9	9	11/32"	E11	135	29
W84110	10	10	3/8"	E12	145	39
W84111	11	11	7/16"	E14	155	52
W84112	12	12	15/32"	-	165	64
W84113	13	13	1/2"	E16	175	68
W84114	14	14	9/16"	E18	185	87
W84115	15	15	19/32"	-	195	102
W84116	16	16	5/8"	E20	205	114
W84117	17	17	21/32"	-	215	135
W84118	18	18	11/16"	E22	225	154
W84119	19	19	3/4"	E24	235	178
W84120	20	20	25/32"	-	245	192
W84121	21	21	13/16"	E26	255	216
W84122	22	22	7/8"	E28	265	237
W84123	23	23	29/32"	E28	275	282
W84124	24	24	15/16"	E30	285	309
W84125	25	25	31/32"	E32	295	314
W84126	26	26	1"	E32	305	344
W84127	27	27	1-1/16"	E34	315	369
W84128	28	28	1-3/32"	E36	325	412
W84129	29	29	1-1/8"	E36	335	441
W84130	30	30	1-3/16"	E38	345	493
W84132	32	32	1-1/4"	E40	365	464

New Patent in Worldwide !!

SUPER TECH SERIES



Fit in 7 different nuts.

- FINISH : SATIN FINISH
- STRAIGHT
- Material:CR-V

W86112S 12PCS SUPER TECH 72 TEETH REVERSIBLE RATCHETING COMBINATION WRENCH SET

CONTENTS:

- 12PCS - SUPER TECH 72 TEETH RATCHETING COMBINATION WRENCH : 8, 9, 10, 11, 12, 13, 14, 15, 16, 17, 18, 19mm
- FINISH : SATIN FINISH

SIZE	METRIC	SAE	STAR	SIZE	METRIC	SAE	STAR
8	8	5/16"	E10	14	14	9/16"	E18
9	9	11/32"	E11	15	15	19/32"	-
10	10	3/8"	E12	16	16	5/8"	E20
11	11	7/16"	E14	17	17	21/32"	-
12	12	15/32"	-	18	18	11/16"	E22
13	13	1/2"	E16	19	19	3/4"	E24

JONNESWAY



W84108S 8PCS SUPER TECH COMBINATION WRENCH SET

CONTENTS:

- 8PCS - SUPER TECH COMBINATION WRENCH : 8, 10, 11, 12, 13, 14, 17 , 19mm
- FINISH : SATIN FINISH



New Patent in Worldwide !!

New Patent in Worldwide !!

SUPER TECH SERIES

SUPER TECH SERIES

S68H2 1/4" SUPER TECH SOCKET

6.35 MM (1/4")

ITEM NO.	SIZE			D(MM)	L(MM)	W.(G)
	METRIC	SAE	STAR			
S68H2103	3.2	1/8"	E4	13	25	12
S68H2104	4	5/32"	E5	13	25	12
S68H21045	4.5	-	-	13	25	12
S68H2105	5	3/16"	E6	13	25	12
S68H21055	5.5	7/32"	E7	13	25	13
S68H2106	6	-	E8	13	25	13
S68H21065	-	1/4"	E8	13	25	13
S68H2107	7	9/32"	-	13	25	13
S68H2108	8	5/16"	E10	13	25	13
S68H2109	9	11/32"	E11	14	25	17
S68H2110	10	3/8"	E12	15	25	19
S68H2111	11	7/16"	E14	17	25	21
S68H2112	12	15/32"	-	18	25	24
S68H2113	13	1/2"	E16	19	25	28
S68H2114	14	9/16"	E18	21	25	25

Fit in 7 different nuts.



- The revolutionary SUPER TECH is the ONE DRIVE FIT ALL solution for all fastening needs.
- The SUPER TECH system fits Metric 6pt., Metric 12pt., SAE 6pt., SAE 12pt., E-Trox, Spline, Square & 50% Rounded off nuts & bolts.
- The nuts / bolts' point of contact are evenly distributed onto larger surface; areas during application, thus distributing pressure instead of connectin to several sharp point so the nuts / bolts will not be damaged easily.
- Manufactured from high quality materials including improved Chrome Vanadium Steel(Cr-V4), Molybdenum and Tugstgen which extends the life ability 10 times the DIN standard.
- Torque exceeds double the normal DIN standard.
- The SUPER TECH system can be applied to a wide variety of markets - Automotive, Industrial, Retail & Hardware.
- Patent worldwide:
Taiwan, U.S.A. Germany, European Union, Japan, India, China,

S68H3 3/8" SUPER TECH SOCKET

9.5 MM (3/8")

ITEM NO.	SIZE			D(MM)	L(MM)	W.(G)
	METRIC	SAE	STAR			
S68H3106	6	-	E8	18	28	23
S68H31065	-	1/4"	E8	18	28	23
S68H3107	7	9/32"	-	18	28	23
S68H3108	8	5/16"	E10	18	28	23
S68H3109	9	11/32"	E11	18	28	24
S68H3110	10	3/8"	E12	18	28	24
S68H3111	11	7/16"	E14	18	28	27
S68H3112	12	15/32"	-	18	28	28
S68H3113	13	1/2"	E16	19	28	29
S68H3114	14	9/16"	E18	21	28	29
S68H3115	15	19/32"	-	22	28	34
S68H3116	16	5/8"	E20	23	28	38
S68H3117	17	21/32"	-	25	30	50
S68H3118	18	11/16"	E22	26	30	54
S68H3119	19	3/4"	E24	27	30	61
S68H3120	20	25/32"	-	28	30	59
S68H3121	21	13/16"	E26	29	30	64
S68H3122	22	7/8"	E28	31	32	79
S68H3123	23	29/32"	E28	32	32	87
S68H3124	24	15/16"	E30	33	32	89

Fit in 7 different nuts.

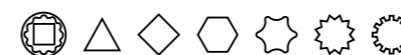

- The revolutionary SUPER TECH is the ONE DRIVE FIT ALL solution for all fastening needs.
- The SUPER TECH system fits Metric 6pt., Metric 12pt., SAE 6pt., SAE 12pt., E-Trox, Spline, Square & 50% Rounded off nuts & bolts.
- The nuts / bolts' point of contact are evenly distributed onto larger surface; areas during application, thus distributing pressure instead of connectin to several sharp point so the nuts / bolts will not be damaged easily.
- Manufactured from high quality materials including improved Chrome Vanadium Steel(Cr-V4), Molybdenum and Tugstgen which extends the life ability 10 times the DIN standard.
- Torque exceeds double the normal DIN standard.
- The SUPER TECH system can be applied to a wide variety of markets - Automotive, Industrial, Retail & Hardware.
- Patent worldwide:
Taiwan, U.S.A. Germany, European Union, Japan, India, China,

S68H41 1/2" SUPER TECH SOCKET

12.7 MM (1/2")

ITEM NO.	SIZE			D(MM)	L(MM)	W.(G)
	METRIC	SAE	STAR			
S68H4108	8	5/16"	E10	23	38	48
S68H4109	9	11/32"	E11	23	38	51
S68H4110	10	3/8"	E12	23	38	53
S68H4111	11	7/16"	E14	23	38	54
S68H4112	12	15/32"	-	23	38	55
S68H4113	13	1/2"	E16	23	38	56
S68H4114	14	9/16"	E18	23	38	59
S68H4115	15	19/32"	-	23	38	63
S68H4116	16	5/8"	E20	24	38	70
S68H4117	17	21/32"	-	25	38	74
S68H4118	18	11/16"	E22	26	38	75
S68H4119	19	3/4"	E24	27	38	70
S68H4120	20	25/32"	-	29	40	86
S68H4121	21	13/16"	E26	30	40	95
S68H4122	22	7/8"	E28	31	40	96
S68H4123	23	29/32"	E28	32	40	107
S68H4124	24	15/16"	E30	33.5	42	122
S68H4125	25	31/32"	E32	33.5	42	135
S68H4126	26	1"	E32	36	42	152
S68H4127	27	1-1/16"	E34	38	44	173
S68H4128	28	1-3/32"	E36	39	44	151
S68H4129	29	1-1/8"	E36	40	44	186
S68H4130	30	1-3/16"	E38	41	45	193
S68H4132	32	1-1/4"	E40	44	45	225

New Patent in Worldwide !!

SUPER TECH SERIES



S68H4127S 27PCS 1/2"DR. SUPER TECH SOCKET SET

CONTENTS:

- 1PC - 1/2"DR. SLIDING T-BAR
- 1PC - 1/2"DR. UNIVERSAL JOINT
- 2PCS - 1/2"DR. EXTENSION BAR : 125, 250mm
- 2PCS - 1/2"DR. SPARK PLUG SOCKET : 16, 21mm
- 1PC - 1/2"DR. RATCHET HANDLE 36 TEETH: R2904
- 20PCS - 1/2"DR. SUPER TECH SOCKET : 8, 9, 10, 11, 12, 13, 14, 15, 16, 17, 18, 19, 20, 21, 22, 23, 24, 27, 30, 32mm
- FINISH : SATIN FINISH

SIZE	METRIC	SAE	STAR	SIZE	METRIC	SAE	STAR
8	8	5/16"	E10	18	18	11/16"	E22
9	9	11/32"	E11	19	19	3/4"	E24
10	10	3/8"	E12	20	20	25/32"	-
11	11	7/16"	E14	21	21	13/16"	E26
12	12	15/32"	-	22	22	7/8"	E28
13	13	1/2"	E16	23	23	29/32"	E28
14	14	9/16"	E18	24	24	15/16"	E30
15	15	19/32"	-	27	27	1-1/16"	E34
16	16	5/8"	E20	30	30	1-3/16"	E38
17	17	21/32"	-	32	32	1-1/4"	E40

JONNESWAY

S68H5234111S 111PCS 1/4", 3/8" & 1/2"DR. SUPER TECH SOCKET SET

CONTENTS:

- 1PC - 1/4"DR. RATCHET HANDLE 48 TEETH : R3702
- 1PC - 1/4"DR. UNIVERSAL JOINT
- 1PC - 1/4"DR. SPINNER HANDLE
- 2PCS - 1/4"DR. EXTENSION BAR : 50, 150mm
- 13PCS - 1/4"DR. SUPER TECH SOCKET : 3.2, 4, 4.5, 5, 5.5, 6, 7, 8, 9, 10, 11, 12, 13mm
- 21PCS - 1/4"DR. SOCKET BITS : \oplus 1, 2, 3 \oplus 1, 2, 3 \ominus 4, 5.5, 7 \ominus 3, 4, 5, 6, 7, 8
- T10, T15, T20, T25, T30, T40
- 1PC - 3/8"DR. UNIVERSAL JOINT
- 1PC - 3/8"DR. RATCHET HANDLE 48 TEETH : R3703
- 2PCS - 3/8"DR. EXTENSION BAR : 75, 150mm
- 2PCS - 3/8"DR. SPARK PLUG SOCKET : 14, 18mm
- 11PCS - 3/8"DR. SUPER TECH SOCKET : 9, 10, 11, 12, 13, 14, 15, 16, 17, 18, 19mm
- 1PC - 1/2"DR. UNIVERSAL JOINT
- 1PC - 1/2"DR. RATCHET HANDLE 48 TEETH : R3704
- 2PCS - 1/2"DR. EXTENSION BAR : 125, 250mm
- 2PCS - 1/2"DR. SPARK PLUG SOCKET : 16, 21mm
- 14PCS - 1/2"DR. SUPER TECH SOCKET : 14, 15, 16, 17, 18, 19, 20, 21, 22, 23, 24, 27, 30, 32mm
- 12PCS - SUPER TECH COMBINATION WRENCH : 8, 9, 10, 11, 12, 13, 14, 15, 16, 17, 18, 19mm
- 3PCS - T-M HEAD : 3/8"(F) X 1/4"(M) & 3/8"(F) X 1/2"(M) & 1/2"(F) X 3/8"(M)
- 2PCS - COUPLER : 3/8"DR. * 5/16" HEX & 1/2"DR. * 5/16" HEX
- 15PCS - 5/16" BITS : \oplus 3, 4 \ominus 8, 10, 12 \ominus 8, 10, 12, 14 \oplus 3, 4 \oplus T40, T45, T50, T55
- 3PCS - HEX KEY WRENCH : 1.5, 2.0, 2.5mm
- FINISH : SATIN FINISH

SIZE	METRIC	SAE	STAR	SIZE	METRIC	SAE	STAR
3.2	3.2	1/8"	E4	15	15	19/32"	-
4	4	5/32"	E5	16	16	5/8"	E20
4.5	4.5	-	-	17	17	21/32"	-
5	5	3/16"	E6	18	18	11/16"	E22
5.5	5.5	7/32"	E7	19	19	3/4"	E24
6	6	-	E8	20	20	25/32"	-
7	7	9/32"	-	21	21	13/16"	E26
8	8	5/16"	E10	22	22	7/8"	E28
9	9	11/32"	E11	23	23	29/32"	E28
10	10	3/8"	E12	24	24	15/16"	E30
11	11	7/16"	E14	25	25	31/32"	E32
12	12	15/32"	-	27	27	1-1/16"	E34
13	13	1/2"	E16	30	30	1-3/16"	E38
14	14	9/16"	E18	32	32	1-1/4"	E40



SOCKET SERIES

- Professional Quality: ANSI / DIN Standards
- Super Torque: 1.5 times over DIN & 1.3 times over ANSI Standards
- Manual Sockets & Impact Sockets
- Regular Sockets & Deep Sockets
- Metric Size & SAE Size
- Flank Point with Maxi-Drive: to Protect Nuts and Create Higher Torque



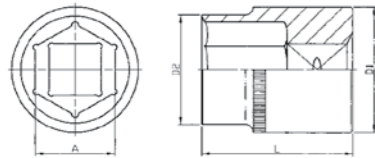

S04H2 **1/4" DR. 6PT FLANK SOCKETS**
 • CHROME VANADIUM STEEL
 • SEMI MAT FINISHED

ITEM NO.	S (mm)	D2 (mm)	D1 (mm)	T (mm)	L (mm)	WEIGHT (g)	PACKING	
							INNER PC/BOX	OU PC/CTN
S04H2104	4	6.8	11.8	7	25	9.5	60	1080
S04H21045	4.5	7.3	11.8	9	25	9.9	60	1080
S04H2105	5	8.0	11.8	9	25	9.9	60	1080
S04H21055	5.5	8.6	11.8	9	25	10.1	60	1080
S04H2106	6	9.2	11.8	9	25	10.4	60	1080
S04H2107	7	10.5	11.8	9	25	11.2	60	1080
S04H2108	8	11.7	11.4	9	25	10.2	60	1080
S04H2109	9	12.7	11.6	9	25	11.7	60	1080
S04H2110	10	13.7	12.8	9	25	13.1	60	1080
S04H2111	11	15.7	14.4	9	25	18	60	1080
S04H2112	12	16.6	13.7	9	25	22.4	60	720
S04H2113	13	17.6	13.9	9	25	23.5	60	720

- Professional Quality
- The Hardness & The Torque Conform To International Standard
- DIN 3124

JONNESWAY

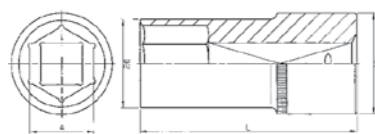

S04HD2 **1/4" DR. 6PT FLANK DEEP SOCKETS**
 • CHROME VANADIUM STEEL
 • SEMI MAT FINISHED

ITEM NO.	S (mm)	D2 (mm)	D1 (mm)	T (mm)	L (mm)	WEIGHT (g)	PACKING	
							INNER PC/BOX	OUTER PC/CTN
S04HD2104	4	8.0	12.0	20	50	20	30	540
S04HD21045	4.5	8.0	12.0	20	50	20	30	540
S04HD2105	5	8.0	12.0	20	50	20	30	540
S04HD21055	5.5	8.6	12.0	20	50	20	30	540
S04HD2106	6	9.2	12.0	20	50	20	30	540
S04HD2107	7	10.5	12.0	20	50	22	30	540
S04HD2108	8	12.0	11.5	20	50	22	30	540
S04HD2109	9	13.1	12.4	20	50	28	30	540
S04HD2110	10	14.4	13.3	20	50	34	30	540
S04HD2111	11	15.9	14.8	20	50	56	30	540
S04HD2112	12	17.0	15.8	20	50	60	30	360
S04HD2113	13	17.8	16.8	20	50	66	30	360

- Professional Quality
- The Hardness & The Torque Conform To International Standard
- DIN 3124

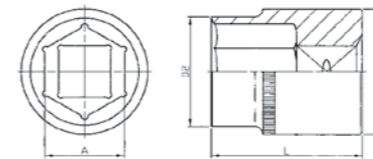

S04H3 **3/8" DR. 6PT FLANK SOCKETS**
 • CHROME VANADIUM STEEL
 • SEMI MAT FINISHED

ITEM NO.	S (mm)	D2 (mm)	D1 (mm)	T (mm)	L (mm)	WEIGHT (g)	PACKING	
							INNER PC/BOX	OUTER PC/CTN
S04H3106	6	9.6	16.8	6	28	24	40	360
S04H3107	7	10.7	16.8	6	28	24	40	360
S04H3108	8	12.0	16.8	8	28	24	40	360
S04H3109	9	13.3	16.8	8	28	24	40	360
S04H3110	10	14.4	16.8	8	28	24	40	360
S04H3111	11	15.8	16.8	8	28	24	40	360
S04H3112	12	16.8	16.0	9	28	24	40	360
S04H3113	13	19.0	18.0	9	28	24	40	360
S04H3114	14	19.7	18.8	10	28	30	40	360
S04H3115	15	20.8	19.8	10	28	40	40	360
S04H3116	16	22.0	20.8	10	28	40	40	360
S04H3117	17	23.8	22.0	10	28	56	40	360
S04H3118	18	25.7	24.1	12	28	58	40	160
S04H3119	19	25.7	24.1	12	28	60	40	160
S04H3120	20	27.6	25.0	12	32	70	40	160
S04H3121	21	27.6	25.0	14	32	76	40	160
S04H3122	22	29.6	27.8	14	32	76	40	160
S04H3124	24	31.0	29.8	16	32	112	40	160

- Professional Quality
- The Hardness & The Torque Conform To International Standard
- Inch Size Available
- DIN 3124

JONNESWAY

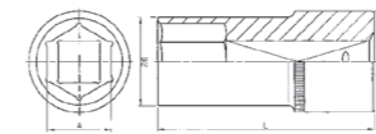

S04HD3 **3/8" DR. 6PT FLANK DEEP SOCKETS**
 • CHROME VANADIUM STEEL
 • SEMI MAT FINISHED

ITEM NO.	S (mm)	D2 (mm)	D1 (mm)	T (mm)	L (mm)	WEIGHT (g)	PACKING	
							INNER PC/BOX	OUTER PC/CTN
S04HD3106	6	9.8	16.8	7	63	43	20	180
S04HD3107	7	10.8	16.8	7	63	45	20	180
S04HD3108	8	12.0	16.8	8	63	50	20	180
S04HD3109	9	13.3	16.8	9	63	60	20	180
S04HD3110	10	14.4	17.0	9	63	60	20	180
S04HD3111	11	15.8	17.0	10	63	60	20	180
S04HD3112	12	17.7	17.0	12	63	66	20	180
S04HD3113	13	19.0	18.0	12	63	76	20	180
S04HD3114	14	19.7	18.8	15	63	80	20	180
S04HD3115	15	20.8	19.8	15	63	90	20	180
S04HD3116	16	22.0	20.8	15	63	92	20	180
S04HD3117	17	23.8	22.8	15	63	110	20	180
S04HD3118	18	26.0	23.8	18	63	125	20	80
S04HD3119	19	26.0	23.8	18	63	130	20	80
S04HD3120	20	27.8	24.8	18	63	140	20	80
S04HD3121	21	28.0	25.8	18	63	150	20	80
S04HD3122	22	30.0	27.8	21	63	168	20	80
S04HD3124	24	32.0	28.0	21	63	193	20	80

- Professional Quality
- International Standard For The Hardness And Torque
- Inch Size Available
- DIN 3124



THESE SOCKETS SHOULD NEVER BE USED ON POWER DRIVE OR IMPACT WRENCHES!



THESE SOCKETS SHOULD NEVER BE USED ON POWER DRIVE OR IMPACT WRENCHES!

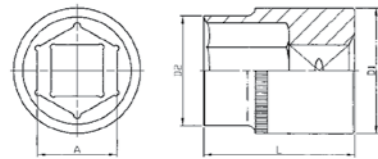

- Professional Quality
- International Standard For Hardness And Torque
- DIN 3124

S04H4 1/2" DR. 6PT FLANK SOCKETS

- CHROME VANADIUM STEEL
- SEMI MAT FINISHED

ITEM NO.	S (mm)	D2 (mm)	D1 (mm)	T (mm)	L (mm)	WEIGHT (g)	PACKING	
							INNER PC/BOX	OUTER PC/CTN
S04H4108	8	13.8	21.8	8	38	50	20	300
S04H4109	9	14.3	21.8	8	38	50	20	300
S04H4110	10	15.4	21.8	9	38	50	20	300
S04H4111	11	16.7	21.8	9	38	50	20	300
S04H4112	12	18.0	21.8	9	38	53	20	300
S04H4113	13	19.0	21.8	10	38	55	20	300
S04H4114	14	20.3	22.0	12	38	55	20	300
S04H4115	15	21.3	22.0	12	38	55	20	300
S04H4116	16	23.3	22.0	12	38	60	20	300
S04H4117	17	23.8	23.0	12	38	67	20	160
S04H4118	18	24.8	23.5	12	38	71	20	160
S04H4119	19	27.0	24.0	12	38	84	20	160
S04H4120	20	28.0	24.0	12	38	87	20	160
S04H4121	21	29.0	24.0	12	38	90	20	160
S04H4122	22	30.0	28.0	14	38	98	20	160
S04H4123	23	30.7	28.0	14	38	115	20	120
S04H4124	24	31.8	28.0	16	38	125	20	120
S04H4125	25	33.8	28.0	16	38	150	20	120
S04H4126	26	34.0	30.0	16	42	155	20	120
S04H4127	27	35.7	28.0	18	42	165	20	120
S04H4128	28	38.0	30.0	20	42	165	20	80
S04H4129	29	38.0	32.0	20	42	170	20	80
S04H4130	30	39.8	34.0	20	42	200	20	80
S04H4132	32	42.0	36.0	22	42	240	20	80
S04H4134	34	45	40	24	48	280	6	54
S04H4136	36	48	42	24	48	333	5	45

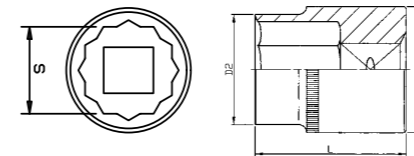

- Professional Quality
- International Standard For Hardness And Torque
- DIN 3124

S04H49 1/2" DR. 12PT SOCKETS(MM)

- CHROME VANADIUM STEEL
- SEMI MAT FINISHED

ITEM NO.	S (mm)	D2 (mm)	D1 (mm)	T (mm)	L (mm)	WEIGHT (g)	PACKING	
							INNER PC/BOX	OUTER PC/CTN
S04H4908	8	13.8	21.8	8	38	50	20	300
S04H4909	9	14.3	21.8	8	38	50	20	300
S04H4910	10	15.4	21.8	9	38	50	20	300
S04H4911	11	16.7	21.8	9	38	50	20	300
S04H4912	12	18.0	21.8	9	38	53	20	300
S04H4913	13	19.0	21.8	10	38	55	20	300
S04H4914	14	20.3	22.0	12	38	55	20	300
S04H4915	15	21.3	22.0	12	38	55	20	300
S04H4916	16	23.3	22.0	12	38	60	20	300
S04H4917	17	23.8	23.0	12	38	67	20	160
S04H4918	18	24.8	23.5	12	38	71	20	160
S04H4919	19	27.0	24.0	12	38	84	20	160
S04H4920	20	28.0	24.0	12	38	87	20	160
S04H4921	21	29.0	24.0	12	38	90	20	160
S04H4922	22	30.0	28.0	14	38	98	20	160
S04H4923	23	30.7	28.0	14	38	115	20	120
S04H4924	24	31.8	28.0	16	38	125	20	120
S04H4925	25	33.8	28.0	16	38	150	20	120
S04H4926	26	34.0	30.0	16	42	155	20	120
S04H4927	27	35.7	28.0	18	42	165	20	120
S04H4928	28	38.0	30.0	20	42	165	20	80
S04H4929	29	38.0	32.0	20	42	170	20	80
S04H4930	30	39.8	34.0	20	42	200	20	80
S04H4932	32	42.0	38.0	22	42	240	20	80

JONNESWAY

JONNESWAY

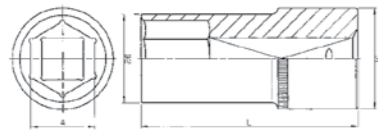

- Professional Quality
- International Standard For Hardness And Torque
- DIN 3124

S04HD4 1/2" DR. 6PT FLANK DEEP SOCKETS

- CHROME VANADIUM STEEL
- SEMI MAT FINISHED

ITEM NO.	S (mm)	D2 (mm)	D1 (mm)	T (mm)	L (mm)	WEIGHT (g)	PACKING	
							INNER PC/BOX	OUTER PC/CTN
S04HD4108	8	12.7	21.8	9	76	114	10	150
S04HD4109	9	14.3	21.8	9	76	114	10	150
S04HD4110	10	15.4	21.8	10	76	114	10	150
S04HD4111	11	16.7	21.8	12	76	114	10	150
S04HD4112	12	18.0	21.8	13	76	114	10	150
S04HD4113	13	19.0	21.8	14	76	118	10	150
S04HD4114	14	20.3	22.0	15	76	130	10	150
S04HD4115	15	21.3	22.0	16	76	136	10	150
S04HD4116	16	23.0	22.0	17	76	138	10	150
S04HD4117	17	23.8	23.0	18	76	144	10	80
S04HD4118	18	24.8	23.0	19	76	150	10	80
S04HD4119	19	25.8	24.0	20	76	178	10	80
S04HD4120	20	28.0	24.0	21	76	180	10	80
S04HD4121	21	29.0	24.0	23	76	190	10	80
S04HD4122	22	30.0	26.0	27	76	240	10	80
S04HD4123	23	31.8	28.0	27	76	248	10	60
S04HD4124	24	31.8	28.0	27	76	250	10	60
S04HD4125	25	33.8	28.0	27	76	265	10	60
S04HD4126	26	33.8	28.0	27	76	282	10	60
S04HD4127	27	35.7	28.0	28	76	320	10	60
S04HD4128	28	38.0	30.0	28	76	300	10	40
S04HD4130	30	39.8	34.0	34	76	324	10	40

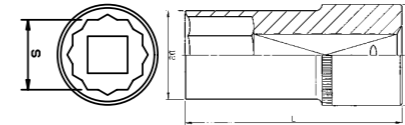

- Professional Quality
- International Standard For Hardness And Torque
- DIN 3124

S04HD47 1/2" DR. 12PT FLANK DEEP SOCKETS

- CHROME VANADIUM STEEL
- SEMI MAT FINISHED

ITEM NO.	S (mm)	D2 (mm)	D1 (mm)	L (mm)	WEIGHT (g)	PACKING	
						INNER PC/BOX	OUTER PC/CTN
S04HD4710	10	15	21.8	76	114	10	150
S04HD4711	11	16.3	21.8	76	114	10	150
S04HD4712	12	17.6	21.8	76	114	10	150
S04HD4713	13	18.8	21.8	76	118	10	150
S04HD4714	14	20.4	21.8	76	130	10	150
S04HD4715	15	22	21	76	136	10	150
S04HD4716	16	22	21	76	138	10	150
S04HD4717	17	24	22	76	144	10	80
S04HD4718	18	26	23	76	150	10	80
S04HD4719	19	26	23	76	178	10	80
S04HD4720	20	28	24	76	180	10	80
S04HD4721	21	28	24	76	190	10	80
S04HD4722	22	30	26	76	240	10	80
S04HD4723	23	32	28	76	248	10	80
S04HD4724	24	32	28	76	250	10	60

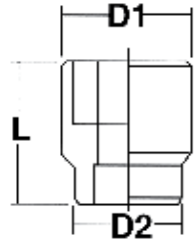

S04H61		3/4" DR. 6PT FLANK SOCKETS				
<ul style="list-style-type: none"> • CHROME VANADIUM STEEL • SEMI MAT FINISHED • DIN 3124 						

ITEM NO.	S (mm)	L (mm)	D1 (mm)	D2 (mm)	WEIGHT (g)	PACKING	
						INNER PC/BOX	OUTER PC/CTN
S04H6119	19	49.5	30	36	220	25	100
S04H6121	21	49.5	32	36	220	25	100
S04H6122	22	49.5	33	36	220	25	100
S04H6123	23	49.5	34	36	220	25	100
S04H6124	24	49.5	35	36	220	25	100
S04H6125	25	50	36	36	220	25	100
S04H6126	26	50	37	36	220	25	100
S04H6127	27	52	38	36	220	25	100
S04H6128	28	52	39	36	220	25	100
S04H6129	29	53	40	38	237	25	100
S04H6130	30	54	42	38	262	25	75
S04H6132	32	56	44	38	281	25	75
S04H6133	33	56	46	38	312	25	75
S04H6134	34	58	46	38	312	25	50
S04H6135	35	58	48	42	358	25	50
S04H6136	36	58	50	42	400	25	50
S04H6138	38	60	52	45	450	25	50
S04H6141	41	64	56	45	537	10	30
S04H6146	46	68	62	48	650	10	30
S04H6150	50	72	68	48	783	10	30

JONNESWAY

S04H64		3/4" DR. 12PT FLANK SOCKETS				
<ul style="list-style-type: none"> • CHROME VANADIUM STEEL • SEMI MAT FINISHED • ANSI / ASME B107.1 						

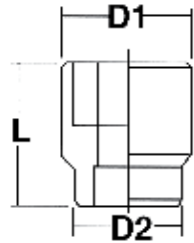

ITEM NO.	S (size)	L (mm)	D1 (mm)	D2 (mm)	WEIGHT (g)
S04H6419	3/4"	49.5	30	36	220
S04H6421	13/16"	49.5	32	36	220
S04H6422	7/8"	49.5	33	36	220
S04H6424	15/16"	49.5	35	36	220
S04H6426	1"	50	37	36	220
S04H6427	1-1/16"	52	38	36	220
S04H6429	1-1/8"	53	40	38	237
S04H6430	1-3/16"	54	42	38	262
S04H6432	1-1/4"	56	44	38	281
S04H6433	1-5/16"	56	46	38	312
S04H6435	1-3/8"	58	48	42	358
S04H6436	1-7/16"	58	50	42	400
S04H6438	1-1/2"	60	52	45	450
S04H6441	1-5/8"	64	56	45	537
S04H6444	1-3/4"	64	56	45	537
S04H6446	1-13/16"	68	62	48	650
S04H6447	1-7/8"	68	62	48	650
S04H6450	2"	72	68	48	783
S04H6456	2-1/4"	76	75	48	1000



- Professional Quality
- International Standard For Hardness And Torque

JONNESWAY

S06H2		1/4" DR. STAR SOCKETS						
<ul style="list-style-type: none"> • CHROME VANADIUM STEEL • SEMI MAT FINISHED • DIN 3120 								

ITEM NO.	A (size)	S (mm)	D1 (mm)	D2 (mm)	L1 (mm)	L2 (mm)	WEIGHT (g)	PACKING	
								INNER PC/BOX	OUTER PC/CTN
S06H204	E4	6.350	12	6.2	25	11	10	50	1000
S06H205	E5	6.350	12	7.2	25	11	10	50	1000
S06H206	E6	6.350	12	8.2	25	11	11	50	1000
S06H207	E7	6.350	12	9.0	25	11	11	50	1000
S06H208	E8	6.350	12	10.3	25	11	12	50	1000

S06H3		3/8" DR. STAR SOCKETS						
<ul style="list-style-type: none"> • CHROME VANADIUM STEEL • SEMI MAT FINISHED • DIN 3120 								

ITEM NO.	A (size)	S (mm)	D1 (mm)	D2 (mm)	L1 (mm)	L2 (mm)	WEIGHT (g)	PACKING	
								INNER PC/BOX	OUTER PC/CTN
S06H308	E8	9.525	17	11.2	28	12	24	40	800
S06H310	E10	9.525	17	13.2	28	12	25	40	800
S06H311	E11	9.525	17	13.8	28	12	25	40	800
S06H312	E12	9.525	17	14.8	28	12	26	40	800
S06H314	E14	9.525	18	16.8	28	12	33	40	800
S06H316	E16	9.525	20	18.8	28	12	43	40	480
S06H318	E18	9.525	22	20.8	28	12	53	20	300
S06H320	E20	9.525	24	22.8	28	12	61	20	300



- Professional Quality
- International Standard For Hardness And Torque

JONNESWAY

S06H4		1/2" DR. STAR SOCKETS						
<ul style="list-style-type: none"> • CHROME VANADIUM STEEL • SEMI MAT FINISHED • DIN 3120 								

ITEM NO.	A (size)	S (mm)	D1 (mm)	D2 (mm)	L1 (mm)	L2 (mm)	WEIGHT (g)	PACKING	
								INNER PC/BOX	OUTER PC/CTN
S06H410	E10	12.700	22	13.2	38	17	50	20	300
S06H411	E11	12.700	22	13.9	38	17	50	20	300
S06H412	E12	12.700	22	15.0	38	17	53	20	300
S06H414	E14	12.700	22	16.7	38	17	53	20	300
S06H416	E16	12.700	22	18.8	38	17	55	20	300
S06H418	E18	12.700	22	20.8	38	17	80	20	160
S06H420	E20	12.700	22	23.0	38	17	90	20	160
S06H422	E22	12.700	22	25.0	38	17	93	20	160
S06H424	E24	12.700	22	27.0	38	17	111	20	160



- Professional Quality
- International Standard For Hardness And Torque
- DIN 3120

THESE SOCKETS SHOULD NEVER BE USED ON POWER DRIVE OR IMPACT WRENCHES!

THESE SOCKETS SHOULD NEVER BE USED ON POWER DRIVE OR IMPACT WRENCHES!

SOCKETS SERIES

SOCKETS SERIES

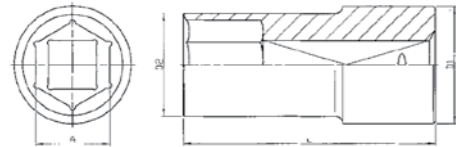

ITEM NO.		A (size)	D1 (mm)	D2 (mm)	L (mm)	WEIGHT (g)	PACKING	
							INNER PC/BOX	OUTER PC/CTN
S05HD2		1/4" DR. 6PT DEEP SOCKETS (MAXI-DRIVE) • CHROME VANADIUM STEEL • POLISH-FINISHED • ANSI/ASME B107.1						
S05HD2105		5	12.0	8.0	50	18	30	540
S05HD2106		6	12.0	9.2	50	18	30	540
S05HD2107		7	12.0	10.5	50	20	30	540
S05HD2108		8	12.0	12.0	50	20	30	540
S05HD2109		9	13.1	13.1	50	20	30	540
S05HD2110		10	14.4	14.4	50	20	30	540
S05HD2111		11	15.9	15.9	50	25	30	540
S05HD2112		12	17.0	17.0	50	35	30	360
S05HD2113		13	17.8	17.8	50	50	30	360

JONNESWAY

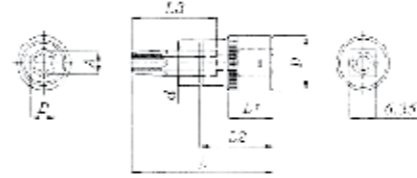

JONNESWAY

ITEM NO.		A (size)	L3 (mm)	B (mm)	L (mm)	D (mm)	d (mm)	L1 (mm)	L2 (mm)	WEIGHT (g)	PACKING	
											INNER PC/BOX	OUTER PC/CTN
S07H2		1/4" DR. STAR BIT SOCKETS • CHROME VANADIUM STEEL • SEMI MAT FINISHED • DIN 3120										
S07H206		T6	25	6.3	37	12	10.8	13	19	14	40	240
S07H207		T7	25	6.3	37	12	10.8	13	19	14	40	240
S07H208		T8	25	6.3	37	12	10.8	13	19	14	40	240
S07H209		T9	25	6.3	37	12	10.8	13	19	14	40	240
S07H210		T10	25	6.3	37	12	10.8	13	19	14	40	240
S07H215		T15	25	6.3	37	12	10.8	13	19	14	40	240
S07H220		T20	25	6.3	37	12	10.8	13	19	14	40	240
S07H225		T25	25	6.3	37	12	10.8	13	19	14	40	240
S07H227		T27	25	6.3	37	12	10.8	13	19	14	40	240
S07H230		T30	25	6.3	37	12	10.8	13	19	14	40	240
S07H240		T40	25	6.3	37	12	10.8	13	19	16	40	240

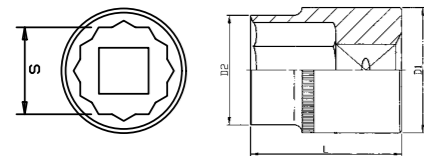

ITEM NO.		A (size)	D1 (mm)	D2 (mm)	L (mm)	WEIGHT (g)	PACKING	
							INNER PC/BOX	OUTER PC/CTN
S05H3		3/8" DR. 12PT SOCKETS (MAXI-DRIVE) • CHROME VANADIUM STEEL • POLISH - FINISHED • ANSI/ASME B107.1						
S05H3808		8	16.8	12.0	28	20	40	360
S05H3809		9	16.8	13.3	28	20	40	360
S05H3810		10	17.0	14.4	28	20	40	360
S05H3811		11	17.7	15.8	28	25	40	360
S05H3812		12	17.7	17.7	28	25	40	360
S05H3813		13	19.0	19.0	28	35	40	360
S05H3814		14	19.7	19.7	28	30	40	360
S05H3815		15	20.8	20.8	28	40	40	360
S05H3816		16	22.0	22.0	28	40	40	360
S05H3817		17	23.8	23.8	30	50	40	360
S05H3819		19	26.0	26.0	30	70	40	160

JONNESWAY

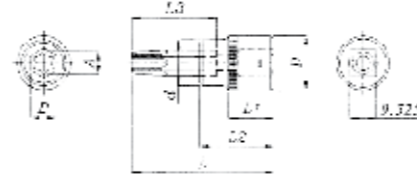

JONNESWAY

ITEM NO.		A (size)	L3 (mm)	B (mm)	L (mm)	D (mm)	d (mm)	L1 (mm)	L2 (mm)	WEIGHT (g)	PACKING	
											INNER PC/BOX	OUTER PC/CTN
S07H3		3/8" DR. STAR BIT SOCKETS • CHROME VANADIUM STEEL • SEMI MAT FINISHED • DIN 3120										
S07H310		T10	30	6.30	48	18	13.8	16.5	26	36	30	240
S07H315		T15	30	6.30	48	18	13.8	16.5	26	36	30	240
S07H320		T20	30	6.30	48	18	13.8	16.5	26	36	30	240
S07H325		T25	30	6.30	48	18	13.8	16.5	26	36	30	240
S07H327		T27	30	6.30	48	18	13.8	16.5	26	36	30	240
S07H330		T30	30	6.30	48	18	13.8	16.5	26	36	30	240
S07H340		T40	30	6.30	48	18	13.8	16.5	26	38	30	240
S07H345		T45	30	7.88	48	18	15.8	16.5	26	42	30	240
S07H350		T50	30	7.88	48	18	15.8	16.5	26	46	30	240
S07H355		T55	30	10.00	48	18	16.1	16.5	26	52	30	240
S07H360		T60	30	10.00	48	18	16.1	16.5	26	56	30	240

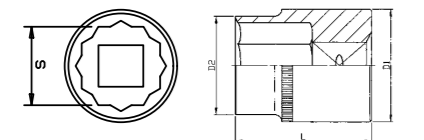

ITEM NO.		A (size)	D1 (mm)	D2 (mm)	L (mm)	WEIGHT (g)	PACKING	
							INNER PC/BOX	OUTER PC/CTN
S05H4		1/2" DR. 12PT SOCKETS (MAXI-DRIVE) • CHROME VANADIUM STEEL • POLISH - FINISHED • ANSI/ASME 107.1						
S05H4810		10	21.8	15.4	38	60	20	300
S05H4812		12	21.8	18.0	38	60	20	300
S05H4813		13	21.8	19.0	38	60	20	300
S05H4814		14	22.0	20.3	38	60	20	300
S05H4815		15	22.0	22.0	38	60	20	300
S05H4817		17	23.7	23.8	38	70	20	300
S05H4819		19	25.8	25.8	38	80	20	160
S05H4821		21	27.8	27.8	38	90	20	160

72

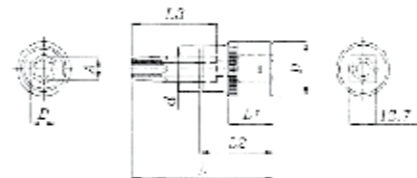

JONNESWAY

ITEM NO.		A (size)	L3 (mm)	B (mm)	L (mm)	D (mm)	d (mm)	L1 (mm)	L2 (mm)	WEIGHT (g)	PACKING	
											INNER PC/BOX	OUTER PC/CTN
S07H4		1/2" DR. STAR BIT SOCKETS • CHROME VANADIUM STEEL • SEMI MAT FINISHED • DIN 3120										
S07H420		T20	30	7.88	55	22	15	20	38	70	20	200
S07H425		T25	30	7.88	55	22	15	20	38	70	20	200
S07H427		T27	30	7.88	55	22	15	20	38	70	20	200
S07H430		T30	30	7.88	55	22	15	20	38	70	20	200
S07H440		T40	30	7.88	55	22	15	20	38	72	20	200
S07H445		T45	30	7.88	55	22	15	20	38	72	20	200
S07H450		T50	30	7.88	55	22	15	20	38	76	20	200
S07H455		T55	30	10	55	22	17	20	38	84	20	200
S07H460		T60	30	12	55	24	22	20	38	114	20	200
S07H470		T70	30	14	55	24	22	20	38	116	20	200
S07H4320		T20	75	7.88	100	24	15	20	38	88	20	200
S07H4325		T25	75	7.88	100	24	15	20	38	90	20	200
S07H4327		T27	75	7.88	100	24	15	20	38	90	20	200
S07H4330		T30	75	7.88	100	24	15	20	38	90	20	200
S07H4340		T40	75	7.88	100	24	15	20	38	92	20	200
S07H4345		T45	75	7.88	100	24	15	20	38	92	20	200
S07H4350		T50	75	7.88	100	24	15	20	38	92	20	200
S07H4355		T55	75	10	100	24	17	20	38	112	20	200
S07H4360		T60	75	14	100	24	22	20	38	172	20	200
S07H4370		T70	75	14	100	24	22	20	38	178	20	200

 THESE SOCKETS SHOULD NEVER BE USED ON POWER DRIVE OR IMPACT WRENCHES!

 THESE SOCKETS SHOULD NEVER BE USED ON POWER DRIVE OR IMPACT WRENCHES!

73

SOCKETS SERIES

SOCKETS SERIES

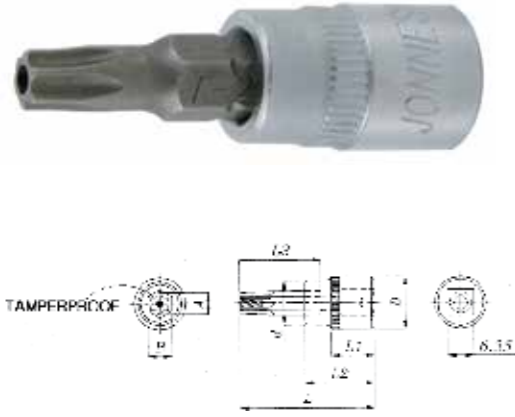

S08H2 1/4" DR. STAR BIT SOCKETS(TAMPERPROOF)
 • CHROME VANADIUM STEEL
 • SEMI MAT FINISHED
 • DIN 3120

ITEM NO.	A (size)	L3 (mm)	B (mm)	L (mm)	D (mm)	d (mm)	L1 (mm)	L2 (mm)	WEIGHT (g)	PACKING	
										INNER PC/BOX	OUTER PC/CTN
S08H206	T6	25	6.3	37	12	10.8	13	19	14	40	240
S08H207	T7	25	6.3	37	12	10.8	13	19	14	40	240
S08H208	T8	25	6.3	37	12	10.8	13	19	14	40	240
S08H209	T9	25	6.3	37	12	10.8	13	19	14	40	240
S08H210	T10	25	6.3	37	12	10.8	13	19	14	40	240
S08H215	T15	25	6.3	37	12	10.8	13	19	14	40	240
S08H220	T20	25	6.3	37	12	10.8	13	19	14	40	240
S08H225	T25	25	6.3	37	12	10.8	13	19	14	40	240
S08H227	T27	25	6.3	37	12	10.8	13	19	14	40	240
S08H230	T30	25	6.3	37	12	10.8	13	19	14	40	240
S08H240	T40	25	6.3	37	12	10.8	13	19	14	40	240

JONNESWAY

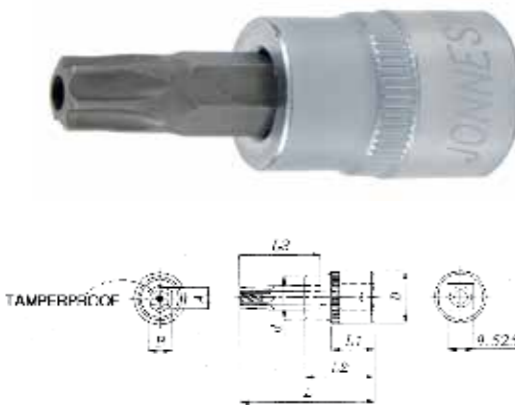

S08H3 3/8" DR. STAR BIT SOCKETS(TAMPERPROOF)
 • CHROME VANADIUM STEEL
 • SEMI MAT FINISHED
 • DIN 3120

ITEM NO.	A (size)	L3 (mm)	B (mm)	L (mm)	D (mm)	d (mm)	L1 (mm)	L2 (mm)	WEIGHT (g)	PACKING	
										INNER PC/BOX	OUTER PC/CTN
S08H310	T10	30	6.30	48	18	13.8	15.5	26.5	36	30	240
S08H315	T15	30	6.30	48	18	13.8	15.5	26.5	36	30	240
S08H320	T20	30	6.30	48	18	13.8	15.5	26.5	36	30	240
S08H325	T25	30	6.30	48	18	13.8	15.5	26.5	36	30	240
S08H327	T27	30	6.30	48	18	13.8	15.5	26.5	36	30	240
S08H330	T30	30	6.30	48	18	13.8	15.5	26.5	36	30	240
S08H340	T40	30	6.30	48	18	13.8	15.5	26.5	38	30	240

JONNESWAY



S08H4 1/2" DR. STAR BIT SOCKETS(TAMPERPROOF)
 • CHROME VANADIUM STEEL
 • SEMI MAT FINISHED
 • DIN 3120

ITEM NO.	A (size)	L3 (mm)	B (mm)	L (mm)	D (mm)	d (mm)	L1 (mm)	L2 (mm)	WEIGHT (g)	PACKING	
										INNER PC/BOX	OUTER PC/CTN
S08H420	T20	30	7.88	55	24	15	20	38	70	20	200
S08H425	T25	30	7.88	55	24	15	20	38	70	20	200
S08H427	T27	30	7.88	55	24	15	20	38	70	20	200
S08H430	T30	30	7.88	55	24	15	20	38	70	20	200
S08H440	T40	30	7.88	55	24	15	20	38	72	20	200
S08H445	T45	30	7.88	55	24	15	20	38	72	20	200
S08H450	T50	30	7.88	55	24	15	20	38	74	20	200
S08H455	T55	30	10	55	24	17	20	38	82	20	200
S08H460	T60	30	12	55	24	22	20	38	112	20	200
S08H470	T70	30	14	55	24	22	20	38	114	20	200



JONNESWAY



JONNESWAY



JONNESWAY

S09H2 1/4" DR. HEX BIT SOCKETS
 • CHROME VANADIUM STEEL
 • SEMI MAT FINISHED
 • DIN 7422

ITEM NO.	A (size)	L3 (mm)	B (mm)	L (mm)	D (mm)	d (mm)	L1 (mm)	L2 (mm)	WEIGHT (g)	PACKING	
										INNER PC/BOX	OUTER PC/CTN
S09H203	H3	25	6.3	37	12	10.8	13	19	14	40	240
S09H204	H4	25	6.3	37	12	10.8	13	19	14	40	240
S09H205	H5	25	6.3	37	12	10.8	13	19	14	40	240
S09H206	H6	25	6.3	37	12	10.8	13	19	16	40	240
S09H207	H7	25	6.3	37	12	10.8	13	19	16	40	240

S09H3 3/8" DR. HEX BIT SOCKETS
 • CHROME VANADIUM STEEL
 • SEMI MAT FINISHED
 • DIN 7422

ITEM NO.	A (size)	L3 (mm)	B (mm)	L (mm)	D (mm)	d (mm)	L1 (mm)	L2 (mm)	WEIGHT (g)	PACKING	
										INNER PC/BOX	OUTER PC/CTN
S09H303	H3	30	6.30	48	18	13.8	16.5	26	36	30	240
S09H304	H4	30	6.30	48	18	13.8	16.5	26	36	30	240
S09H305	H5	30	6.30	48	18	13.8	16.5	26	38	30	240
S09H3055	H5.5	30	6.30	48	18	13.8	16.5	26	38	30	240
S09H306	H6	30	6.30	48	18	13.8	16.5	26	38	30	240
S09H307	H7	30	7.88	48	18	15.8	16.5	26	44	30	240
S09H308	H8	30	7.88	48	18	15.8	16.5	26	44	30	240
S09H310	H10	30	10.0	48	18	16.1	16.5	26	52	30	240
S09H312	H12	30	10.0	48	18	16.1	16.5	26	62	30	240
S09H314	H14	30	10.0	48	18	16.1	16.5	26	78	30	240

S09H4 1/2" DR. HEX BIT SOCKETS
 • CHROME VANADIUM STEEL
 • SEMI MAT FINISHED
 • DIN 7422

ITEM NO.	A (size)	L3 (mm)	B (mm)	L (mm)	D (mm)	d (mm)	L1 (mm)	L2 (mm)	WEIGHT (g)	PACKING	
										INNER PC/BOX	OUTER PC/CTN
S09H404	H4	30	7.88	55	24	15	20	38	72	20	200
S09H405	H5	30	7.88	55	24	15	20	38	72	20	200
S09H406	H6	30	7.88	55	24	15	20	38	74	20	200
S09H407	H7	30	7.88	55	24	15	20	38	74	20	200
S09H408	H8	30	7.88	55	24	15	20	38	76	20	200
S09H410	H10	30	10	55	24	17.8	20	38	86	20	200
S09H412	H12	30	12	55	24	22	20	38	118	20	200
S09H414	H14	30	14	55	24	22	20	38	122	20	200
S09H416	H16	30	14	55	24	22	20	38	132	20	200
S09H4304	H4	75	7.88	100	24	15	20	38	92	20	200
S09H4305	H5	75	7.88	100	24	15	20	38	92	20	200
S09H4306	H6	75	7.88	100	24	15	20	38	92	20	200
S09H4307	H7	75	7.88	100	24	15	20	38	92	20	200
S09H4308	H8	75	7.88	100	24	15	20	38	96	20	200
S09H4310	H10	75	10	100	24	20.8	20	38	116	20	200
S09H4312	H12	75	14	100	24	22	20	38	176	20	200
S09H4314	H14	75	14	100	24	22	20	38	180	20	200
S09H4316	H16	75	14	100	24	22	20	38	222	20	200



THESE SOCKETS SHOULD NEVER BE USED ON POWER DRIVE OR IMPACT WRENCHES!



THESE SOCKETS SHOULD NEVER BE USED ON POWER DRIVE OR IMPACT WRENCHES!

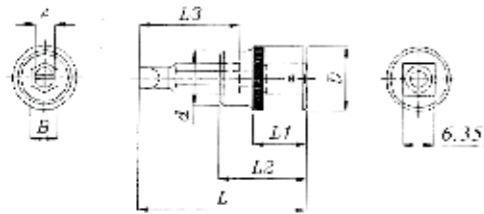

S10H2	1/4" DR. SLOTTED BIT SOCKETS										
	<ul style="list-style-type: none"> • CHROME VANADIUM STEEL • SEMI MAT FINISHED • DIN 5264 / 3120 										

ITEM NO.	A (size)	L3 (mm)	B (mm)	L (mm)	D (mm)	d (mm)	L1 (mm)	L2 (mm)	WEIGHT (g)	PACKING	
										INNER PC/BOX	OUTER PC/CTN
S10H240	4mm	25	6.3	37	12	10.8	13	21	14	40	240
S10H255	5.5mm	25	6.3	37	12	10.8	13	21	14	40	240
S10H270	7mm	25	6.3	37	12	10.8	13	21	16	40	240

JONNESWAY

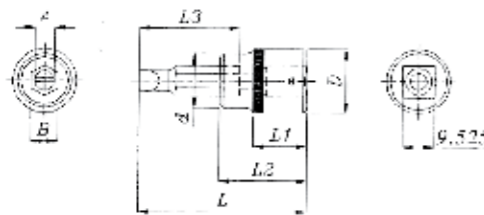

S10H3	3/8" DR. SLOTTED BIT SOCKETS										
	<ul style="list-style-type: none"> • CHROME VANADIUM STEEL • SEMI MAT FINISHED • DIN 5264 / 3120 										

ITEM NO.	A (size)	L3 (mm)	B (mm)	L (mm)	D (mm)	d (mm)	L1 (mm)	L2 (mm)	WEIGHT (g)	PACKING	
										INNER PC/BOX	OUTER PC/CTN
S10H340	4mm	30	6.30	48	18	13.8	15.5	26.5	36	30	240
S10H350	5mm	30	6.30	48	18	13.8	15.5	26.5	36	30	240
S10H355	5.5mm	30	6.30	48	18	13.8	15.5	26.5	36	30	240
S10H360	6mm	30	6.30	48	18	13.8	15.5	26.5	36	30	240
S10H370	7mm	30	6.30	48	18	13.8	15.5	26.5	38	30	240
S10H380	8mm	30	7.88	48	18	15.8	15.5	26.5	40	30	240
S10H3100	10mm	30	10.00	48	20	17.8	15.5	26.5	42	30	240
S10H3120	12mm	30	10.00	48	20	17.8	15.5	26.5	42	30	240

JONNESWAY

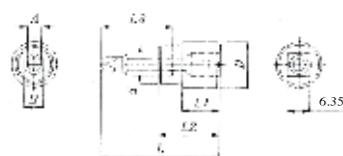

S11H2	1/4" DR. PHILLIPS BIT SOCKETS										
	<ul style="list-style-type: none"> • CHROME VANADIUM STEEL • SEMI MAT FINISHED • DIN 5260 / 3120 										

ITEM NO.	A (size)	L3 (mm)	B (mm)	L (mm)	D (mm)	d (mm)	L1 (mm)	L2 (mm)	WEIGHT (g)	PACKING	
										INNER PC/BOX	OUTER PC/CTN
S11H200	PH0	25	6.30	37	12	10.8	13	19	14	40	240
S11H201	PH1	25	6.30	37	12	10.8	13	19	14	40	240
S11H202	PH2	25	6.30	37	12	10.8	13	19	14	40	240
S11H203	PH3	25	6.30	37	12	10.8	13	19	16	40	240

76



THESE SOCKETS SHOULD NEVER BE USED ON POWER DRIVE OR IMPACT WRENCHES!



S11H3	3/8" DR. PHILLIPS BIT SOCKETS										
	<ul style="list-style-type: none"> • CHROME VANADIUM STEEL • SEMI MAT FINISHED • DIN 5260 / 3120 										

ITEM NO.	A (size)	L3 (mm)	B (mm)	L (mm)	D (mm)	d (mm)	L1 (mm)	L2 (mm)	WEIGHT (g)	PACKING	
										INNER PC/BOX	OUTER PC/CTN
S11H300	PH0	30	6.30	48	18	13.8	16.5	26	36	30	240
S11H301	PH1	30	6.30	48	18	13.8	16.5	26	36	30	240
S11H302	PH2	30	6.30	48	18	13.8	16.5	26	36	30	240
S11H303	PH3	30	6.30	48	18	15.8	16.5	26	38	30	240
S11H304	PH4	30	7.88	48	18	15.8	16.5	26	42	30	240

JONNESWAY



S12H2	1/4" DR. POZI BIT SOCKETS										
	<ul style="list-style-type: none"> • CHROME VANADIUM STEEL • SEMI MAT FINISHED 										

ITEM NO.	A (size)	L3 (mm)	B (mm)	L (mm)	D (mm)	d (mm)	L1 (mm)	L2 (mm)	WEIGHT (g)	PACKING	
										INNER PC/BOX	OUTER PC/CTN
S12H200	PZ0	25	6.30	37	12	10.8	13	19	14	40	240
S12H201	PZ1	25	6.30	37	12	10.8	13	19	14	40	240
S12H202	PZ2	25	6.30	37	12	10.8	13	19	14	40	240
S12H203	PZ3	25	6.30	37	12	10.8	13	19	16	40	240

JONNESWAY



S12H3	3/8" DR. POZI BIT SOCKETS										
	<ul style="list-style-type: none"> • CHROME VANADIUM STEEL • SEMI MAT FINISHED 										

ITEM NO.	A (size)	L3 (mm)	B (mm)	L (mm)	D (mm)	d (mm)	L1 (mm)	L2 (mm)	WEIGHT (g)	PACKING	
										INNER PC/BOX	OUTER PC/CTN
S12H300	PZ0	30	6.30	48	18	13.8	16.5	26	36	30	240
S12H301	PZ1	30	6.30	48	18	13.8	16.5	26	36	30	240
S12H302	PZ2	30	6.30	48	18	13.8	16.5	26	36	30	240
S12H303	PZ3	30	6.30	48	18	13.8	16.5	26	38	30	240
S12H304	PZ4	30	7.88	48	18	15.8	16.5	26	42	30	240

77



THESE SOCKETS SHOULD NEVER BE USED ON POWER DRIVE OR IMPACT WRENCHES!



S15U43S 3PCS POWERFUL UNIVERSAL JOINT SET

SIZE	D1	D2	L1	L2
1/4" F x 1/4" M	18	16	39	43
3/8" F x 3/8" M	24	22	51	58
1/2" F x 1/2" M	30	28	65	72

JONNESWAY



S15H UNIVERSAL JOINTS
• CHROME VANADIUM STEEL
• DIN 3123

• Mat Finished

ITEM NO.	S (size)	D1 (mm)	D2 (mm)	L (mm)	WEIGHT (g)	PACKING	
						INNER PC/BOX	OUTER PC/CTN
S15H472	1/2"	25	25	69	150	10	80
S15H356	3/8"	18	18	49	70	24	216
S15H240	1/4"	14	14	35	30	60	540

• Polish Finished

ITEM NO.	S (size)	D1 (mm)	D2 (mm)	L (mm)	WEIGHT (g)	PACKING	
						INNER PC/BOX	OUTER PC/CTN
S15H6109	3/4"	39.7	39.5	106.2	535	15	30

JONNESWAY

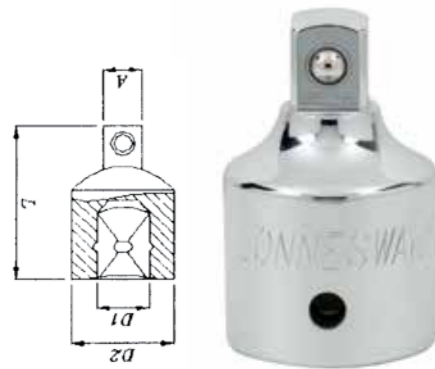

S16H ADAPTERS
• CHROME VANADIUM STEEL
• DIN 3123

• Mat Finished

ITEM NO.	S (size)	A (mm)	D1 (mm)	D2 (mm)	L (mm)	WEIGHT (g)	PACKING	
							INNER PC/BOX	OUTER PC/CTN
S16H1438	1/4" (F) x 3/8" (M)	9.52	6.35	14	25	16	60	1080
S16H3812	3/8" (F) x 1/2" (M)	12.7	9.52	17	35	44	40	360
S16H1238	1/2" (F) x 3/8" (M)	9.52	12.7	22	34	52	30	270

• Polish Finished

ITEM NO.	S (size)	A (mm)	D1 (mm)	D2 (mm)	L (mm)	WEIGHT (g)	PACKING	
							INNER PC/BOX	OUTER PC/CTN
S16H1234	1/2" (F) x 3/4" (M)	19.05	12.7	27	45	134	50	100
S16H1034	1" (F) x 3/4" (M)	19.05	26.0	50	60	362	25	50
S16H3412	3/4" (F) x 1/2" (M)	12.7	19.05	35	51	186	25	50
S16H3410	3/4" (F) x 1" (M)	25.3	19.05	39.7	59.6	360	25	50

JONNESWAY

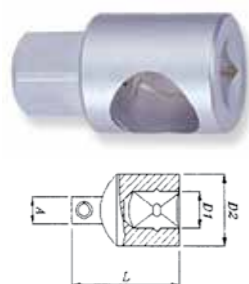

S16 ADAPTERS
• CHROME VANADIUM STEEL
• MAT FINISHED
• DIN 3123

ITEM NO.	S (size)	A (mm)	D1 (mm)	D2 (mm)	L (mm)	WEIGHT (g)	PACKING	
							INNER PC/BOX	OUTER PC/CTN
S16H302	1/4" (M) x 3/8" (F)	6.35	9.75	18.6	28	28.6	60	720
S16H304	1/2" (M) x 3/8" (F)	12.7	9.75	23.5	43.7	67.8	25	225
S16H403	3/8" (M) x 1/2" (F)	9.5	12.9	23.5	40	64.6	20	300

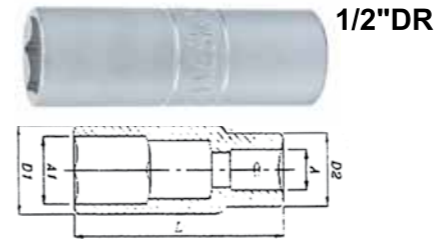

JONNESWAY

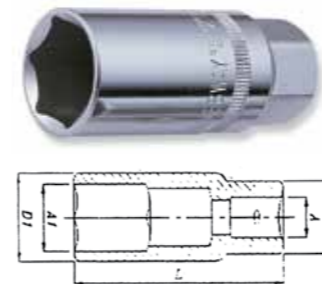

JONNESWAY



JONNESWAY



JONNESWAY



S17H SPARK PLUG SOCKETS
• INSIDE SLEEVE - RUBBER
• CHROME VANADIUM STEEL
• MAT FINISHED
• DIN 3120

ITEM NO.	S (size)	A (mm)	D1 (mm)	D2 (mm)	L (mm)	WEIGHT (g)	PACKING	
							INNER PC/BOX	OUTER PC/CTN
S17H4116	1/2" DR. *16mm	12.700	21.8	21.8	65	92	40	160
S17H4121	1/2" DR. *21mm	12.700	27.6	23.6	65	146	20	80

S17M SPARK PLUG SOCKETS W/MAGNETIC
• INSIDE SLEEVE - MAGNETIC
• CHROME VANADIUM STEEL
• MAT FINISHED
• DIN 3120

ITEM NO.	S (size)	A (mm)	D1 (mm)	D2 (mm)	L (mm)	WEIGHT (g)	PACKING	
							INNER PC/BOX	OUTER PC/CTN
S17M3116	3/8" DR. *16mm	9.525	21.7	18.8	65	110	100	200
S17M3121	3/8" DR. *21mm	9.525	27.6	21.5	65	160	50	100
S17M4116	1/2" DR. *16mm	12.700	21.8	21.8	65	110	100	200
S17M4121	1/2" DR. *21mm	12.700	27.6	23.6	65	166	50	100

S27H FLEXIBLE EXTENSION BARS
• CHROME VANADIUM STEEL
• CHROME PLATED

ITEM NO.	S (size)	L (mm)	WEIGHT (g)	PACKING	
				INNER PC/BOX	OUTER PC/CTN
S27H2	1/4"	145	57	50	300
S27H3	3/8"	193	280	50	100
S27H4	1/2"	205	285	25	50

S24H EXTENSION BARS
• CHROME VANADIUM STEEL
• DIN 3123

• Mat Finished

ITEM NO.	S (size)	L (mm)	WEIGHT (g)	PACKING	
				INNER PC/BOX	OUTER PC/CTN
S24H250	1/4"	50	22	30	540
S24H275	1/4"	75	34	40	600
S24H2100	1/4"	100	44	40	480
S24H2150	1/4"	150	63	25	200
S24H375	3/8"	75	78	20	160
S24H3150	3/8"	150	150	20	80
S24H3225	3/8"	225	225	10	100
S24H3300	3/8"	300	305	10	40
S24H450	1/2"	50	110	12	216
S24H475	1/2"	75	112	10	150
S24H4125	1/2"	125	198	10	90
S24H4250	1/2"	250	394	5	45

• Polish Finished

ITEM NO.	S (size)	L (mm)	WEIGHT (g)	PACKING	
				INNER PC/BOX	OUTER PC/CTN
S24H6100	3/4"	100	426	30	60
S24H6150	3/4"	150	558	10	30
S24H6200	3/4"	200	734	10	30
S24H6400	3/4"	400	1386	10	20
S24H8200	1"	200	1300	10	20
S24H8400	1"	400	2420	5	10

S60H4304S 4PCS 1/2" DR. LOCK EXTENSION BAR SET

- Material: CR-V
- Polished Finish
- S60H4304S: 3", 5", 10", 15"



THESE SOCKETS SHOULD NEVER BE USED ON POWER DRIVE OR IMPACT WRENCHES!



THESE SOCKETS SHOULD NEVER BE USED ON POWER DRIVE OR IMPACT WRENCHES!

SOCKETS SERIES

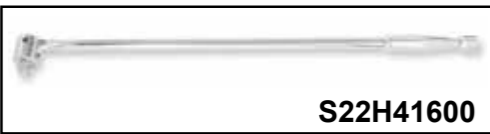

S22H41600

S22H	FLEXIBLE HANDLES					
	<ul style="list-style-type: none"> • CHROME VANADIUM STEEL • DIN 3122 					

• Mat Finished

ITEM NO.	S (size)	L (mm)	WEIGHT (g)	PACKING	
				INNER PC/BOX	OUTER PC/CTN
S22H41375	1/2"	375	696	15	30
S22H41450	1/2"	450	790	10	20
S22H31200	3/8"	200	294	30	60
S22H21150	1/4"	150	120	30	100

• Polish Finished

ITEM NO.	S (size)	L (mm)	WEIGHT (g)	PACKING	
				INNER PC/BOX	OUTER PC/CTN
S22H6500	3/4"	500	1880	7/8	15
S22H41600	1/2"	600	1332	5	20

JONNESWAY

S23H	SLIDING BARS					
	<ul style="list-style-type: none"> • CHROME VANADIUM STEEL • DIN 3122 					

• Mat Finished

ITEM NO.	S (size)	L (mm)	WEIGHT (g)	PACKING	
				INNER PC/BOX	OUTER PC/CTN
S23H21130	1/4"	130	48	250	500
S23H31200	3/8"	200	157	50	100
S23H41250	1/2"	250	440	25	50
S23H41300	1/2"	300	465	25	50

• Polish Finished

ITEM NO.	S (size)	L (mm)	WEIGHT (g)	PACKING	
				INNER PC/BOX	OUTER PC/CTN
S23H6450	3/4"	450	1213	10	20
S23H6500	3/4"	500	1322	10	20
S23H8660	1"	660	3760	3	6

JONNESWAY

S40H	SLIDING T-HANDLE SOCKETS								
	<ul style="list-style-type: none"> • CHROME VANADIUM STEEL • MAT FINISHED 								

ITEM NO.	S (size)	D (mm)	D1 (mm)	L (mm)	L1 (mm)	WEIGHT (g)	PACKING	
							INNER PC/BOX	OUTER PC/CTN
S40H108	8	12.5	10	300	200	300	25	50
S40H109	9	14	10	300	200	310	25	50
S40H110	10	14.8	10	300	200	320	25	50
S40H111	11	15.5	10	300	200	330	25	50
S40H112	12	16.8	10	300	200	340	25	50
S40H113	13	18.0	10	300	200	350	25	50
S40H114	14	19.0	10	300	200	350	25	50



JONNESWAY



JONNESWAY

S04H6121S 21PCS 3/4" DR. 6PT FLANK SOCKET SET(MM)	
R1206	1PC-3/4" DR. 500MM (20") REVERSIBLE RATCHET HANDLE
S22H6475	1PC-3/4" DR. FLEXIBLE HANDLE (475MM)
S24H6100	1PC-3/4" DR. 100MM (4") EXTENSION BAR
S24H6200	1PC-3/4" DR. 200MM (8") EXTENSION BAR
S24H6400	1PC-3/4" DR. 400MM (16") EXTENSION BAR
S16H3412	1PC-3/4"FX1/2"M ADAPTER
S16H3410	1PC-3/4"FX1"M ADAPTER
S04H61	12PCS-6PT SOCKETS : 19, 21, 22, 24, 27, 30, 32, 36, 38, 41, 46, 50MM
S15H6109	1PC-UNIVERSAL JOINT
	1PC-BLOW CASE (530X340X85MM)
PACKING	BLOW CASE 1SET/CTN/15KGS/15.5KGS/0.71'



JONNESWAY

S04H4724S 24PCS 1/2" DR. SOCKET SET	
CONTENTS:	
S04H41	18PCS-1/2" DR. SOCKET 8, 9, 10, 11, 12, 13, 14, 15, 16, 17, 18, 19, 21, 22, 24, 27, 30, 34MM
S15H472	1PC-UNIVERSAL JOINT
S24H4	2PCS-EXTENSION BAR 5" & 10"
S23H4125	1PC-SLIDING T BAR
S17H4116	1PC-16MM SPARK PLUG SOCKET
R3704	1PC-48 TEETH QUICK RELEASE RATCHET HANDLE
PACKING	METAL CASE + COLOR BOX 5SETS/CTN/24.5KGS/25KGS/0.98'

- Chrome Vanadium Steel, Professional Quality
- DIN Standard
- Quick Release Ratchet Handle With Reversible Function
- Smooth Precise Ratchet Operation
- Rounded-Off Nut/Bolt Can Be Loosened
- Increasing Torsion More Than 10%



JONNESWAY

S04H4125S 25PCS 1/2" DR. SOCKET SET	
CONTENTS:	
S04H4	18PCS-1/2" DR. SOCKETS : 10, 11, 12, 13, 14, 15, 16, 17, 18, 19, 20, 21, 22, 23, 24, 27, 30, 32MM
S17H4	2PCS-SPARK PLUG SOCKET 16 & 21MM
S24H4	2PCS-EXTENSION BAR 5" & 10"
S23H4125	1PC-SLIDING T BAR
S15H472	1PC-UNIVERSAL JOINT
R3704	1PC-1/2" DR. RATCHET HANDLE-48 TEETH
PACKING	METAL CASE + COLOR BOX 5SET/CTN/25.2KGS/25.7KGS/0.97'



JONNESWAY

S04H458S 58PCS 1/2" DR. 6PT FLANK SOCKET & BIT SET	
CONTENTS:	
S15H472	17PCS-1/2" DR. 6PT SOCKETS : 10, 11, 12, 13, 14, 15, 16, 17, 18, 19, 20, 21, 22, 24, 27, 30, 32MM
S04HD4	8PCS-1/2" DR. DEEP SOCKETS : 10, 11, 12, 13, 14, 15, 17, 19MM
S24H	2PCS-1/2" DR. 5" & 10" EXTENSION BAR
S15H472	1PC-1/2" DR. UNIVERSAL JOINT
S16H304	1PC-3/8"(F) X 1/2"(M) T-BAR ADAPTER
R3504	1PC-1/2" DR. 10" QUICK RELEASE RACHET HANDLE-72 TEETH
S17H4	2PCS-1/2" DR. 16MM & 21MM SPARK PLUG SOCKET
	1PC-1/2" DR. BIT ADAPTOR
	25PCS-BIT X 30L (φ 1/4") :
	-PHILLIPS : #1, #2, #3, #4
	-SLOTTED : 4, 5.5, 7MM
	-HEX : 3, 4, 5, 5.5, 6, 7, 8MM
	-STAR : T10, T15, T20, T25, T27, T30, T40
	-POZI : #1, #2, #3, #4
PACKING	BLOW CASE + COLOR BOX 3SET/CTN/16KGS/16.6KGS/1.34'

THESE SOCKETS SHOULD NEVER BE USED ON POWER DRIVE OR IMPACT WRENCHES!



THESE SOCKETS SHOULD NEVER BE USED ON POWER DRIVE OR IMPACT WRENCHES!



S04H52460S 60PCS 1/2" & 1/4" DR. TOOL KIT

CONTENTS:

S04H41	9PCS-1/2" DR. SOCKETS : 12, 13, 14, 15, 17, 18, 19, 22, 24,MM
R2904	1PC-1/2" DR. 36TEETH QUICK RELEASE RATCHET HANDLE
S24H	2PCS-1/2" DR. EXTENSION 125MM (5") & 250MM (10")
S16H304	1PC-3/8" (F) X 1/2" (M) ADAPTER FOR EXTENSION
S15H472	1PC-1/2" DR. UNIVERSAL JOINT
S17H	2PCS-1/2" DR. SPARK PLUG SOCKET 16 & 21MM
S04H21	7PCS-1/4" DR. SOCKETS : 6, 8, 9, 10, 11, 12, 13MM
S24H275	1PC-1/4" DR. EXTENSION BAR 75MM (3") 1PC-1/4" DR. FLEXIBLE EXTENSION
S23H21130	1PC-1/4" DR. SLIDING T HANDLE
S26H2150	1PC-1/4" DR. SPINNER HANDLE 1PC-1/4" DR. COUPLER
	18PCS 1/4" DR. BITS : SLOTTED : 3, 4, 5, 6MM TORX : T10, T15, T20, T25, T27, T30, T40 PHILLIPS : #1, #2, #3 HEX : 3, 4, 5, 6MM
W261	6PCS-COMBINATION WRENCH : 8, 10, 12, 13, 14, 17MM
P2810	1PC-BOX JOINT PLIERS
P087	1PC-CUTTING PLIER
M09500	1PC 500G ENGINER'S HAMMER WITH HICKORY HANDLE (GS)
D04	4PCS-FULL STAR SCREWDRIVERS : PH1X80MM(+), PH2X100MM(+) 0.8X4X80MM(-), 1.2X6.5X100MM(-)
PACKING	BLOW CASE + COLOR BOX 4SET/CTN/23KGS/23.5KGS/1.47'

- Professional Quality
- 36 Teeth Ratchet Handle Quick Release With Reversible Function
- Increasing Torsion More Than 10%
- Chrome Vanadium Steel
- DIN Standard

JONNESWAY



S04H52494S 94PCS 1/4" & 1/2" DR. COMBINATION SOCKET SET

CONTENTS:

1/4" DR. PART	
S04H21	13PCS-6PT FLANK SOCKETS : 4, 4.5, 5, 5.5, 6, 7, 8, 9, 10, 11, 12, 13, 14MM
S04HD21	8PCS-6PT DEEP FLANK SOCKETS : 6, 7, 8, 9, 10, 11, 12, 13MM
	18PCS-SOCKET BIT (L : 37MM) HEX : 3, 4, 5, 6MM STAR : T8, T10, T15, T20, T25, T27, T30 SLOTTED : 4, 5.5, 6.5MM PHILLIPS : PH1, PH2, POZI : PZ1, PZ2
R3702	1PC-48 TEETH RATCHET HANDLE
S23H21130	1PC-SLIDING T BAR
S15H240	1PC-UNIVERSAL JOINT
S24H	2PCS-EXTENSION BARS : 2", 4"
S26H2150	1PC-SPINNER HANDLE 3PCS-HEX KEY : 1.5, 2, 2.5MM
1/2" DR. PART	
S04H41	17PCS-6PT FLANK SOCKETS : 10, 11, 12, 13, 14, 15, 16, 17, 18, 19, 20, 21, 22, 24, 27, 30, 32MM
S04HD41	5PCS-6PT FLANK DEEP SOCKETS : 14, 15, 17, 19, 22MM
	16-5/16" BIT (L : 30MM) HEX : 7, 8, 10, 12, 14MM STAR : T40, T45, T50, T55 SLOTTED : 8, 10, 12MM PHILLIPS : PH3, PH4, POZI : PZ3, PZ4
R3704	1PC-48 TEETH RATCHET HANDLE
S17H	2PCS-SPARK PLUG SOCKETS : 16, 21MM
S24H	2PCS-EXTENSION BAR : 5", 10"
S15H472	1PC-UNIVERSAL JOINT
S44H4208	1PC-BIT HOLDER 5/16"
S16H304	1PC-ADAPTER FOR EXTENSION 3/8" DR. X 1/2" (M)
PACKING	BLOW CASE + COLOR BOX 3SET/CTN/18.2KGS/18.7KGS/1.15'

- Professional Quality
- DIN Standard
- Chrome Vanadium Steel
- Increasing Torsion More Than 10%
- Quick Release Ratchet Handle with Anti - Slip Grip

JONNESWAY

S04H52482S 82PCS 1/4" & 1/2" DR. COMBINATION SOCKET SET

CONTENTS:

1/4" DR. PART	
S04H21	13PCS-6PT FLANK SOCKETS : 4, 4.5, 5, 5.5, 6, 7, 8, 9, 10, 11, 12, 13, 14MM
	17PCS-SOCKET BIT (L : 37MM) HEX : 3, 4, 5, 6MM STAR : T8, T10, T15, T20, T25, T30 SLOTTED : 4, 5.5, 7MM PHILLIPS : PH1, PH2, POZI : PZ1, PZ2
R3702	1PC-48 TEETH RATCHET HANDLE
S23H21130	1PC-SLIDING T HANDLE
S24H	2PCS-EXTENSION 2", 4"
S15H240	1PC-UNIVERSAL JOINT
S27H2	1PC-FLEXIBLE EXTENSION
S26H2150	1PC-SPINNER HANDLE 1PC-BIT ADAPTER (25MMML)
1/2" DR. PART	
S04H41	12PCS-6PT FLANK SOCKETS : 14, 15, 16, 17, 18, 19, 20, 22, 24, 27, 30, 32MM
	15PCS-5/16" BIT (L : 30MM) HEX : 8, 10, 12, 14MM STAR : T40, T45, T50, T55 SLOTTED : 8, 10, 12MM PHILLIPS : PH3, PH4, POZI : PZ3, PZ4
S24H	2PCS-EXTENSION : 5", 10"
S17H	2PCS-SPARK PLUG SOCKETS : 16, 21MM
S44H208	1PC-BIT HOLDER 1/2" DR. X 5/16"
R3704	1PC-48 TEETH RATCHET HANDLE
S15H472	1PC-UNIVERSAL JOINT
S16H304	1PC-ADAPTER FOR EXTENSION 3/8" (F) X 1/2" (M)
W261	9PCS-COMBINATION WRENCH : 8, 10, 11, 12, 13, 14, 17, 19, 22MM
PACKING	BLOW CASE + COLOR BOX 3SET/CTN/17.3KGS/17.8KGS/1.15'

- Professional Quality
- DIN Standard
- Chrome Vanadium Steel
- Increasing Torsion More Than 10%
- Quick Release Ratchet Handle with Anti-slip Grip



S04H524127S 127CS 1/2" DR. & 1/4" DR. TOOL KIT

CONTENTS:

S04H2	12PCS-1/4"DR. SOCKETS: 4, 4.5, 5, 5.5, 6, 7, 8, 9, 10, 11, 12, 13MM
S04HD2	5PCS-1/4"DR. DEEP SOCKETS: 7, 8, 10, 12, 13MM
S06H2	5PCS-1/4"DR. STAR SOCKETS: E4, E5, E6, E7, E8
S04H4	18PCS-1/2"DR. SOCKETS: 8, 9, 10, 11, 12, 13, 14, 15, 16, 17, 18, 19, 21, 22, 24, 27, 30, 32MM
S04HD4	7PCS-1/2"DR. DEEP SOCKETS: 10, 12, 13, 14, 15, 17, 19MM
S06H4	8PCS-1/2"DR. STAR SOCKETS: E10, E12, E14, E16, E18, E20, E22, E24
S17H	2PCS-1/2"DR. SPARK PLUG SOCKETS: 16, 21MM
S21H	3PCS-WOBBLE EXTENSION BARS: 1/4"DR.X50, 1/4"DR.X150, 1/2"DR.X50MM
S23H	2PCS-SLIDING T-BARS: 1/4"DR.X130, 1/2"DR.X250MM
S15H	2PCS-UNIVERSAL JOINT: 1/4"&1/2"DR.
S24H	3PCS-EXTENSION BARS: 1/2"DR.X125, 1/2"DR.X250, 1/4"DR.X75MM
S27H2	1PC-FLEXIBLE EXTENSION BARS: 1/4"DR.X145MM
S22H41375	1PC-FLEXIBLE HANDLE: 1/2"DR.X375MM
R29	2PCS-36 TEETH RATCHET HANDLE: 1/4"&1/2"DR.
W26	19PCS-COMBINATION WRENCH: 6, 7, 8, 9, 10, 11, 12, 13, 14, 15, 16, 17, 19, 21, 22, 24, 27, 30, 32MM
W24	5PCS-FLARE NUT WRENCH: 8X10, 9X11, 12X13, 14X17, 17X19MM
H01SM109S	9PCS-SHORT ARM HEX KEY SET: 1.5, 2, 2.5, 3, 4, 5, 6, 8, 10MM
H08M07S	7PCS-STAR KEY SET: T10, T15, T20, T25, T27, T30, T40
M64M105S	5PCS-CHISEL-PUNCH SET: 4X9.5X150, 5X9.5X130, 12X9.5X130, 3X9.5X120, NO.2X9.5X120MM
P2810	1PC-10" BOX JOINT PLIERS
P8606	1PC-6" DIAGONAL CUTTING PLIERS
P8007	1PC-7" COMBINATION PLIERS
AG010034	1PC-MAGNETIC PICK-UP TOOL
M09500	1PC-500G HAMMER
D71	6PCS-ANTI-SLIP GRIP SCREWDRIVER: PH2X38, PH2X100, PH1X75MM, SL6.5X38, SL6X100, SL5X75MM

- Professional Quality
- DIN Standard
- Chrome Vanadium Steel
- Increasing Torsion More Than 10%
- Quick Release Ratchet Handle with Anti - Slip Grip



THESE SOCKETS SHOULD NEVER BE USED ON POWER DRIVE OR IMPACT WRENCHES!



THESE SOCKETS SHOULD NEVER BE USED ON POWER DRIVE OR IMPACT WRENCHES!



S04H3125S 25PCS 3/8" DR. SOCKET SET

CONTENTS:

S04H3	17PCS-3/8" DR. SOCKETS : 6, 7, 8, 9, 10, 11, 12, 13, 14, 15, 16, 17, 18, 19, 20, 21, 22MM
R3703	1PC-1-3/8" DR. RATCHET HANDLE-48 TEETH
S24H3	2PCS-EXTENSION BARS 3" & 6"
S23H31200	1PC -SLIDING T BAR
S15H356	1PC-UNIVERSAL JOINT
S17H3	2PCS-SPARK PLUG 16 & 21MM
PACKING	METAL CASE + COLOR BOX 10SET/CTN/26KGS/27.1KGS/1.17'

JONNESWAY



S04H3120S 20PCS 3/8" DR. SOCKET SET

CONTENTS:

S04H3	13PCS-3/8" DR. SOCKETS : 6, 7, 8, 9, 10, 11, 12, 13, 14, 17, 19, 21, 23MM
S17H3121	1PC-SPARK PLUG 21MM
R2903	1PC-3/8" DR. RATCHET HANDLE-36 TEETH
S24H3	2PCS-EXTENSION BARS 3" & 6"
S22H31200	1PC-FLEXIBLE HANDLE 8"
S23H31200	1PC-SLIDING T-HANDLE 8"
S15H356	1PC-UNIVERSAL JOINT
PACKING	METAL CASE + COLOR BOX 5SET/CTN/21KGS/21.5KGS/0.97'

JONNESWAY



S04H3536S 36PCS 3/8" DR. COMBINATION TOOL SET

CONTENTS:

S04H3	17PCS-3/8" DR.6PT FLANK SOCKETS: 6,7,8,9,10,11,12,13,14, 15,16,17,18,19,20,21,22MM
W26	11PCS-COMBINATION WRENCH: 7,8,9,10,11,12,13,14,15,16,17MM
R3503	1PC-72 TEETH RATCHET HANDLE
S24H	3PCS-EXTENSION:3",6",9"
S17H	2PCS-SPARK PLUG SOCKETS:16,21MM
S15H356	1PC-UNIVERSAL JOINT
S16H403	1PC-ADAPTER FOR EXTENSION, 1/2"(F)X3/8"(M)
PACKING	METAL CASE+ COLOR BOX 5SETS/CTN/21KGS/21.5KGS/0.97'

JONNESWAY



S04H3157S 57PCS 1/4" & 3/8" DR. COMBINATION SOCKET SET

CONTENTS:

1/4" DR. PARTS	
S04H2	12PCS-SOCKETS : 4, 4.5, 5, 5.5, 6, 7, 8, 9, 10, 11, 12, 13MM
S04HD2	4PCS-DEEP SOCKETS : 8, 10, 12, 13MM
S09H2	16PCS-SOCKET BIT HEX 3, 4, 5, 6MM
S11H2	STAR : T10, T15, T20, T25, T27, T30
S10H2	SLOTTED 4, 5.5, 7MM PHILLIPS PH1, PH2, PH3
R3702	1PC-RATCHET HANDLE-48 TEETH
S24H2	2PCS-EXTENSION BARS 2" & 6"
S16H302	1PC-ADAPTER FOR EXTENSION 1/4" (M) X 3/8" (F)
S15H240	1PC-UNIVERSAL JOINT
S26H2150	1PC-SPINNER HANDLE
3/8" DR. PARTS	
S04H3	8PCS-SOCKETS : 14, 15, 17, 18, 19, 20, 22, 24MM
S04HD3	3PCS-DEEP SOCKETS : 14, 15, 17MM
R3703	1PC-RATCHET HANDLE-48 TEETH
S17H3	2PCS-SPARK PLUG SOCKETS : 16,21MM
S15H356	1PC-UNIVERSAL JOINT
S16H403	1PC-ADAPTER FOR EXTENSION 3/8" (M) X 1/2" (F)
S24H3	2PCS-EXTENSION BARS 3" & 10"
PACKING	METAL CASE + COLOR BOX 5SETS/CTN/21.5KGS/22KGS/0.98'



S04H2118S 18PCS 1/4" DR. SOCKET SET

CONTENTS:

S04H2	12PCS-1/4" DR. 6POINT SOCKETS : 4, 4.5, 5, 5.5, 6, 7, 8, 9, 10, 11, 12, 13MM
R2902	1PC-1/4" DR. RATCHET HANDLE-36 TEETH
S24H2	2PCS-EXTENSION BARS 2" & 4"
S22H2150	1PC-FLEXIBLE HANDLE 6"
S23H2	1PC-SLIDING T-HANDLE 4-1/2"
S15H240	1PC-UNIVERSAL JOINT
PACKING	METAL CASE + COLOR BOX 5SETS/CTN/9KGS/10KGS/0.7'

JONNESWAY



S04H2125S 25PCS 1/4" DR. SOCKET SET

CONTENTS:

S04H2	11PCS-1/4" DR. SOCKETS : 4, 5, 5.5, 6, 7, 8, 9, 10, 11, 12, 13MM
S04HD2	9PCS-1/4" DR. DEEP SOCKETS : 5, 6, 7, 8, 9, 10, 11, 12, 13MM
R3702	1PC-1/4" DR. RATCHET HANDLE-48 TEETH
S24H2	2PCS-1/4" DR. EXTENSION BARS 2" & 6"
S26H2150	1PC-SPINNER HANDLE
PACKING	METAL CASE + COLOR BOX 12SETS/CTN/9KGS/10KGS/0.72'

JONNESWAY



S04H2141S 41PCS 1/4" DR. SOCKET SET

CONTENTS:

S04H2	10PCS-1/4" DR. SOCKETS : 4, 5, 5.5, 6, 7, 8, 10, 11, 12, 13MM
S04HD2	3PCS-1/4" DR. DEEP SOCKETS : 7, 8, 10MM
S09H2	4PCS-HEX SOCKET BIT : 3, 4, 5, 6MM
S07H2	6PCS-STAR SOCKET BIT : T10, T20, T25, T27, T30, T40
S10H2	3PCS-SLOTTED SOCKET BIT : 0.8X4, 10X5.5, 1.2X7
S11H2	3PCS-PHILLIPS SOCKET BIT : H1, PH2, HP3
R3702	1PC-1/4"DR RATCHET HANDLE-48 TEETH
S24H	2PCS-EXTENSION BARS 2" & 6"
S27H2150	1PC-FLEXIBLE EXTENSION 6"
S15H240	1PC-UNIVERSAL JOINT
S26H2150	1PC-SPINNER HANDLE
S16H3814	1PC-ADAPTER FOR EXTENSION : 3/8" DR. (F) X 1/4" DR. (M)
	4PCS-HEX KEY WRENCH : 1.5, 2, 2.5, 3MM
PACKING	METAL CASE + COLOR BOX 5SETS/CTN/9KGS/10KGS/0.7'

JONNESWAY



S06H425S 25PCS 1/4" & 1/2" DR. STAR SOCKET SET

CONTENTS:

S07H2	7PCS -1/4" DR. STAR BIT SOCKET (L : 32MM) T8, T10, T15, T20, T25, T27, T30
S07H3	5PCS -1/2" DR. STAR BIT SOCKET (L : 55MM) T40, T45, T50, T55, T60
S06H2	5PCS-1/4" DR. STAR SOCKE E4, E5, E6, E7, E8
S06H4	5PCS-1/2" DR. STAR SOCKE E10, E11, E12, E14, E18
H08	3PCS-STAR KEY T6, T8, T10
PACKING	METAL CASE + COLOR BOX 16SETS/CTN/16KGS/17KGS/0.7'

85

84



THESE SOCKETS SHOULD NEVER BE USED ON POWER DRIVE OR IMPACT WRENCHES!



THESE SOCKETS SHOULD NEVER BE USED ON POWER DRIVE OR IMPACT WRENCHES!



S05H4916S 16PCS 1/2" DR. SOCKET SET (SAE)

CONTENTS:

S05H49	13PCS-1/2" DR. 12PT SOCKETS : 7/16", 1/2", 9/16", 5/8", 11/16", 3/4", 13/16", 7/8", 15/16", 1", 1-1/16", 1-1/8", 1-1/4"
S22HC4380	1PC-1/2" DR. 15" FLEX HANDLE
S24HC4125	1PC-1/2" DR. 5" EXTENSION BAR
R2804Q	1PC-1/2" DR. QUICK RELEASE RATCHET HANDLE
PACKING	METAL CASE + COLOR BOX 5SETS/CTN/21.2KGS/22.2KGS/0.82'

JONNESWAY



S05H2223S 23PCS 1/4" DR. SOCKET SET (SAE)

CONTENTS:

S05H2	10PCS-1/4" DR. 6PT SOCKETS (CR-V) : 5/32", 3/16", 7/32", 1/4", 9/32", 5/16", 11/32", 3/8", 7/16", 1/2"
S05HD2	8PCS-1/4" DR. 6PT DEEP SOCKETS (CR-V) : 3/16", 7/32", 1/4", 9/32", 5/16", 11/32", 3/8", 7/16"
S24HC2	2PCS-1/4" DR. 3" & 6" EXTENSION BARS (CR-V)
	1PC-1/4" DR. UNIVERSAL JOINT (CR-V)
S34HC2165	1PC-1/4" DR. 6-1/2" SPINNER HANDLE
R2802Q	1PC-1/4" DR. 5-1/2" QUICK RELEASE RATCHET HANDLE (48 TEETH) (GEAR TO GEAR) (CR-V)
PACKING	METAL CASE + COLOR BOX 10SETS/CTN/12KGS/14KGS/0.46'



S06H310S 10PCS 1/4" & 3/8" DR. STAR SOCKET SET

CONTENTS:

S06H2	4PCS-1/4" DR. : E4, E6, E7, E8
S06H3	6PCS-3/8" DR. : E10, E11, E12, E14, E16, E18
PACKING	METAL CLIP RAIL + SLIDE CARD 5SETS/CTN/9KGS/10KGS/0.7'

JONNESWAY



S14H310S 10PCS 3/8" DR. FLEX UNIVERSAL SOCKET SET

CONTENTS:

S14H3	10PCS-10, 11, 12, 13, 14, 15, 16, 17, 18, 19mm
PACKING	METAL CLIP RAIL + SLIDE CARD 5SETS/CTN/9KGS/10KGS/0.7'

JONNESWAY



S64H4126S 26PCS 1/2" DR. SPLINE SOCKET BITS SET

CONTENTS:

- MATERIAL : BIT S2
- SOCKET : CR-V
- 8 PCS 55MM(L) : M5, M6, M8, M9, M10, M12, M14, M16
- 7 PCS 100MM(L) : M5, M6, M8, M9, M10, M12, M14
- 7 PCS 140MM(L) : M5, M6, M8, M9, M10, M12, M14
- 4 PCS 200MM(L) : M8, M10, M12, M14

JONNESWAY



S09H4930S 30PCS 1/2" DR. HEX SOCKET BITS SET

CONTENTS:

- MATERIAL : BIT S2 SOCKET : CR/V
- 9 PCS 55MM(L) : 5, 6, 7, 8, 10, 12, 14, 17, 19MM
- 8 PCS 100MM(L) : 5, 6, 7, 8, 10, 11, 12, 13MM
- 7 PCS 140MM(L) : 5, 6, 7, 8, 10, 12, 14MM
- 6 PCS 200MM(L) : 5, 6, 7, 8, 10, 12MM

JONNESWAY



S07H4932S 32PCS 1/2" DR. STAR SOCKET BITS SET

CONTENTS:

- MATERIAL : BIT S2 SOCKET : CR/V
- 10 PCS 55MM(L) : T20, T25, T27, T30, T40, T45, T50, T55, T60, T70
- 10 PCS 100MM(L) : T20, T25, T27, T30, T40, T45, T50, T55, T60, T70
- 6 PCS 140MM(L) : T40, T45, T50, T55, T60, T70
- 6 PCS 200MM(L) : T40, T45, T50, T55, T60, T70



THESE SOCKETS SHOULD NEVER BE USED ON POWER DRIVE OR IMPACT WRENCHES!



THESE SOCKETS SHOULD NEVER BE USED ON POWER DRIVE OR IMPACT WRENCHES!

DIN 3129 QUALITY STANDARDS



S03A4 1/2" DR. 6PT FLANK IMPACT SOCKETS (MM)							
• DIN 3129 • CHROME MOLYBDENUM • PHOSPHATE COATING							
ITEM NO.	SIZE (mm)	D1 (mm)	D2 (mm)	L (mm)	WEIGHT (g)	PACKING	
						INNER PC/BOX	OUTER PC/CTN
S03A4108	8	14.6	24	38	56	12	180
S03A4109	9	15.0	24	38	59	12	180
S03A4110	10	17.0	24	38	59	12	180
S03A4111	11	19.0	24	38	63	12	180
S03A4112	12	20.0	24	38	65	12	180
S03A4113	13	20.8	24	38	67	12	180
S03A4114	14	22.0	24	38	71	12	180
S03A4115	15	24.0	24	38	78	12	180
S03A4116	16	24.0	24	38	74	12	180
S03A4117	17	26.0	26	38	87	12	180
S03A4118	18	28.0	27	38	108	12	180
S03A4119	19	28.0	28	38	104	12	180
S03A4120	20	30.0	30	38	139	12	144
S03A4121	21	30.0	30	38	146	12	144
S03A4122	22	32.0	30	38	130	12	144
S03A4123	23	34.0	30	38	119	12	144
S03A4124	24	34.0	30	43	129	12	144
S03A4125	25	35.8	30	43	168	12	144
S03A4126	26	37.0	30	43	160	12	144
S03A4127	27	38.0	30	43	171	12	144
S03A4128	28	39.0	30	48	188	6	72
S03A4129	29	40.0	30	48	214	6	72
S03A4130	30	42.0	30	48	210	6	72
S03A4131	31	44.0	30	48	222	6	72
S03A4132	32	44.6	30	48	224	6	72

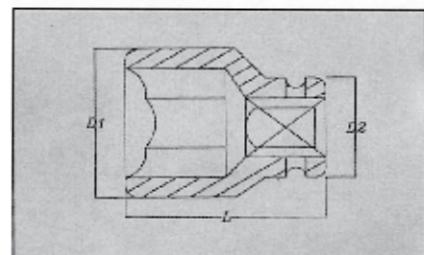

S03A4 1/2" DR. 6PT FLANK IMPACT SOCKETS (SAE)							
• ANSI / ASME B107.2 • CHROME MOLYBDENUM • PHOSPHATE COATING							
ITEM NO.	SIZE (SAE)	D1 (mm)	D2 (mm)	L (mm)	WEIGHT (g)	PACKING	
						INNER PC/BOX	OUTER PC/CTN
S03A4208	5/16"	14.0	24	38	59	12	180
S03A4210	3/8"	16.0	24	38	60	12	180
S03A4211	7/16"	18.4	24	38	62	12	180
S03A4213	1/2"	20.5	24	38	66	12	180
S03A4214	9/16"	22.0	24	38	69	12	180
S03A4216	5/8"	24.0	24	38	74	12	180
S03A4217	11/16"	26.0	26	38	88	12	180
S03A4219	3/4"	28.0	28	38	90	12	180
S03A4221	13/16"	30.0	30	38	123	12	144
S03A4222	7/8"	32.0	30	38	133	12	144
S03A4224	15/16"	36.4	30	38	137	12	144
S03A4226	1"	36.4	30	38	136	12	144
S03A4227	1-1/16"	38.0	30	48	215	12	144
S03A4229	1-1/8"	40.0	30	48	207	6	72
S03A4230	1-3/16"	42.0	30	48	203	6	72
S03A4232	1-1/4"	44.6	30	48	237	6	72

S03A4111S 11PCS 1/2" DR. 6PT FLANK IMPACT SOCKET SET (MM)	
CONTENTS:	11PCS-1/2" DR. 6PT FLANK IMPACT SOCKETS : 10, 11, 12, 13, 14, 16, 17, 19, 21, 22, 24MM
PACKING	BLOW CASE + COLOR BOX 10SETS/CTN/12KGS/13KGS/0.56'



DIN 3129 QUALITY STANDARDS

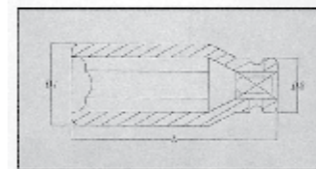

JONNESWAY



JONNESWAY

S03AD4 1/2" DR. 6PT FLANK DEEP IMPACT SOCKETS (MM)							
• DIN 3129 • CHROME MOLYBDENUM • PHOSPHATE COATING							
ITEM NO.	SIZE (mm)	D1 (mm)	D2 (mm)	L (mm)	WEIGHT (g)	PACKING	
						INNER PC/BOX	OUTER PC/CTN
S03AD4110	10	17.0	24	78	140	12	180
S03AD4111	11	19.0	24	78	156	12	180
S03AD4112	12	19.6	24	78	162	12	180
S03AD4113	13	20.8	24	78	166	12	180
S03AD4114	14	22.0	24	78	157	12	180
S03AD4116	16	24.0	24	78	159	12	72
S03AD4117	17	26.0	26	78	185	12	72
S03AD4119	19	28.0	28	78	228	12	72
S03AD4121	21	30.0	30	78	243	12	72
S03AD4124	24	34.6	30	78	303	12	72

S03AD4111S 11PCS 1/2" DR. 6PT FLANK DEEP IMPACT SOCKET SET (MM)	
CONTENTS:	11PCS-1/2" DR. 6PT FLANK DEEP IMPACT SOCKETS : 10, 11, 12, 13, 14, 16, 17, 19, 21, 22, 24MM
PACKING	BLOW CASE + COLOR BOX 10SETS/CTN/12KGS/13KGS/0.53'

DIN 3121 QUALITY STANDARDS

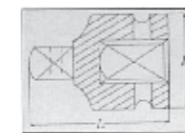

JONNESWAY

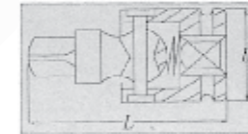

JONNESWAY

S03A4A 1/2" DR. ADAPTERS						
• DIN 3121 • CHROME MOLYBDENUM						
ITEM NO.	SIZE	D (mm)	L (mm)	WEIGHT (g)	PACKING	
					INNER PC/BOX	OUTER PC/CTN
S03A4A3	3/8"	25	38	70	15	120
S03A4A6	3/4"	30	48	140	12	144

S03A4U 1/2" DR. UNIVERSAL JOINT						
• DIN 3121 • CHROME MOLYBDENUM						
ITEM NO.	SIZE	D (mm)	L (mm)	WEIGHT (g)	PACKING	
					INNER PC/BOX	OUTER PC/CTN
S03A4U4	1/2"	25	75	150	12	60

S03A4E 1/2" DR. EXTENSION BARS						
• DIN 3121 • CHROME MOLYBDENUM						
ITEM NO.	SIZE	D (mm)	L (mm)	WEIGHT (g)	PACKING	
					INNER PC/BOX	OUTER PC/CTN
S03A4E3	3"	25	75	170	15	180
S03A4E4	4"	25	100	200	10	120
S03A4E5	5"	25	125	230	5	50
S03A4E6	6"	25	150	260	12	120
S03A4E8	8"	25	200	340	6	72
S03A4E10	10"	25	250	420	5	60

DIN 3129 QUALITY STANDARDS

ANSI / ASME B107.2 QUALITY STANDARDS

SOCKETS SERIES

SOCKETS SERIES

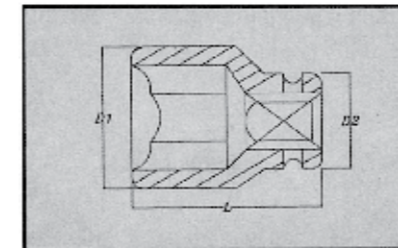
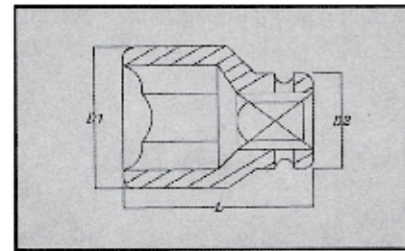

S03A6	3/4" DR. 6PT FLANK IMPACT SOCKETS (MM)						
		• DIN 3129 • CHROME MOLYBDENUM • PHOSPHATE COATING					

S03A6	3/4" DR. 6PT FLANK IMPACT SOCKETS (SAE)						
		• ANSI / ASME B107.2 • CHROME MOLYBDENUM • PHOSPHATE COATING					

ITEM NO.	SIZE (mm)	D1 (mm)	D2 (mm)	L (mm)	WEIGHT (g)	PACKING	
						INNER PC/BOX	OUTER PC/CTN
S03A6117	17	29.5	38	51	375	6	72
S03A6118	18	31.4	38	51	319	6	72
S03A6119	19	33.0	38	51	320	6	72
S03A6120	20	34.0	38	51	327	6	72
S03A6121	21	35.0	38	51	333	6	72
S03A6122	22	37.0	38	51	340	6	72
S03A6123	23	38.0	38	51	338	6	72
S03A6124	24	39.0	38	51	371	6	72
S03A6125	25	40.0	38	51	352	6	72
S03A6126	26	41.0	38	51	346	6	72
S03A6127	27	43.0	40	53	374	6	72
S03A6128	28	44.0	40	53	398	6	72
S03A6129	29	45.0	42	53	407	6	72
S03A6130	30	46.0	44	53	403	6	72
S03A6131	31	47.6	44	53	417	6	72
S03A6132	32	49.0	44	57	468	6	36
S03A6133	33	51.0	44	57	488	6	36
S03A6134	34	51.0	44	57	497	6	36
S03A6135	35	53.0	44	57	475	6	36
S03A6136	36	54.0	44	57	506	6	36
S03A6137	37	55.0	44	57	532	6	36
S03A6138	38	56.0	44	57	547	6	36
S03A6139	39	57.7	44	57	565	6	36
S03A6140	40	59.0	44	57	611	6	36
S03A6141	41	60.0	44	57	578	6	36
S03A6142	42	61.4	44	57	584	6	36
S03A6143	43	62.7	44	62	666	6	36
S03A6144	44	64.0	44	62	667	6	36
S03A6145	45	65.0	44	62	727	6	36
S03A6146	46	66.4	44	62	712	6	36
S03A6147	47	67.6	44	67	768	6	36
S03A6148	48	68.8	44	67	822	3	18
S03A6149	49	70.0	44	72	848	3	18
S03A6150	50	71.4	54	72	1058	3	18
S03A6151	51	72.8	54	72	1110	3	18
S03A6152	52	74.0	54	72	1190	3	18
S03A6153	53	75.0	54	72	1214	3	18
S03A6154	54	76.4	54	72	1244	3	18
S03A6155	55	77.7	54	74	1310	3	18
S03A6156	56	79.0	54	74	1279	3	18
S03A6157	57	80.0	54	74	1333	3	18
S03A6158	58	81.5	54	75	1435	3	18
S03A6159	59	82.7	54	75	1437	3	18
S03A6160	60	84.0	54	75	1435	3	18
S03A6163	63	87.6	54	75	1572	3	12
S03A6165	65	90.0	54	78	1655	3	12
S03A6167	67	92.7	54	80	1715	3	12
S03A6170	70	96.4	54	83	2094	3	12

ITEM NO.	SIZE (inch)	D1 (mm)	D2 (mm)	L (mm)	WEIGHT (g)	PACKING	
						INNER PC/BOX	OUTER PC/CTN
S03A6217	11/16"	30.6	44	51	318	6	72
S03A6219	3/4"	32.6	44	51	320	6	72
S03A6221	13/16"	34.7	44	51	275	6	72
S03A6222	7/8"	36.6	44	51	339	6	72
S03A6224	15/16"	38.9	44	51	347	6	72
S03A6226	1"	40.7	44	51	368	6	72
S03A6227	1-1/16"	42.6	44	53	374	6	72
S03A6229	1-1/8"	44.5	44	53	402	6	72
S03A6230	1-3/16"	46.4	44	53	403	6	72
S03A6232	1-1/4"	48.9	44	53	443	6	36
S03A6233	1-5/16"	50.6	44	56	420	6	36
S03A6235	1-3/8"	52.7	44	56	432	6	36
S03A6236	1-7/16"	54.6	44	57	500	6	36
S03A6238	1-1/2"	56.4	44	57	547	6	36
S03A6240	1-9/16"	58.9	44	57	596	6	36
S03A6241	1-5/8"	60.1	44	57	571	6	36
S03A6243	1-11/16"	62.7	44	62	666	6	36
S03A6244	1-3/4"	64.5	44	62	687	6	36
S03A6246	1-13/16"	66.4	44	62	712	6	36
S03A6248	1-7/8"	68.8	44	62	822	3	18
S03A6249	1-15/16"	70.2	44	62	848	3	18
S03A6251	2"	72.8	54	72	1110	3	18
S03A6253	2-1/16"	74.4	54	72	1168	3	18
S03A6254	2-1/8"	76.4	54	72	1244	3	18
S03A6256	2-3/16"	80.0	54	72	1279	3	18
S03A6257	2-1/4"	80.2	54	75	1333	3	18
S03A6259	2-5/16"	82.0	54	75	1455	3	18
S03A6260	2-3/8"	84.1	54	75	1435	3	18
S03A6263	2-1/2"	88.2	54	80	1545	3	12
S03A6265	2-9/16"	90.2	54	80	1655	3	12
S03A6267	2-5/8"	92.3	54	80	1715	3	12
S03A6270	2-3/4"	96.4	54	80	2094	3	12

DIN 3129 QUALITY STANDARDS

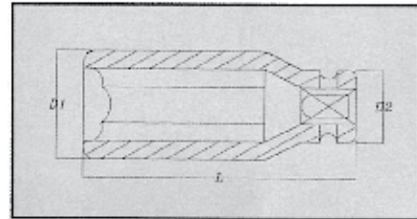

S03AD6		3/4" DR. 6PT FLANK DEEP IMPACT SOCKETS (MM)					
		<ul style="list-style-type: none"> • DIN 3129 • CHROME MOLYBDENUM • PHOSPHATE COATING 					

ITEM NO.	SIZE (mm)	D1 (mm)	D2 (mm)	L (mm)	WEIGHT (g)	PACKING	
						INNER PC/BOX	OUTER PC/CTN
S03AD6117	17	30.1	44	90	574	1	32
S03AD6118	18	31.4	44	90	588	1	32
S03AD6119	19	32.6	44	90	599	1	32
S03AD6120	20	33.8	44	90	611	1	32
S03AD6121	21	35.1	44	90	633	1	32
S03AD6122	22	36.6	44	90	642	1	32
S03AD6123	23	37.6	44	90	655	1	32
S03AD6124	24	38.9	44	90	637	1	32
S03AD6125	25	40.1	44	90	641	1	32
S03AD6126	26	41.3	44	90	645	1	32
S03AD6127	27	42.6	44	90	632	1	32
S03AD6128	28	44.0	44	90	639	1	32
S03AD6129	29	45.1	44	90	656	1	32
S03AD6130	30	46.4	44	90	679	1	32
S03AD6131	31	47.6	44	90	729	1	32
S03AD6132	32	48.9	44	90	736	1	32
S03AD6133	33	50.6	44	90	771	1	32
S03AD6134	34	51.4	44	90	788	1	32
S03AD6135	35	52.7	44	90	815	1	32
S03AD6136	36	53.9	44	90	840	1	32
S03AD6137	37	55.2	44	90	862	1	32
S03AD6138	38	56.4	44	90	882	1	32
S03AD6140	40	58.9	44	90	910	1	18
S03AD6141	41	60.1	44	90	970	1	18
S03AD6142	42	61.4	44	90	1006	1	18
S03AD6143	43	62.7	44	90	1037	1	18
S03AD6146	46	66.4	44	90	1256	1	18
S03AD6149	49	70.2	44	90	1425	1	18
S03AD6150	50	71.4	54	90	1647	1	18

JONNESWAY

DIN 3121 QUALITY STANDARDS

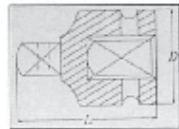

S03A6A		3/4" DR. ADAPTERS				
		<ul style="list-style-type: none"> • DIN 3121 • CHROME MOLYBDENUM 				

ITEM NO.	SIZE	D (mm)	L (mm)	WEIGHT (g)	PACKING	
					INNER PC/BOX	OUTER PC/CTN
S03A6A4	1/2"	44	58	330	12	72
S03A6A8	1"	44	63	410	6	48

JONNESWAY



S03A6U		3/4" DR. UNIVERSAL JOINT				
		<ul style="list-style-type: none"> • DIN 3121 • CHROME MOLYBDENUM 				

ITEM NO.	SIZE	D (mm)	L (mm)	WEIGHT (g)	PACKING	
					INNER PC/BOX	OUTER PC/CTN
S03A6U6	3/4"	44	105	750	6	24

JONNESWAY



S03A6E		3/4" DR. EXTENSION BARS				
		<ul style="list-style-type: none"> • DIN 3121 • CHROME MOLYBDENUM 				

ITEM NO.	SIZE	D (mm)	L (mm)	WEIGHT (g)	PACKING	
					INNER PC/BOX	OUTER PC/CTN
S03A6E35	3-1/2"	44	89	560	12	48
S03A6E04	4"	44	100	600	12	24
S03A6E06	6"	44	150	680	12	24
S03A6E07	7"	44	175	770	12	24
S03A6E08	8"	44	200	880	12	24
S03A6E10	10"	44	250	1030	12	20

ANSI / ASME B107.2 QUALITY STANDARDS

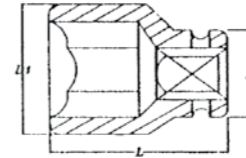

S03A8		1" DR. 6PT FLANK IMPACT SOCKETS (SAE)					
		<ul style="list-style-type: none"> • ANSI / ASME B107.2 • CHROME MOLYBDENUM • PHOSPHATE COATING 					

ITEM NO.	SIZE (SAE)	D1 (mm)	D2 (mm)	L (mm)	WEIGHT (g)	PACKING	
						INNER PC/BOX	OUTER PC/CTN
S03A8226	1"	43.7	54	58	553	1	36
S03A8229	1-1/8"	47.0	54	60	612	1	36
S03A8235	1-3/8"	55.0	54	62	692	1	36
S03A8238	1-1/2"	59.4	54	65	784	1	27
S03A8241	1-5/8"	63.1	54	65	846	1	27

JONNESWAY

DIN 3121 QUALITY STANDARDS

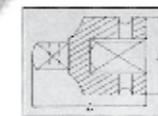

S03A8A		1" DR. ADAPTERS				
		<ul style="list-style-type: none"> • DIN 3121 • CHROME MOLYBDENUM 				

ITEM NO.	SIZE	D (mm)	L (mm)	WEIGHT (g)	PACKING	
					INNER PC/BOX	OUTER PC/CTN
S03A8A6	3/4"	54	75	660	1	10
S03A8A12	1-1/2"	54	90	960	1	10

JONNESWAY



S03A8U		1" DR. UNIVERSAL JOINT				
		<ul style="list-style-type: none"> • DIN 3121 • CHROME MOLYBDENUM 				

ITEM NO.	SIZE	D (mm)	L (mm)	WEIGHT (g)	PACKING	
					INNER PC/BOX	OUTER PC/CTN
S03A8U8	1"	54	130	1380	1	10

JONNESWAY

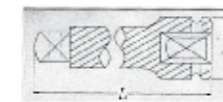

S03A8E		1" DR. EXTENSION BARS				
		<ul style="list-style-type: none"> • DIN 3121 • CHROME MOLYBDENUM 				

ITEM NO.	SIZE	D (mm)	L (mm)	WEIGHT (g)	PACKING	
					INNER PC/BOX	OUTER PC/CTN
S03A8E04	1"	54	100(4")	1000	2	20
S03A8E06	1"	54	150(6")	1200	2	20
S03A8E07	1"	54	175(7")	1350	2	20
S03A8E08	1"	54	200(8")	1580	1	18
S03A8E10	1"	54	250(10")	1960	1	10
S03A8E12	1"	54	300(12")	2150	1	10
S03A8E13	1"	54	330(13")	2240	1	10

DIN 3121 QUALITY STANDARDS

SOCKETS SERIES



S05A408S	8PCS 1/2" DR. HEX BIT IMPACT SOCKET SET
-----------------	--

CONTENTS:

S05A4	8PCS-1/2" DR. HEX BIT IMPACT SOCKETS : H5, H6, H8, H10, H12, H14, H17, H19
PACKING	BLOW CASE + COLOR BOX 20SETS/CTN/24KGS/25KGS/1.5'

JONNESWAY



1/2"



S06A408S	8PCS 1/2" DR. STAR BIT IMPACT SOCKET SET
CONTENTS: T30, T40, T45, T50, T55, T60, T70, T80	

CONTENTS:

S06A4	8PCS-1/2" DR. STAR BIT IMPACT SOCKETS : T30, T40, T45, T50, T55, T60, T70, T80 (L:78MM)
PACKING	BLOW CASE + COLOR BOX 20SETS/CTN/21KGS/22KGS/1.5'

JONNESWAY

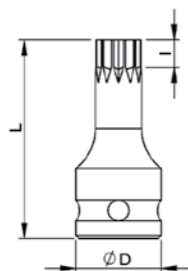

S16A45	1/2"DR. SPLINE BIT IMPACT SOCKET
---------------	---

ITEM NO.	SIZE	D (mm)	I (mm)	L (mm)
S16A4506	M6	25	6.0	100
S16A4508	M8	25	8.0	100
S16A4510	M10	25	8.5	100
S16A4512	M12	25	9.0	100
S16A4514	M14	25	9.5	100
S16A4516	M16	25	10.0	100
S16A4518	M18	25	11.0	100

DIN 3121 QUALITY STANDARDS

SOCKETS SERIES



- * Different colors for sizes
- * Plastic ring to protect aluminum alloy wheel cover.
- * Chrome molybdenum steel

JONNESWAY

S03AD43	1/2" DR. 6PT FLANK THIN WALL DEEP IMPACT SOCKET
----------------	--

ITEM NO.	SIZE (mm)	D (mm)	L (mm)	WEIGHT (g)	PACKING	
					INNER PC/BOX	OUTER PC/CTN
S03AD4317	17	24	85	200	8	48
S03AD4319	19	26	85	210	8	48
S03AD4321	21	28	85	220	8	48



S03AD4303S	3PCS 1/2" DR. 6PT FLANK THIN WALL DEEP IMPACT SOCKET SET
-------------------	---

CONTENTS:

S03AD43	3PCS-1/2" DR. 6PT FLANK THIN WALL DEEP IMPACT SOCKETS : 17, 19, 21MM
PACKING	BLOW CASE + COLOR SLEEVE 24SETS/CTN/20.4KGS/21.4KGS/1.1'

JONNESWAY



S18A	1/2"DR. WHEEL NUT IMPACT DEEP SOCKET
-------------	---

ITEM NO.	SIZE	D (mm)	L (mm)	WEIGHT (g)	COLOR
S18A4117	17	27	85	219	BLUE
S18A4119	19	28.5	85	248	GREEN
S18A4121	21	31	85	272	RED

JONNESWAY



AFTER LOOSENING, THE SCREW WILL STICK ON THE INSIDE OF MAGNETIC, WITHOUT FALLING OFF.

S18A4M	1/2"DR. WHEEL NUT IMPACT DEEP SOCKET (MAGNETIC)
---------------	--

ITEM NO.	SIZE	D (mm)	L (mm)	WEIGHT (g)	COLOR
S18A4117M	17	27	85	220	BLUE
S18A4119M	19	28.5	85	233	GREEN
S18A4121M	21	31	85	252	RED



PLIERS SERIES

- Chrome Vanadium Steel
- CR-MO Handles for Locking Pliers
- Precision Forged
- Ergonomic Grip Designs

JONNESWAY PROFESSIONAL PLIERS

- 1.CR-V Steel
- 2.Precision Forged
- 3.Polish Finished



JONNESWAY

ITEM	L (inch)	L (mm)	WEIGHT (g)	PACKING	
				INNER PC/BOX	OUTER PC/CTN
P086	6"	160	250	12	72
P087	7"	180	310	12	60
P088	8"	200	410	12	60



JONNESWAY

ITEM	L (inch)	L (mm)	WEIGHT (g)	PACKING	
				INNER PC/BOX	OUTER PC/CTN
P097	7"	180	280	12	72
P098	8"	200	300	12	60



JONNESWAY

ITEM	L (inch)	L (mm)	WEIGHT (g)	PACKING	
				INNER PC/BOX	OUTER PC/CTN
P106	6"	160	240	12	60
P107	7"	180	270	12	72



ITEM	L (inch)	L (mm)	WEIGHT (g)	PACKING	
				INNER PC/BOX	OUTER PC/CTN
P116	6"	160	180	12	72
P118	8"	200	260	12	60

JONNESWAY PROFESSIONAL PLIERS

1. Hardness 60 - 64 degrees on cutting edge because of special " high frequency " heat treatment. Cutting edges remain very sharp after multiple operation on hard materials.
2. Precision compact junction on cutting edge.
3. Patented design of off-center for saving manual power.



JONNESWAY

P01		SIDE CUTTING PLIERS				
ITEM	L (inch)	L (mm)	MAX CAPACITY DIA. (mm)	WEIGHT (g)	PACKING	
					INNER PC/BOX	OUTER PC/CTN
P017	7"	190	∅3.2	248	6	60
P018	8"	212	∅3.5	342	6	60



JONNESWAY

P08A		LINESMEN'S PLIERS				
ITEM	L (inch)	L (mm)	WEIGHT (g)	PACKING		
				INNER PC/BOX	OUTER PC/CTN	
P086A	6"	163	200	12	72	
P087A	7"	194	310	12	60	
P088A	8"	224	410	12	60	



JONNESWAY

P028		8" PATENTED WIRE CUTTERS GERMAN PATENT NO. M94028540				
ITEM	L (inch)	L (mm)	MAX CAPACITY DIA. (mm)	WEIGHT (g)	PACKING	
					INNER PC/BOX	OUTER PC/CTN
P028	8"	202	∅4.0	275	6	60

JONNESWAY PROFESSIONAL PLIERS

1. Hardness 47 - 59 degrees on cutting edge because of special " high frequency " heat treatment. Cutting edges remain very sharp after multiple operation on hard materials.
2. Precision compact junction on cutting edge.
3. Patented design of off-center for saving manual power.



JONNESWAY

P038		8" DIAGONAL CUTTING PLIERS				
ITEM	L (inch)	L (mm)	MAX CAPACITY DIA. (mm)	WEIGHT (g)	PACKING	
					INNER PC/BOX	OUTER PC/CTN
P038	8"	197	2.0~3.0	270	6	60



JONNESWAY

P09A		HEAVY DUTY DIAGONAL CUTTING PLIERS				
ITEM	L (inch)	L (mm)	WEIGHT (g)	PACKING		
				INNER PC/BOX	OUTER PC/CTN	
P097A	7"	190	240	12	72	



JONNESWAY

P046		6" DIAGONAL CUTTING PLIERS				
ITEM	L (inch)	L (mm)	MAX CAPACITY DIA. (mm)	WEIGHT (g)	PACKING	
					INNER PC/BOX	OUTER PC/CTN
P046	6"	160	1.8~2.0	155	6	60



JONNESWAY

P068		8" LONG NOSE PLIERS				
ITEM	L (inch)	L (mm)	MAX CAPACITY DIA. (mm)	WEIGHT (g)	PACKING	
					INNER PC/BOX	OUTER PC/CTN
P068	8"	200	2.5	180	6	60



JONNESWAY

P06A		LONG NOSE W/SIDE CUTTER PLIERS				
ITEM	L (inch)	L (mm)	WEIGHT (g)	PACKING		
				INNER PC/BOX	OUTER PC/CTN	
P066A	6"	167	130	12	96	
P068A	8"	200	180	12	60	



JONNESWAY

P60		SLIP JOINT PLIERS				
ITEM	L (inch)	L (mm)	WEIGHT (g)	PACKING		
				INNER PC/BOX	OUTER PC/CTN	
P6006	6"	160	180	12	96	
P6008	8"	200	290	12	72	

JONNESWAY PROFESSIONAL PLIERS

- 1.CR-V Steel
- 2.Precision Forged
- 3.Polish Finished



P6210 9-3/4" CRIMPING TOOL

ITEM	L (inch)	L (mm)	WEIGHT (g)	PACKING	
				INNER PC/BOX	OUTER PC/CTN
P6210	9-3/4"	240	340	6	60

JONNESWAY



P27 MACHINED TONGUE & GROOVE WATER PUMP PLIERS

ITEM	L (inch)	L (mm)	WEIGHT (g)	PACKING	
				INNER PC/BOX	OUTER PC/CTN
P2708	8"	200	340	12	72
P2710	10"	250	400	12	60

JONNESWAY



P28 BOX JOINT PLIERS

ITEM	L (inch)	L (mm)	WEIGHT (g)	PACKING	
				INNER PC/BOX	OUTER PC/CTN
P2810	10"	250	430	12	60

- *BLACK FINISHED
- *CR-V STEEL, DROP FORGED HEAT TREATMENT

JONNESWAY



P7719 9" WIRE TWISTING PLIERS

ITEM NO.	SIZE (inch)	L (mm)	CAPACITY (mm)	WEIGHT (g)	PACKING	
					INNER PC/BOX	OUTER PC/CTN
P7719	9"	270	Ø0.55 stainless	360	1	50



P7601 11" LONG PLIERS

ITEM	ANGLE	INCH	METRIC (mm)	WEIGHT (g)	INNER PC / BOX	OUTER PC / CTN
P7601	0 DEGREE	11"	275	330	12	60

* A combination of the 80mm extended shanks and the 90 degrees angled gripping jaws provides easy access to low-lying work areas, minimizing the risk of accidental burns on the hand while working on a hot engine block.

JONNESWAY



P7602 11" LONG PLIERS

ITEM	ANGLE	INCH	METRIC (mm)	WEIGHT (g)	INNER PC / BOX	OUTER PC / CTN
P7602	45 DEGREE	11"	275	330	12	60

* A combination of the 80mm extended shanks and the 90 degrees angled gripping jaws provides easy access to low-lying work areas, minimizing the risk of accidental burns on the hand while working on a hot engine block.

JONNESWAY



P7603 11" END CUTTING PLIERS

ITEM	ANGLE	INCH	METRIC (mm)	WEIGHT (g)	INNER PC / BOX	OUTER PC / CTN
P7603	90 DEGREE	11"	275	330	12	60

* A combination of the 80mm extended shanks and the 90 degrees angled gripping jaws provides easy access to low-lying work areas, minimizing the risk of accidental burns on the hand while working on a hot engine block.

JONNESWAY



P7609 11" EXTRA LONG ROUND JAWS PLIERS DIA 19MM (3/4")

ITEM NO.	DIA.	LENGTH INCH	WEIGHT (g)	INNER PC / BOX	OUTER PC / CTN
P7609	19mm (3/4")	11"	330	12	60

- Made from CR-MO material.
- Suitable for using on hoses, spark plug wires, etc....

JONNESWAY



P5602 4" SIDE CUTTER PLIERS

ITEM	L (inch)	L (mm)	WEIGHT (g)	PACKING	
				INNER PC/BOX	OUTER PC/CTN
P5602	4"	100	8	6	120

- FOR WIRES BELOW 1.0MM.
- THIN CUTTING JAWS.
- ABLE TO STRIP WIRE.

JONNESWAY



P5603 5" SIDE CUTTER PLIERS

ITEM	L (inch)	L (mm)	WEIGHT (g)	PACKING	
				INNER PC/BOX	OUTER PC/CTN
P5603	5"	125	13	6	120

- SUITABLE FOR SOFT WIRE BELOW DIA. 1.6MM
- DO NOT USE TO CUT STEEL WIRE.

JONNESWAY



P5605 5" SNIP NOSE PLIERS

ITEM	L (inch)	L (mm)	WEIGHT (g)	PACKING	
				INNER PC/BOX	OUTER PC/CTN
P5605	5"	125	10	6	120

- WITH CUTTER.
- SERRATED FOR EASY TAKING UP.



P7104 MINIATURE LINEMAN'S PLIERS											
ITEM NO.	L	L3	W3	W4	T1	WEIGHT (g)	CUTTING WIRE φ mm	Tensile Strength (MPA)	PACKING		
P7104	120	15.8	13.6	4	8.2	90	1.25	1241	6	72	

- Ergonomic design for comfortable grip.
- Spring loaded.
- Lay-on joint.
- Meeting standard cutting & loading test.
- Chrome nickel steel drop forged for hardened cutting edges.
- Serrated jaws.

JONNESWAY

2 COLOR SANTOPRENE HANDLES



JONNESWAY

P32MC CURVED JAW LOCKING PLIERS WITH WIRE CUTTER				
ITEM NO.	SIZE (inch)	WEIGHT (g)	PACKING	
			INNER PC/BOX	OUTER PC/CTN
P32M10C	10"	560	6	36
P32M07C	7"	330	6	72
P32M05C	5"	175	6	72



P32M CURVED JAW LOCKING PLIERS WITH WIRE CUTTERS				
ITEM NO.	SIZE (inch)	WEIGHT (g)	PACKING	
			INNER PC/BOX	OUTER PC/CTN
P32M10A	10"	560	6	36
P32M07A	7"	330	6	72
P32M05A	5"	175	6	72

JONNESWAY



JONNESWAY

P30M STRAIGHT JAW LOCKING PLIERS				
ITEM NO.	SIZE (inch)	WEIGHT (g)	PACKING	
			INNER PC/BOX	OUTER PC/CTN
P30M10C	10"	540	6	36
P30M07C	7"	360	6	72



JONNESWAY

P30M STRAIGHT JAW LOCKING PLIERS				
ITEM NO.	SIZE (inch)	WEIGHT (g)	PACKING	
			INNER PC/BOX	OUTER PC/CTN
P30M10A	10"	540	6	36
P30M07A	7"	360	6	72



JONNESWAY

P36MC LONG NOSE LOCKING PLIERS WITH WIRE CUTTER				
ITEM NO.	SIZE (inch)	WEIGHT (g)	PACKING	
			INNER PC/BOX	OUTER PC/CTN
P36M09C	9"	360	6	36
P36M06C	6"	180	6	72



JONNESWAY

P36M LONG NOSE LOCKING PLIERS WITH WIRE CUTTERS				
ITEM NO.	SIZE (inch)	WEIGHT (g)	PACKING	
			INNER PC/BOX	OUTER PC/CTN
P36M09A	9"	360	6	36



JONNESWAY

P38M WELDING CLAMPS				
ITEM NO.	SIZE (inch)	WEIGHT (g)	PACKING	
			INNER PC/BOX	OUTER PC/CTN
P38M11A	11"	650	1	40



JONNESWAY

P52M LOCKING PLIERS				
ITEM NO.	SIZE (inch)	WEIGHT (g)	PACKING	
			INNER PC/BOX	OUTER PC/CTN
P52M10	10"	520	6	36

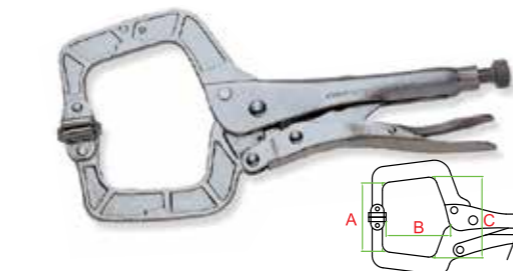

JONNESWAY

P53M LONG LOCKING C-CLAMP WITH PAD								
ITEM NO.	SIZE (inch)	JAW OPENING WIDTH (mm)	WEIGHT (g)	PACKING		A (mm)	B (mm)	C (mm)
				INNER PC/BOX	OUTER PC/CTN			
P53M11	11"	0-90 mm	730	10	30	85	70	95



P32M03S 3PCS LOCKING PLIERS SET	
ITEM NO.	DESCRIPTION
P36M06A	6" LONG NOSE LOCKING PLIERS WITH WIRE CUTTER
P32M07A	7" CURVED JAW LOCKING PLIERS WITH WIRE CUTTER
P32M10A	10" CURVED JAW LOCKING PLIERS WITH WIRE CUTTER



P54M SHEET METAL LOCKING PLIERS				
ITEM NO.	SIZE (inch)	WEIGHT (g)	PACKING	
			INNER PC/BOX	OUTER PC/CTN
P54M10A	10"	650	1	48

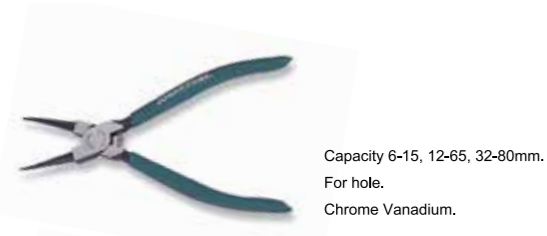

Capacity 6-15, 12-65, 32-80mm.
For hole.
Chrome Vanadium.

AG010001	5"(125MM) STRAIGHT NOSE, INTERNAL PLIERS
AG010002	7"(175MM) STRAIGHT NOSE, INTERNAL PLIERS
AG010003	9"(230MM) STRAIGHT NOSE, INTERNAL PLIERS

JONNESWAY

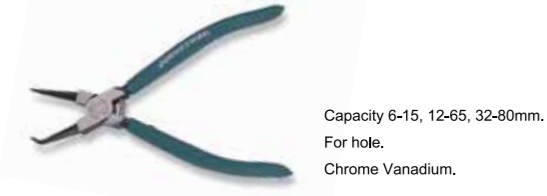

Capacity 6-15, 12-65, 32-80mm.
For hole.
Chrome Vanadium.

AG010005	7"(175MM) BENT NOSE, INTERNAL PLIERS
AG010006	9"(230MM) BENT NOSE, INTERNAL PLIERS

JONNESWAY



Capacity 3-15, 10-40, 32-80mm.
For shaft.
Chrome Vanadium.

AG010008	7"(175MM) STRAIGHT NOSE, EXTERNAL PLIERS
AG010009	9"(230MM) STRAIGHT NOSE, EXTERNAL PLIERS

JONNESWAY



Capacity 3-15, 10-40, 32-80mm.
For shaft.
Chrome Vanadium.

AG010011	7"(175MM) BENT NOSE, EXTERNAL PLIERS
AG010012	9"(230MM) BENT NOSE, EXTERNAL PLIERS

JONNESWAY



P9920A	20" (500MM) STRAIGHT NOSE, INTERNAL PLIERS
P9920AS	20" (500MM) STRAIGHT NOSE, INTERNAL PLIERS W/BENT TIPS

ITEM NO.	L (inch)	L (mm)	WEIGHT (g)	PACKING	
				INNER PC/BOX	OUTER PC/CTN
P9920A	20"	508	1652	1	12

- Using For Large Vehicle Building / repair
- Capacity : 165~300mm
- For Hole : 4.5 ~ 5.5mm

Internal

JONNESWAY

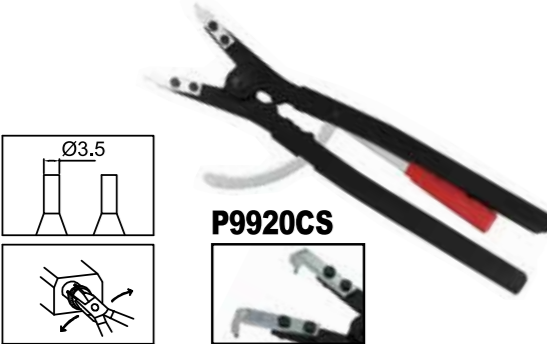

P9920C	20" (500MM) STRAIGHT NOSE, EXTERNAL PLIERS
P9920CS	20" (500MM) STRAIGHT NOSE, EXTERNAL PLIERS W/BENT TIPS

ITEM NO.	L (inch)	L (mm)	WEIGHT (g)	PACKING	
				INNER PC/BOX	OUTER PC/CTN
P9920C	20"	508	1669	1	12

- Using For Large Vehicle Building / repair
- Capacity : 165 - 300mm
- For Hole : 4.5 -5.5mm

External

JONNESWAY



JONNESWAY

V1401	PROFESSIONAL CRIMPING TOOL & WIRE STRIPPER
	-MULTI-PURPOSE. QUICK & EASY WORK •10~22 AWG



JONNESWAY

V1402	PROFESSIONAL CRIMPING TOOL & WIRE STRIPPER
FEATURES	• MULTI-PURPOSE (8 IN 1) QUICK & EASY WORK • PAT
PACKING	SLIDE CARD 50SETS/CTN/13KGS/14KGS/1.2'



JONNESWAY

V1501	HEAVY DUTY EASY STRIPPER
FEATURES	• CRIMPED TYPE OF TERMINAL • INSULATED TERMINALS • NON-INSULATED TERMINAL • AUTO IGNITION TERMINAL • LENGTH : 205MM • WEIGHT : 305G
PACKING	SLIDE CARD 60SETS/CTN/20KGS/21KGS/1.8'



JONNESWAY

V1503	HEAVY DUTY EASY STRIPPER
	• LENGTH : 172MM • WEIGHT : 245G
PACKING	SLIDE CARD 60SETS/CTN/17KGS/18KGS/1.4'



JONNESWAY

V1001	HEAVY DUTY HAND RIVETER
FEATURES	• DROP FORGE HANDLE, ALUMINUM BODY • TUV + GS APPROVAL • JAWS MADE OF SCM 4
EQUIPPED	4 NOSE PIECES : 2.4MM (3/32"), 3.2MM (1/8"), 4.0MM (5/32"), 4.8MM (3/16")
PACKING	SLIDE CARD 24SETS/CTN/14KGS/15KGS/1'



JONNESWAY

V1002	SCISSOR ACTION INDUSTRIAL RIVETER
FEATURES	• MADE OF DURABLE HIGH CARBON STEEL
EQUIPPED	4 NOSE PIECES : 2.4MM (3/32"), 3.2MM (1/8"), 4.0MM (5/32"), 4.8MM (3/16")
PACKING	COLOR BOX 10SETS/CTN/20KGS/21KGS/1.4'



V1004	FREE SUCTION HAND RIVETER
FEATURES	• HEAD ROTATES 360° FOR ANY ANGLE RIVETING
EQUIPPED	4 NOSE PIECES : 2.4MM (3/32"), 3.2MM (1/8"), 4.0MM (5/32"), 4.8MM (3/16")
PACKING	SLIDE CARD 24SETS/CTN/14KGS/15KGS/1.5'



P19A OFFSET TIN SNIPS (L/R) CR-MO

- Drop forged CR-MO steel blades
- Hardened serrated edges of HRC55-60
- Hardened cutting edges of HRC60-62
- Cutting capacity up to 1.2mm cold rolled steel or 0.7mm stainless steel

ITEM	L (inch)	L (mm)	WEIGHT (g)	PACKING	
				INNER PC/BOX	OUTER PC/CTN
P199LA	9-3/4"	240	395	6	48
P199RA	9-3/4"	240	395	6	48

JONNESWAY



P20A AVIATION TIN SNIPS CR-MO

- Drop forged CR-MO steel blades
- Hardened serrated edges of HRC55-60
- Hardened cutting edges of HRC60-62
- Cutting capacity up to 1.2mm cold rolled steel or 0.7mm stainless steel

ITEM	L (inch)	L (mm)	WEIGHT (g)	PACKING	
				INNER PC/BOX	OUTER PC/CTN
P2010SA	10"	250	395	6	48

JONNESWAY



P22A STRAIGHT PATTERN SNIPS

- DROP FORGED
- HIGH CARBON STEEL

- Designed for all straight cutting including inside and outside corners
- Drop forged
- Induction hardened HRC 55-60

ITEM	L (inch)	L (mm)	WEIGHT (g)	PACKING	
				INNER PC/BOX	OUTER PC/CTN
P2207A	7"	180	266	10	60
P2208A	8"	205	316	6	36
P2210A	10"	254	472	6	36
P2212A	12"	305	645	6	24

- P2207A** 7" Cuts up to 0,56mm cold rolled steel of 0,38mm stainless steel
- P2208A** 8" Cuts up to 0,61mm cold rolled steel of 0,41mm stainless steel
- P2210A** 10" Cuts up to 0,78mm cold rolled steel of 0,45mm stainless steel
- P2212A** 12" Cuts up to 0,91mm cold rolled steel of 0,71mm stainless steel

JONNESWAY



P266 COMBINATION INTERNAL - EXTERNAL SNAP RING PLIERS

ITEM	L (inch)	L (mm)	WEIGHT (g)	PACKING	
				INNER PC/BOX	OUTER PC/CTN
P266	6"	150	200	12	72

- Internal limits 3/8" (12mm) - 2" (50mm)
- External limits 1/4" (6mm) - 2" (50mm)
- Use with either internal or external retaining rings With 4 pieces convertible tips.
- 1 piece 90° angle tip
- 1 piece 45° angle tip
- 2 pieces straight tip (1.50 & 1.20)

- *Each displayed with double tray on card
- *Each in plastic case then on sliding card
- *Each in plastic case with hanging hole & shrink



- * The material of body & blade are chrome vanadium and hot drop-forged with heat treatment.
- * Serrated cutting edges are heat-treated which can easily and firmly grip bolt and cost-saving on labor.
- * Three cutting functions in one which including bolt, wire and cable.
- * Thick & ergonomic TPR handle grip.



P43 BOLT & WIRE & CABLE 3 IN 1 CUTTERS

- SERRATED BLADE

ITEM NO	L (inch)	CUTTING CAPACITY ϕ m/m				WEIGHT (kg)	PACKING	
		BOLT		WIRE	CABLE		INNER PC/BOX	OUTER PC/CTN
		Soft Metals	Medium Metals					
P4309	9"	3(1/8")	3(1/8")	2(3/32")	5(3/16")	0.4	6	60
P4314	14"	7(1/4")	5(3/16")	3.2(1/8")	8(5/16")	1.015	1	20
P4318	18"	8(5/16")	6(1/4")	5(3/16")	10(3/8")	1.57	1	12
P4324	24"	10(3/8")	8(5/16")	7(9/32")	12(15/32")	2.68	1	10
P4330	30"	13(1/2")	8(5/16")	9(3/8")	14(9/16")	4.2	1	6
P4336	36"	16(5/8")	10(3/8")	12.7(1/2")	17(11/18")	6.34	1	5



JONNESWAY

- * Drop-forged blades with chrome molybdenum steel
- * Micro finished blades
- * Thick & ergonomic TPR handle grip



P55 BOLT CUTTERS

ITEM NO	SIZE	CUTTING CAPACITY ϕ m/m	WEIGHT (kg)	PACKING	
				INNER PC/BOX	OUTER PC/CTN
P5514	14"(350mm)	7	1.03	1	20
P5518	18"(450mm)	8	1.58	1	20
P5536	36"(900mm)	15	6.15	1	5



JONNESWAY

- * Drop-forged blades with chrome vanadium steel
- * High tensile
- * Thick & ergonomic TPR handle grip



28° angle

P64 ANGLE BOLT CUTTERS

ITEM NO	SIZE	CUTTING CAPACITY ϕ m/m	WEIGHT (kg)	PACKING	
				INNER PC/BOX	OUTER PC/CTN
P6424	24"(600mm)	10	2.7	1	10
P6436	36"(900mm)	15	6.5	1	5



- ANTI ELECTRO-SHOCK
- HANDLE INSULATION MEETS ALL REQUIRMENTS OF THE VDE STANDARD RELEVANT INTERNATIONAL STANDARDS(IEC 60900).



PV018 INSULATED HI-LEVERAGE COMBINATION PLIERS				
ITEM NO.	L (INCH)	L (MM)	WEIGHT (G)	INNER (PC/BOX)
PV018	8-1/2"	215	460	6

JONNESWAY



PV08 INSULATED COMBINATION PLIERS				
ITEM NO.	L (INCH)	L (MM)	WEIGHT (G)	INNER (PC/BOX)
PV086	6"	160	250	6
PV087	7"	180	300	6
PV088	8"	200	375	6

JONNESWAY



PV06 INSULATED BENT NOSE PLIERS				
ITEM NO.	L (INCH)	L (MM)	WEIGHT (G)	INNER (PC/BOX)
PV066	6"	160	185	6
PV068	8"	200	290	6

JONNESWAY



PV11 INSULATED LONG NOSE PLIERS				
ITEM NO.	L (INCH)	L (MM)	WEIGHT (G)	INNER (PC/BOX)
PV1106	6"	160	185	6

JONNESWAY

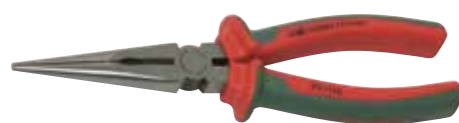

PV111 INSULATED LONG NOSE PLIERS						
ITEM NO.	L (mm)	○ mm	◐ mm	● mm	● mm	WEIGHT (g)
PV1118	200	4.0	3.0	2.0	1.6	250

- ANTI ELECTRO-SHOCK
- HANDLE INSULATION MEETS ALL REQUIRMENTS OF THE VDE STANDARD RELEVANT INTERNATIONAL STANDARDS(IEC 60900).



PV106 INSULATED DIAGONAL CUTTING PLIERS				
ITEM NO.	L (INCH)	L (MM)	WEIGHT (G)	INNER (PC/BOX)
PV106	6"	160	240	6

JONNESWAY



PV2810 INSULATED WATER PUMP PLIERS				
ITEM NO.	L (INCH)	L (MM)	WEIGHT (G)	INNER (PC/BOX)
PV2810	10"	250	280	6

JONNESWAY



PV156 INSULATED WIRE STRIPPING PLIERS					
ITEM NO.	L (INCH)	L (MM)	WEIGHT (G)	INNER (PC/BOX)	MAX CAPACITY
PV156	6"	160	190	6	4.5mm ²

JONNESWAY



PV0510 INSULATED HEAVY DUTY CABLE CUTTER					
ITEM NO.	L (INCH)	L (MM)	WEIGHT (G)	INNER (PC/BOX)	CAPACITY
PV0510	10"	250	530	6	φ 13mm/60mm ²

JONNESWAY



PV05 INSULATED CABLE CUTTER					
ITEM NO.	L (INCH)	L (MM)	WEIGHT (G)	INNER (PC/BOX)	CAPACITY
PV0506	6"	160	180	6	φ 9mm/60mm ²
PV0508	8"	200	300	6	φ 11mm/38mm ²

- ANTI ELECTRO-SHOCK
- HANDLE INSULATION MEETS ALL REQUIRMENTS OF THE VDE STANDARD RELEVANT INTERNATIONAL STANDARDS(IEC 60900).



JONNESWAY



JONNESWAY



JONNESWAY



DV13 1000V INSULATED SCREWDRIVERS GS & VDE APPROVED

ITEM NO.	SIZE	BLADE (mm)	GRIP (mm)	L (mm)
DV13S275	2.5	75	98	173
DV13S3100	3.0	100	98	198
DV13S4100	4.0	100	98	198
DV13S5125	5.5	125	104	229
DV13S6150	6.5	150	110	260
DV13S8175	8.0	175	120	295
DV13P060	PH0	60	98	158
DV13P180	PH1	80	104	184
DV13P2100	PH2	100	110	210
DV13P3150	PH3	150	120	270

DV13PP07S 7PCS 1000V INSULATED SCREWDRIVER SET

CONTENTS:

DV13S	3PCS-SLOTTED INSULATED SCREWDRIVERS : 4.0X100, 5.5X125, 6.5X150 (mm)
DV13P	3PCS-PHILLIPS INSULATED SCREWDRIVERS : PH0X60, PH1X80, PH2X100 (mm)
DV13PP-TP	1PC-"GS" TESTER PEN 220-250V

DV41M06S 6PCS 1000V INSULATED NUT DRIVERS SET

CONTENTS:

DV41	6PCS-M5, M6, M7, M8, M10, M13
------	-------------------------------

D02AP08S 8PCS 1000V INSULATED SCREWDRIVER SET (GS & VDE APPROVED)

- ACETATE PLASTICS HANDLE
- CHROME VANADIUM STEEL

CONTENTS:

D02S	4PCS-SLOTTED SCREWDRIVERS : 0.4x 2.5x 85, 0.8x 4.0x100, 1.0x5.5x125, 1.2x6.5x150MM
D02P	3PCS-PHILLIPS SCREWDRIVERS : PH0x75, PH1x100, PH2x100
	1PC-ELECTRIC TESTER : 220V-250V
PACKING	BLOW CASE + COLOR BOX 12SETSCTN/15KGS/16KGS/1.9'



SCREWDRIVER SERIES

- Chrome Vanadium Steel
- Professional Quality: ANSI / DIN Standards
- CR-MO Blades
- Comfort-Design Grips

**Santoprene Comfort Grip
With Pressure, Oil and Acid
Resistance**

SCREWDRIVER SERIES



D71P		ANTI - SLIP GRIP SCREWDRIVER - PHILLIPS					
<ul style="list-style-type: none"> • BLADES HARDENED SATIN FINISHED WITH MAGNETIC BLACK TIP • DIN 5262 • STRONG MAGNETIC 							

ITEM NO.	SIZE	SHANK DIA. (mm)	L1 (mm)	L2 (mm)	L (mm)	PACKING	
						INNER PC/BOX	OUTER PC/CTN
D71P060	PH0	3	60	90	150	12	144
D71P138	PH1	5	38	56	93	12	144
D71P175	PH1	5	75	110	185	12	144
D71P180	PH1	5	80	110	190	12	144
D71P1100	PH1	5	100	110	210	12	144
D71P1150	PH1	5	150	110	250	12	144
D71P238	PH2	6	38	56	94	12	144
D71P2100	PH2	6	100	119	219	12	144
D71P2200	PH2	6	200	119	269	12	144
D71P2150	PH2	6	150	119	369	12	72
D71P2250	PH2	6	250	119	419	12	72
D71P2300	PH2	6	300	120	320	12	72
D71P3125	PH3	8	125	129	254	12	72
D71P3150	PH3	8	150	129	279	12	72
D71P4200	PH4	10	200	129	329	12	72

JONNESWAY

D71S		ANTI - SLIP GRIP SCREWDRIVER - SLOTTED					
<ul style="list-style-type: none"> • BLADES HARDENED SATIN FINISHED WITH MAGNETIC BLACK TIP • DIN 5262 • STRONG MAGNETIC 							

ITEM NO.	SIZE	SHANK DIA. (mm)	L1 (mm)	L2 (mm)	L (mm)	PACKING	
						INNER PC/BOX	OUTER PC/CTN
D71S250	2.4	2.4	50	72	122	12	144
D71S360	3	3	60	72	132	12	144
D71S480	4	4	80	90	170	12	144
D71S4200	4	4	200	90	290	12	144
D71S538	5.5	5	38	56	94	12	144
D71S575	5.5	5	75	110	185	12	144
D71S5125	5.5	5	125	110	235	12	144
D71S5150	5.5	5	150	110	260	12	144
D71S5200	5.5	5	200	110	310	12	144
D71S5250	5.5	5	250	110	360	12	144
D71S5300	5.5	5	300	110	410	12	144
D71S638	6.5	6	38	56	94	12	144
D71S6100	6.5	6	100	119	219	12	144
D71S6150	6.5	6	150	119	269	12	144
D71S8150	8	7	150	129	279	12	72
D71S8175	8	7	175	129	304	12	72
D71S8200	8	7	200	129	329	12	72
D71S8250	8	7	250	129	379	12	72
D71S9175	9.5	8	175	129	304	12	72

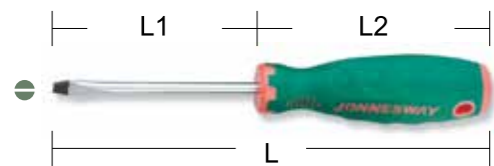

JONNESWAY



D71PP08S		8PCS ANTI-SLIP GRIP SCREWDRIVER SET					
----------	--	-------------------------------------	--	--	--	--	--

CONTENTS:							
D71S	4PCS-SLOTTED SCREWDRIVERS : 6.5x38, 4x80, 5.5x125, 6.5x150MM						
D71P	4PCS-PHILLIPS SCREWDRIVERS : PH2x38, PH1x80, PH2x100, PH3x150						
PACKING	BLOWING CASE + COLOR BOX 12SETS/CTN/10KGS/11KGS/1.9"						

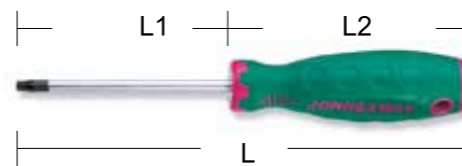

JONNESWAY



JONNESWAY

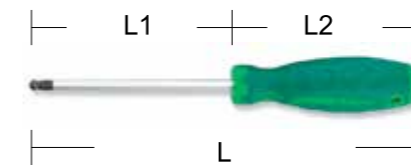

JONNESWAY



JONNESWAY

D71T		ANTI-SLIP GRIP STAR SCREWDRIVERS					
<ul style="list-style-type: none"> • STRONG MAGNETIC TIP • CHROME SILICIUM VANADIUM STEEL • DIN 50150 							

ITEM NO.	SIZE	SHANK DIA. (mm)	L1 (mm)	L2 (mm)	L (mm)
D71T5	T5	3	60	72	132
D71T6	T6	3	60	72	132
D71T7	T7	3	60	72	132
D71T8	T8	3	60	72	132
D71T9	T9	3	60	72	132
D71T10	T10	4	80	90	170
D71T15	T15	4	80	90	170
D71T20	T20	5	100	110	210
D71T25	T25	5	100	110	210
D71T27	T27	6	100	119	219
D71T30	T30	7	125	119	244
D71T40	T40	8	150	129	279
D71T45	T45	8	200	129	329
D71T50	T50	10	200	129	329

D71T107S		7PCS ANTI-SLIP GRIP STAR SCREWDRIVER SET					
----------	--	--	--	--	--	--	--

CONTENTS:							
D71T	7PCS-STAR SCREWDRIVERS : T10, T15, T20, T25, T27, T30, T40						
PACKING	COLOR BOX						

D71T109S		9PCS ANTI-SLIP GRIP STAR SCREWDRIVER SET					
----------	--	--	--	--	--	--	--

CONTENTS:							
D71T	9PCS-STAR SCREWDRIVERS : T8, T9, T10, T15, T20, T25, T27, T30, T40						
PACKING	COLOR BOX						

D71HB		ANTI-SLIP GRIP BALL POINT SCREWDRIVERS					
<ul style="list-style-type: none"> • STRONG MAGNETIC TIP • CHROME SILICIUM VANADIUM STEEL 							

ITEM NO.	SIZE	SHANK DIA. (mm)	L1 (mm)	L2 (mm)	L (mm)
D71HB2	2	2	75	72	147
D71HB25	2.5	2.5	100	72	172
D71HB3	3	3	100	72	172
D71HB4	4	4	100	90	190
D71HB5	5	5	100	110	210
D71HB6	6	6	125	119	244
D71HB8	8	8	150	129	279

D71N		ANTI-SLIP GRIP NUT DRIVERS					
• CHROME VANADIUM STEEL							

ITEM NO.	SIZE	SHANK DIA. (mm)	L1 (mm)	L2 (mm)	L (mm)
D715N05	5	1/4"	125	119	244
D715N06	6	1/4"	125	119	244
D715N07	7	1/4"	125	119	244
D715N08	8	1/4"	125	119	244
D715N09	9	1/4"	125	119	244
D715N10	10	1/4"	125	119	244
D715N11	11	1/4"	125	119	244
D715N12	12	1/4"	125	119	244
D715N13	13	1/4"	125	119	244
D715N14	14	1/4"	125	119	244

SCREWDRIVER SERIES

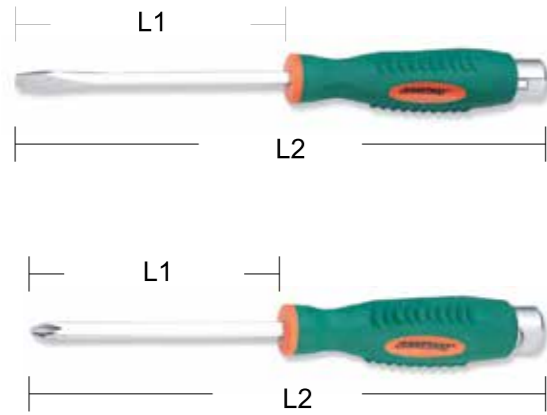

D70		GO - THRU IMPACT SCREWDRIVER						
ITEM NO.	SIZE	L1 (mm)	L2 (mm)	CUFT	WEIGHT (g)	PACKING		
						INNER PC/BOX	OUTER PC/CTN	
D70P175	PH1X75	75	182	0.8'	95	12	144	
D70P2100	PH2X100	100	227	1.0'	152	12	144	
D70P238	PH2X38	38	57	0.7'	40	12	144	
D70P3125	PH3X125	125	265	0.8'	268	12	72	
D70S475	SL4X75	75	182	0.75'	80	12	144	
D70S5100	SL5.5X100	100	207	0.85'	99	12	144	
D70S6125	SL6.5X125	125	252	1.1'	159	12	144	
D70S6150	SL6.5X150	150	277	1.15'	165	12	144	
D70S638	SL6.5X38	38	57	0.7'	40	12	144	
D70S8150	SL8X150	150	294	0.8'	250	12	72	
D70S8200	SL8X200	200	344	0.9'	269	12	72	
D70S9175	SL9.5X175	175	319	0.85'	293	12	72	
D70S9200	SL9.5X200	200	344	0.9'	301	12	72	
D70S9250	SL9.5X250	250	394	1.0'	317	12	72	

- Mechanic Go Thru Screwdriver Has Been Ergonomically Designed. The Handle has Been Created Using Impact - Resistant And Cold-Resistant Steel Made From CrMoVa, Precision And Rid Of Hydrogen Process.
- The Appliance For Any Metal Or Non-metal Operation System, Such As : Steel, Wood, Porcelain, Mineral.....ETC.
- Can be used as Punch, Chisel, Screwdriver, and Pry Bar.
- Can be used with Wrench to Increase the Torque.
- It can take 3000G Impact Of Hammer.
- D70 Mechanic Go Thru Screwdrivers Suitable For Automotive Tool, Machinery Tool, Wall Construction, And Household Use.

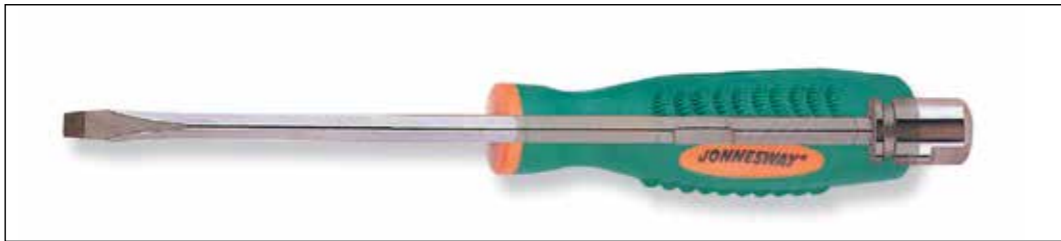

D70PP10S 10PCS GO-THRU IMPACT SCREWDRIVER SET

CONTENTS:

1-450 mm Pick Up
D70P 1.0x75, 2.0x100, 3.0x125, 2.0x38
D70S 5.5x100, 6.5x125, 8.0x150, 9.5x175, 6.5x38
6SET/CTN/14KGS/15KGS/CUFT:1.5'

D70PP07S 7PCS GO-THRU IMPACT SCREWDRIVER SET

CONTENTS:

1-450 mm Pick Up
D70P 1.0x75, 2.0x100, 3.0x125
D70S 5.5x100, 6.5x125, 8.0x150
12SET/CTN/19.5KGS/20.5KGS/1.85'

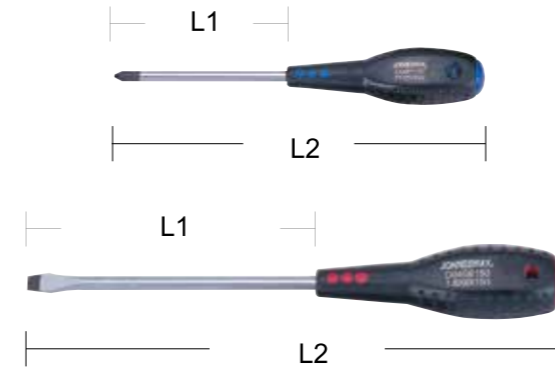

- ISO 9001 AND DIN 5262 OR 5265
- BLADES WITH HEAT TREATMENT, SATIN FINISHED, AND MAGNETIC TIPS
- ABS COMFORT GRIP, WITH PRESSURE, OIL AND ACID RESISTANCE

JONNESWAY

D04		FULL STAR SCREWDRIVER				
		• BLADES HARDENED SATIN FINISHED WITH MAGNETIC BLACK TIP • DIN 5262 OR DIN5265 • STRONG MAGNETIC				
ITEM NO.	BLADE THICKNESS x WIDTH x LENGTH	L1 (mm)	L2 (mm)	WEIGHT (g)	PACKING	
					INNER PC/BOX	OUTER PC/CTN
D04P180	PH1 x 80 (3-1/8")	80	174	55	12	144
D04P238	PH2 x 38 (1-1/2")	38	89	45	12	144
D04P2100	PH2 x 100 (4")	100	212	95	12	144
D04P3125	PH3 x 125 (5")	125	254	170	12	72
D04P3150	PH3 x 150 (6")	150	273	195	12	72
D04S480	4 x80 (5/32" x 3-1/8")	80	170	45	12	144
D04S638	6.5 x 38 (1/4" x 1-1/2")	38	109	50	12	144
D04S6100	6.5 x 100 (1/4" x 4")	100	212	95	12	144
D04S6150	6.5 x 150 (1/4" x 6")	150	260	105	12	144
D04S8150	8 x 150 (5/16" x 6")	150	280	160	12	72
D04S5125	5.5 x 125 (7/32"x 5")	125	220	60	12	144

D04PP08S 8PCS FULL STAR SCREWDRIVER SET

CONTENTS:

D04S	4PCS-SLOTTED SCREWDRIVERS : 6.5x38, 4x80, 5.5x125, 6.5x150MM
D04P	4PCS-PHILLIPS SCREWDRIVERS : PH2x38, PH1x80, PH2x100, PH3x150
PACKING	BLOWING CASE + COLOR BOX 12SETS/CTN/10KGS/11KGS/1.9'

D04PP16S 16PCS FULL STAR SCREWDRIVER SET

CONTENTS:

D04S	8PCS-SLOTTED SCREWDRIVERS : 3x50(1/8"x2"), 5.5x75(7/32" x3"), 3x150(1/8"x6"), 6.5x38(1/4"x1-1/2"), 5.5x200(7/32"x8"), 8x150(5/16"x6"), 5.5x125(7/32"x5"), 6.5x100(1/4"x4")
D04P	8PCS-PHILLIPS SCREWDRIVERS : PH1x38(1-1/2"), PH0x60(2-3/8"), PH1x150(6"), PH2x38(1-1/2"), PH2x150(6"), PH3x150(6"), PH1x80(3-1/8"),
PACKING	BLOWING CASE + COLOR BOX 6SETS/CTN/10KGS/10.2KGS/2.4'





D3750T08S 8PCS PRECISION SCREWDRIVER SET(L:50MM)

50 Length	PACKING	
	INNER PC/BOX	OUTER PC/CTN
D3750T20 ★ T20 X 50	12	72
D3750T15 ★ T15 X 50	12	72
D3750T10 ★ T10 X 50	12	72
D3750T9 ★ T9 X 50	12	72
D3750T8 ★ T8 X 50	12	72
D3750T7 ★ T7 X 50	12	72
D3750T6 ★ T6 X 50	12	72
D3750T5 ★ T5 X 50	12	72

Computer & Tooling Repair

JONNESWAY



D3750P06S 6PCS PRECISION SCREWDRIVER SET(L:50MM)

50 Length	PACKING	
	INNER PC/BOX	OUTER PC/CTN
D3750P1 ⊕ N0.1 X 50	12	72
D3750P0 ⊕ N0.0 X 50	12	72
D3750P00 ⊕ N0.00 X 50	12	72
D3750S30 ⊖ 3.0 X 50	12	72
D3750S24 ⊖ 2.4 X 50	12	72
D3750S20 ⊖ 2.0 X 50	12	72

Computer, Electric Device & Glasses Repair

JONNESWAY



D3765T06S 6PCS PRECISION SCREWDRIVER SET(L:65MM)

65 Length	PACKING	
	INNER PC/BOX	OUTER PC/CTN
D3765T10 ★ T10 X 65	12	72
D3765T9 ★ T9 X 65	12	72
D3765T8 ★ T8 X 65	12	72
D3765T7 ★ T7 X 65	12	72
D3765T6 ★ T6 X 65	12	72
D3765T5 ★ T5 X 65	12	72

Computer & Tooling Repair

JONNESWAY



D3765P08S 8PCS PRECISION SCREWDRIVER SET(L:65MM)

75 Length	PACKING	
	INNER PC/BOX	OUTER PC/CTN
D3765P1 ⊕ N0.1 X 65	12	72
D3765P0 ⊕ N0.0 X 65	12	72
D3765P00 ⊕ N0.00 X 65	12	72
D3765S30 ⊖ 3.0 X 65	12	72
D3765S24 ⊖ 2.4 X 65	12	72
D3765S20 ⊖ 2.0 X 65	12	72
D3765S35 ⊖ 3.5 X 65	12	72
D3765S40 ⊖ 4.0 X 65	12	72

Computer, Electric Device & Glasses Repair



DR0119S 19PCS RATCHET DRIVER BIT SET

- CONTENTS:**
- 1PC-RATCHET DRIVER
 - 2PCS-PHILLIPS:#1, #2(25MML)
 - 2PCS-SLOTTED:4.5, 7MM(25MML)
 - 2PCS-POZI:#1, #2(25MML)
 - 6PCS-STAR:T10, T15, T20, T25, T30, T40(25MML)
 - 6PCS-HEX:2MM, 2.5MM, 3MM, 4MM, 5MM, 6MM(25MML)

JONNESWAY



DR0253S 53PCS FLEXIBLE RATCHET DRIVER BIT SET

- CONTENTS:**
- 1PC-FLEXIBLE RATCHET DRIVER
 - 3PCS-PHILLIPS: #1, #2, #3(25MML)
 - 4PCS-SLOTTED: 3, 4, 5.5, 7MM(25MML)
 - 4PCS-POZI: #0, #1, #2, #3(25MML)
 - 6PCS-HEX: 2MM, 2.5MM, 3MM, 4MM, 5MM, 6MM(25MML)
 - 10PCS-STAR: T6, T8, T9, T10, T15, T20, T25, T27, T30, T40(25MML)
 - 8PCS-STAR W/TAMPERPROOF: T8, T10, T15, T20, T25, T27, T30, T40(25MML)
 - 1PC 1/4" HEX DRIVE SHANNKS ADAPTER
 - 15PCS-1/4"DR.6PT SOCKET: 4MM, 5MM, 6MM, 7MM, 8MM, 9MM, 10MM, 11MM, 12MM, 13MM, 3/16", 1/4", 5/16", 3/8", 1/2"
 - 1PC-MAGNETIC HOLDER

JONNESWAY



- (1) Meets DIN standard.
- (2) Integrative shaping by CNC machine improves precision.
- (3) Streamline shaping prevents stress concentration, greatly increases product endurance.
- (4) Precision tailoring provides precise cut to fit different drive codes of each screw and provides extra protection for the screw.
- (5) Special heat treatment increases the strength and tenacity, thus increases the abrasion resistance and durability
- (6) Special surface treatment to prevent precision variation caused from thickness change from plating, and greatly solve the surface rusting problem.
- (7) Special double groove tailoring provides better anti-slip grip.



RD01032S 32PCS 1/4" HEX MINI RATCHET BIT SET

- CONTENTS:**
- | |
|--|
| 1pc-Mini disc ratchet handle(1/4" bit holder)-60 teeth |
| 1pc- Magnetic bit holder-60mm |
| 30pcs 1/4" Hex shank insert bits : |
| 4pcs-Phillips: #1x1pc,#2x2pcs, #3x1pc |
| 4pcs-Hex: 3, 4, 5, 6mm |
| 2pcs-Square: SQ1,SQ2 |
| 3pcs-Pozi: PZ1,PZ2,PZ3 |
| 7pcs-Star: T10,T15,T20,T25,T27,T30,T40 |
| 3pcs-Slotted: 4, 5.5, 6.5mm |
| 7pcs-Star tamperproof: T10,T15,T20,T25,T27,T30,T40 |

JONNESWAY



RD02040S 40PCS 1/4"DR MINI RATCHET BIT SET

- CONTENTS:**
- | |
|---|
| 1pc-Mini flexible ratchet handle-60 teeth |
| 7pcs-1/4" Dr sockets:6,7,8,10,11,12,13mm |
| 1pc-1/4" Hex bit holder |
| 1pc-1/4"Dr extension bars |
| 30pcs 1/4" Hex shank insert bits : |
| 4pcs-Phillips:#1x1pc,#2x2pc, #3x1pc |
| 4pcs-Hex: 3, 4, 5, 6mm |
| 2pcs-Square:SQ1,SQ2 |
| 3pcs-POZI:PZ1,PZ2,PZ3 |
| 7pcs-Star:T10,T15,T20,T25,T27,T30,T40 |
| 3pcs-Slotted:4, 5.5, 6.5mm |
| 7pcs-Star tamperproof:T10,T15,T20,T25,T27,T30,T40 |



S08H208S	8PCS 1/4" DR. BIT SET
CONTENTS:	
	7PCS-1/4" BIT (30MML) : PHILLIPS BITS : PH1, PH2, PH3 SLOTTED BITS : 4, 7MM POZI BITS : PZ1, PZ2
	1PC-OFFSET BIT HOLDER WRENCH
PACKING	BLISTER CARD 100SET/CTN/12.3KGS/13.5KGS/CUFT : 1.1'

JONNESWAY



S08H2H8S	8PCS 1/4" DR. HEX BIT SET
CONTENTS:	
	7PCS-HEX BITS : 2, 3, 4, 5, 6, 7, 8MM (30MML)
	1PC-OFFSET BIT HOLDER WRENCH
PACKING	BLISTER CARD 100SET/CTN/12.3KGS/13.5KGS/1.1'

JONNESWAY



S29H2133S	33PCS 1/4" DR. SECURITY BIT SET
CONTENTS:	
	1PC-MAGNETIC BIT HOLDER (60MML)
	32PCS-1/4" SECURITY BIT (25MML)
	STAR SET 6, 8, 10 TRI-WING 1, 2, 3, 4
	SPANNER 4, 6, 8, 10 HEX SECURITY 5/32", 9/64", 1/8", 7/64", 3/32", 5/64", 2, 2.5, 3, 4, 5, 6MM
	9PCS-STAR TAMPERPROOF T-8H, T-10H, T-15H, T-20H, T-25H, T-27H, T-30H, T-35H, T-40H
PACKING	PLASTIC CASE + SLIDE CARD 48SETSCTN/12KGS/13KGS/0.78'

JONNESWAY



S29H4140S	40PCS 3/8" & 1/2" DR. POWER BIT SET
CONTENTS:	
	14-10MM HEX BITS : 30MML : 4, 5, 6, 7, 8, 10, 12 75MML : 4, 5, 6, 7, 8, 10, 12
	14-10MM STAR BITS : 30MML : T20, T25, T30, T40, T45, T50, T55 75MML : T20, T25, T30, T40, T45, T50, T55
	10-10MM SPLINE BITS : 30MML : M5, M6, M8, M10, M12 75MML : M5, M6, M8, M10, M12
	2PCS-BIT HOLDERS : 3/8" DR. x 10MM, 1/2" DR. x 10MM
PACKING	10SET/CTN/21KGS/23KGS/0.75'



Turn 30° easy remove



HEX KEY

- Anti-slippery grooves
- More torque increased

H02SA109S	9PCS ANTI-SLIP LONG ARM HEX KEY SET (MM)
	• S2 • CHROME PLATED

CONTENTS:	
H02SA109S	9PCS: 1.5, 2, 2.5, 3, 4, 5, 6, 8, 10MM

- Anti - Slippery Grooves
- More Torque Increased

JONNESWAY



Turn 30° easy remove



HEX KEY

- Anti-slippery grooves
- More torque increased

H03SA109S	9PCS ANTI-SLIP EXTRA LONG ARM HEX KEY SET (MM)
------------------	---

H03SA209S	9PCS ANTI-SLIP EXTRA LONG ARM HEX KEY SET (SAE)
------------------	--

CONTENTS:	
H03SA109S	9PCS - 1.5, 2, 2.5, 3, 4, 5, 6, 8, 10 MM
H03SA209S	9PCS - 1/16", 5/64", 3/32", 1/8", 5/32", 3/16", 1/4", 5/16", 3/8"

- Anti - Slippery Grooves
- More Torque Increased

JONNESWAY



Turn 30° easy remove



BALL POINT

- New strap line design
- Much more space touched
- More torque increased



HEX KEY

- Anti-slippery grooves
- More torque increased

H06SA109S	9PCS ANTI-SLIP EXTRA LONG ARM BALL POINT HEX KEY SET (MM)
------------------	--

H06SA209S	9PCS ANTI-SLIP EXTRA LONG ARM BALL POINT HEX KEY SET (SAE)
------------------	---

CONTENTS:	
H06SA109S	9PCS - 1.5, 2, 2.5, 3, 4, 5, 6, 8, 10 MM
H06SA209S	9PCS - 1/16", 5/64, 3/32, 1/8", 5/32", 3/16, 1/4", 5/16", 3/8"

- Anti - Slippery Grooves
- More Torque Increased

JONNESWAY



H16	9PC EXTRA LONG ARM STAR HEX KEY SET
------------	--

CONTENTS:	
H16109S	9PCS - TS10, TS15, TS20, TS25, TS27, TS30, TS40, TS45, TS50



H01M07SF	7PCS FOLDABLE HEX KEY SET(MM)
	• CR-V • CHROME PLATED
H01M08SF	8PCS FOLDABLE HEX KEY SET(SAE)
	• CR-V • CHROME PLATED

CONTENTS:

H01M07SF	7PCS : 2.5, 3, 4, 5, 6, 8, 10MM
H01M08SF	8PCS : 5/64", 3/32", 1/8", 5/32", 3/16", 1/4", 5/16", 3/8"

JONNESWAY

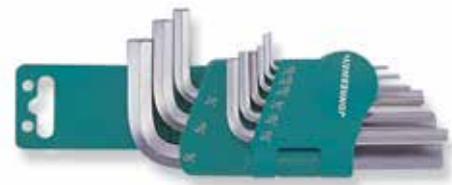

H01SM109S	9PCS SHORT ARM HEX KEY SET(MM)
	• S2 • CHROME PLATED
H01SM209S	9PCS SHORT ARM HEX KEY SET(SAE)
	• S2 • CHROME PLATED

CONTENTS:

H01SM109S	9PCS : 1.5, 2, 2.5, 3, 4, 5, 6, 8, 10MM
H01SM209S	9PCS : 1/16", 5/64", 3/32", 1/8", 5/32", 3/16", 1/4", 5/16", 3/8"

JONNESWAY



H02SM109S	9PCS LONG ARM HEX KEY SET(MM)
	• S2 • CHROME PLATED
H02SM209S	9PCS LONG ARM HEX KEY SET(SAE)
	• S2 • CHROME PLATED

CONTENTS:

H02SM109S	9PCS : 1.5, 2, 2.5, 3, 4, 5, 6, 8, 10MM
H02SM209S	9PCS : 1/16", 5/64", 3/32", 1/8", 5/32", 3/16", 1/4", 5/16", 3/8"

JONNESWAY



H05SM109S	9PCS LONG ARM BALL POINT HEX KEY SET(MM)
	• S2 • CHROME PLATED
H05SM209S	9PCS LONG ARM BALL POINT HEX KEY SET(SAE)
	• S2 • CHROME PLATED

CONTENTS:

H05SM109S	9PCS : 1.5, 2, 2.5, 3, 4, 5, 6, 8, 10MM
H05SM209S	9PCS : 1/16", 5/64", 3/32", 1/8", 5/32", 3/16", 1/4", 5/16", 3/8"

JONNESWAY



H06S109S	9PCS EXTRA LONG ARM BALL POINT HEX KEY SET(MM)
	• S2 • SATIN FINISHED
H06S209S	9PCS EXTRA LONG ARM BALL POINT HEX KEY SET(SAE)
	• S2 • SATIN FINISHED

CONTENTS:

H06S109S	9PCS : 1.5, 2, 2.5, 3, 4, 5, 6, 8, 10MM
H06S209S	9PCS : 1/16", 5/64", 3/32", 1/8", 5/32", 3/16", 1/4", 5/16", 3/8"
PACKING	HOLDER + SLIDE CARD 36SETS/CTN/17.5KGS/18.5KGS/1.6'

120



H05SM1	LONG ARM BALL POINT HEX KEY (SAE)
	• S2 • CHROME PLATED

ITEM NO.	SIZE (MM)
H05SM115	1.5
H05SM120	2.0
H05SM125	3.0
H05SM130	3.0
H05SM140	4.0
H05SM150	5.0
H05SM160	6.0
H05SM180	8.0
H05SM1100	10.0

JONNESWAY



H05SM2	LONG ARM BALL POINT HEX KEY (SAE)
	• S2 • CHROME PLATED

ITEM NO.	SIZE (INCH)
H05SM215	1116"
H05SM220	5/64"
H05SM225	3/32"
H05SM230	1/8"
H05SM240	5/32"
H05SM250	3/16"
H05SM260	1/4"
H05SM280	5/16"
H05SM2100	3/8"

JONNESWAY



H06S1	EXTRA LONG ARM BALL POINT HEX KEY (MM)
	• S2 • SATIN FINISHED

ITEM NO.	SIZE (MM)
H06S115	1.5
H06S120	2
H06S125	3.
H06S130	3
H06S140	4
H06S150	5
H06S160	6
H06S180	8
H06S1100	10

JONNESWAY



H06S2	EXTRA LONG ARM BALL POINT HEX KEY (SAE)
	• S2 • SATIN FINISHED

ITEM NO.	SIZE (INCH)
H06S215	1/16"
H06S220	5/64"
H06S225	3/32"
H06S230	1/8"
H06S240	5/32"
H06S250	3/16"
H06S260	1/4"
H06S280	5/16"
H06S2100	3/8"

121



H03MT109S	9 IN 1 9PCS EXTRA LONG ARM HEX KEY SET W/HANDLE • SNCM+V #8660 • MAT FINISHED
------------------	--

CONTENTS:	
H03MT109S	9PCS : 1.5, 2, 2.5, 3, 4, 5, 6, 8, 10MM

JONNESWAY



H06MT109S	9 IN 1 9PCS EXTRA LONG ARM BALL POINT HEX KEY SET W/HANDLE • SNCM+V #8660 • MAT FINISHED
------------------	---

CONTENTS:	
H06MT109S	9PCS - 1.5,2,2.5,3,4,5,6,8,10 MM

JONNESWAY



H08MT109S	9 IN 1 9PCS EXTRA LONG ARM STAR TAMPERPROOF KEY SET • SNCM+V #8660 • CHROME PLATED
------------------	---

CONTENTS:	
H08MT109S	9PCS : T10, T15, T20, T25, T27, T30, T40, T45, T50

JONNESWAY



H07M08SF	8PCS STAR KEY FOLDING SET • CR-V • CHROME PLATED
-----------------	---

CONTENTS:	
8PCS : T9, T10, T15, T20, T25, T27, T30, T40	
PACKING	FOLDING + SLIDE CARD 72SETS/CTN/15.8KGS/16.8KGS/0.86'

JONNESWAY



H08M07S	7PCS STAR KEY SET • S2 • CHROME PLATED
----------------	---

CONTENTS:	
7PCS : T10, T15, T20, T25, T27, T30, T40	
PACKING	HOLDER + SLIDE CARD 144SETS/CTN/18.7KGS/19.7KGS/1.43'

JONNESWAY



H07M09S	9PCS STAR KEY SET • S2 • CHROME PLATED
H08MTP09S	9PCS STAR KEY W/TAMPERPROOF SET • S2 • CHROME PLATED

CONTENTS:	
9PCS-T10, T15, T20, T25, T27, T30, T40, T50	
PACKING	PLASTIC CASE 72SETS/21KGS/22KGS/0.9'

JONNESWAY



H08S110S	10PCS EXTRA LONG ARM STAR TAMPERPROOF KEY SET • S2 • SATIN FINISHED
-----------------	--

CONTENTS:	
H08S	10PCS : T9, T10, T15, T20, T25, T27, T30, T40, T45, T50



H10MB08S	8PCS TWO WAY BALL POINT & HEX KEY SET • 8660 • MAT FINISHED
-----------------	--

CONTENTS:	
H10MB	8PCS : 2X100, 2.5X100, 3X100, 4X100, 5X150, 6X150, 8X200, 10X200MM

JONNESWAY



H10MT09S	9PCS TWO WAY STAR & TAMPERPROOF KEY SET • 8660 • MAT FINISHED
-----------------	--

CONTENTS:	
H10MT	9PCS : T10X100, T15X100, T20X100, T25X100, T27X150, T30X150, T40X150, T45X200, T50X200MM

JONNESWAY



H10MT	TWO WAY STAR & TAMPERPROOF KEY
--------------	---

ITEM NO.	SIZE	L1 (mm)
H10MT10100	T10	100
H10MT15100	T15	100
H10MT20100	T20	100
H10MT25100	T25	100
H10MT27150	T27	150
H10MT30150	T30	150
H10MT40150	T40	150
H10MT45200	T45	200
H10MT50200	T50	200

JONNESWAY



H10MB	TWO WAY BALL POINT & HEX KEY
--------------	---

ITEM NO.	SIZE	L1 (mm)
H10MB2100	2	100
H10MB25100	2.5	100
H10MB3100	3	100
H10MB4100	4	100
H10MB5150	5	150
H10MB6150	6	150
H10MB8200	8	200
H10MB10200	10	200

JONNESWAY

HEX KEY

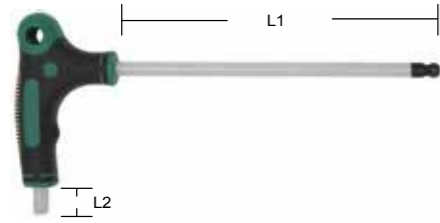

H20MB		TWO WAY BALL POINT HEX KEY (SAE)	
S2			
ITEM NO.	SIZE	L1 (mm)	L2 (mm)
H20MB2020	H5/64	100	12
H20MB2025	H3/32	110	12
H20MB2030	H1/8	120	12
H20MB2040	H5/32	125	14
H20MB2050	H3/16	155	15
H20MB2060	H1/4	165	15
H20MB2080	H5/16	185	16
H20MB20100	H3/8	210	20

JONNESWAY



H02MH		LONG ARM HEX KEY SET	
• Material : Chrome Vanadium steel, Chrome Plated.			
ITEM NO.	PCS	SIZE	
H02MH118S	18	1.5, 2, 2.5, 3, 3.5, 4, 4.5, 5, 5.5, 6, 7, 8, 9, 10, 12, 14, 17, 19MM	

JONNESWAY



MK2040		QUICK CHANGE BLADE RETRACTABLE UTILITY KNIFE W/2PCS BLADE	
Special Features :			
		<ul style="list-style-type: none"> • Oil Resistance • Rubber Paint for Non-Slip function • Cold Resistance to -20° • Quick Change Blade Function. 	
PACKING	BLISTER CARD	72SETS/CTN/19.5KGS/20.5KGS/2.3'	



M04		BALL PEEN HAMMER			
• 60% FIBERGLASS HANDLE W/PP JACKETED & OVERMOULDED TPR GRIP					
ITEM NO.	HEAD WGT (OZ)	LENGTH (mm)	WEIGHT (g)	PACKING	
				INNER PC/BOX	OUTER PC/CTN
M04008	8	278±6	395	12	48
M04012	12	283±6	527	6	36
M04016	16	327±6	780	6	36
M04024	24	383±6	1063	6	24
M04032	32	385±6	1208	4	24

JONNESWAY



M08		BALL PEEN HAMMER			
• WITH HICKORY HANDLE					
ITEM NO.	HEAD WGT (OZ)	LENGTH (mm)	WEIGHT (g)	PACKING	
				INNER PC/BOX	OUTER PC/CTN
M08012	12	325±6	444	6	36
M08016	16	350±6	584	6	36
M08024	24	396±6	1042	6	24
M08032	32	400±6	1208	4	24

JONNESWAY



M05		CLAW HAMMER			
• 60% FIBERGLASS HANDLE W/PP JACKETED & OVERMOULDED TPR GRIP					
ITEM NO.	HEAD WGT (OZ)	LENGTH (mm)	WEIGHT (g)	PACKING	
				INNER PC/BOX	OUTER PC/CTN
M05016	16	330±6	750	6	36
M05020	20	330±6	830	6	24

JONNESWAY



M07		SOFT FACE HAMMER			
• TPR MATERIAL (BLACK) • TRANSPARENT ACETATE MATERIAL					
ITEM NO.	HEAD WGT (OZ)	LENGTH (mm)	WEIGHT (g)	PACKING	
				INNER PC/BOX	OUTER PC/CTN
M07016	16	314	840	6	24

HAMMER



M03	SOLID STEEL ONE PIECE CLUB HAMMER
	• WITH SHOCKWAVE TPR GRIP

ITEM NO.	HEAD WGT (lb)	LENGTH (mm)	WEIGHT (g)	PACKING	
				INNER PC/BOX	OUTER PC/CTN
M03040	4	276±6	2167	4	12

JONNESWAY



M06	CLUB HAMMER
	• 60% FIBERGLASS HANDLE W/PP JACKETED & OVERMOULDED TPR GRIP

ITEM NO.	HEAD WGT (lb)	LENGTH (mm)	WEIGHT (g)	PACKING	
				INNER PC/BOX	OUTER PC/CTN
M06030	3	263±6	1550	4	12
M06040	4	276±6	2250	4	12

JONNESWAY



M09	ENGINEER'S HAMMER
	• WITH HICKORY HANDLE

ITEM NO.	HEAD WEIGHT (g)	LENGTH (mm)	PACKING	
			INNER PC/BOX	OUTER PC/CTN
M09300	300	300±6	6	48
M09500	500	320±6	6	36

JONNESWAY



M11	DEAD BLOW HAMMER
	• STEEL HAMMER GRIP COVERED WITH SYNTHETIC RUBBER

ITEM NO.	HEAD DIA (mm)	OVERALL LENGTH (mm)	WEIGHT (g)	PACKING	
				INNER PC/BOX	OUTER PC/CTN
M11035	35	260	400	6	48
M11045	45	286	520	6	36
M11055	55	350	1050	4	24
M11065	65	370	1500	4	16



JONNESWAY

M60	CENTER PUNCH
	• CHROME VANADIUM • PHOSPHATE SUNK FINISHED

ITEM NO.	SIZE	L (mm)	HEX SHANK (mm)	WEIGHT (g)	PACKING	
					INNER PC/BOX	OUTER PC/CTN
M60102	2	120	9.5	33	200	400
M60103	3	100	8	33	200	400
M60104	4	120	9.5	57	200	400
M60105	5	150	12.7	114	90	180



JONNESWAY

M61	COLD CHISEL
	• CHROME VANADIUM • PHOSPHATE SUNK FINISHED

ITEM NO.	SIZE	L (mm)	HEX SHANK (mm)	WEIGHT (g)	PACKING	
					INNER PC/BOX	OUTER PC/CTN
M61110	10	150	9.5	80	120	240
M61112	12	130	9.5	80	120	240
M61113	13	150	9.5	82	120	240
M61116	16	180	12.7	171	60	120
M61119	19	180	15.8	260	40	80
M61122	22	200	15.8	307	30	60
M61125	25	200	19.0	449	25	50



JONNESWAY

M62	TAPER PUNCH
	• CHROME VANADIUM • PHOSPHATE SUNK FINISHED

ITEM NO.	SIZE	L (mm)	HEX SHANK (mm)	WEIGHT (g)	PACKING	
					INNER PC/BOX	OUTER PC/CTN
M62102	2	120	9.5	53	200	400
M62103	3	120	9.5	55	200	400
M62104	4	120	9.5	57	200	400
M62105	5	120	9.5	59	200	400
M62106	6	120	9.5	60	200	400



JONNESWAY

M63	PIN PUNCH
	• CHROME VANADIUM • PHOSPHATE SUNK FINISHED

ITEM NO.	SIZE	L (mm)	HEX SHANK (mm)	WEIGHT (g)	PACKING	
					INNER PC/BOX	OUTER PC/CTN
M63102	2X30	115	8	33	250	500
M63103	3X40	125	8	34	250	500
M63104	4X50	150	9.5	63	150	300
M63105	5X50	165	9.5	71	150	300
M63106	6X53	180	12.7	132	80	160
M63108	8X53	180	12.7	144	70	140



JONNESWAY

M64105S	5PCS CHISEL PUNCH SET
	• PHOSPHATE SUNK FINISHED

CONTENTS:	
M63104	1PC-PIN PUNCH : 4 x 9.5 x 150MM
M64105	1PC-CAPE CHISEL : 5 x 9.5 x 130MM
M61112	1PC-COLD CHISEL : 12 x 9.5 x 130MM
M62103	1PC-TAPER PUNCH : 3 x 9.5 x 120MM
M60102	1PC-CENTER PUNCH : NO.2 x 9.5 x 120MM
PACKING	PLASTIC HOLDER + SLIDER CARD 40SETS/CTN/15KGS/16KGS/0.5'



M63106S	6PCS PIN PUNCH SET
	• PHOSPHATE SUNK FINISHED

CONTENTS:	
M63	6PCS-PIN PUNCH : 2x8.0x115MM, 3x8.0x125MM, 4x9.5x150MM, 5x9.5x165MM, 6x12.7x180MM, 8x12.7x180MM
PACKING	PLASTIC HOLDER + SLIDER CARD 30SETS/CTN/16KGS/17KGS/0.6'

- Easy to read digital Large LCD display with inch / metric conversion.
- Made of hardened, stainless steel.



MTC LARGE RANGE ELECTRONIC CALIPER

ITEM NO.	SIZE	DIMENSION (mm)	PACKING	N.W/G.W/CUF
MTC150	6"	150X0.01MM	50/CTN	16.0/18.0/1.6
MTC200	8"	200X0.01MM	50/CTN	18.0/20.0/2.3
MTC300	12"	300X0.01MM	20/CTN	10.4/15.0/1.65

JONNESWAY

- Made of stainless steel.
- Four measurements - inside, outside, depth and step.



MTC1 VERNIER CALIPER

ITEM NO.	SIZE	DIMENSION (mm)	PACKING	N.W/G.W/CUF
MTC1150	6"/ 15 CM	150X0.02MM	50/CTN	16.0/17.0/1.53
MTC1200	8"/ 20 CM	200X0.02MM	50/CTN	20.4/22.0/2.24
MTC1300	12"/30 CM	300X0.02MM	20/CTN	14.6/16.3/1.60

JONNESWAY

- Made of stainless steel.
- Dialindicator has fine line indicating hand.
- Four measurements - inside, outside, depth and step.



MTC2 DIAL VERNIER CALIPER

ITEM NO.	SIZE	DIMENSION (mm)	PACKING	N.W/G.W/CUF
MTC2150	6"	150X0.02MM	50/CTN	13.0/15.0/1.0
MTC2200	8"	200X0.02MM	50/CTN	17.0/19.0/1.4
MTC2300	12"	300X0.02MM	25/CTN	16.0/18.0/1.4

JONNESWAY

- Satin chrome finished thimble and handle with easy reading scale.



MTM MICROMETERS

ITEM NO.	SIZE	PACKING	N.W/G.W/CUF
MTM1025	0-25MM	50/CTN	15.0/16.0/0.6
MTM1050	25-50MM	50/CTN	25.0/26.0/0.8
MTM1075	50-75MM	30/CTN	24.0/25.0/1.2
MTM1100	75-100MM	25/CTN	20.0/21.0/1.0

JONNESWAY

- MTC 155 Technical pencil with tungsten lead.



MTC155 UNILITY TECHNICAL PENCIL

ITEM NO.	SIZE	PACKING	N.W/G.W/CUF
MTC155	2.0MM	300/CTN	6.0/7.0/0.6

- Polish finish.
- Material : carbon steel.

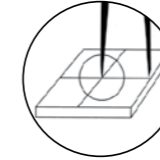

MTC3 QUICK ADJUST DIVIDERS

ITEM NO.	SIZE	PACKING	N.W/G.W/CUF
MTC306	6"	10/box, 100/CTN	12.0/13.5/2.5
MTC308	8"	10/box, 100/CTN	16.0/17.0/2.5

JONNESWAY

- Polish finish.
- Material : carbon steel.



MTC4 QUICK ADJUST OUTSIDE CALIPERS

ITEM NO.	SIZE	PACKING	N.W/G.W/CUF
MTC406	6"	10/box, 100/CTN	12.0/13.5/2.5
MTC408	8"	10/box, 100/CTN	16.0/17.0/2.5

JONNESWAY

- Polish finish.
- Material : carbon steel.

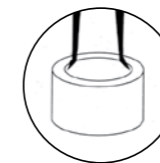

MTC5 QUICK ADJUST INSIDE CALIPERS

ITEM NO.	SIZE	PACKING	N.W/G.W/CUF
MTC506	6"	10/box, 100/CTN	12.0/13.5/2.5
MTC508	8"	10/box, 100/CTN	16.0/17.0/2.5

JONNESWAY



MT07	MEASURING TAPES 3M X 19MM		
	<ul style="list-style-type: none"> • HIGH IMPACT ABS CASE W/ RUBBER PROTECTED • RUBBER COVERED CASE, COMFORTABLE 		

ITEM NO.	SIZE	PACKING	
		INNER PC/BOX	OUTER PC/CTN
MT0701	3Mx19MM	12	120

JONNESWAY



MT03	MEASURING TAPES 7.5M / 25FT		
	<ul style="list-style-type: none"> • HIGH IMPACT ABS CASE W/ RUBBER PROTECTED • RUBBER COVERED CASE, COMFORTABLE 		

ITEM NO.	SIZE	PACKING	
		INNER PC/BOX	OUTER PC/CTN
MT0303	7.5M / 25FT x 1" (25mm)	6	48

JONNESWAY



MHS100AG	HEAVY DUTY DELUXE TYPE HACKSAW W/12" H.S.S. BLADE
-----------------	--

Special Features :

	<ul style="list-style-type: none"> • Blade being positioned for 45° or 90° normal cutting • Adjustable handle to increase tension up to 34000 PSI Torque • Extra blades to be stored in top bar
PACKING	COLOR SLEEVE 36SETS/CTN/23KGS/24KGS/2.2'



AIR TOOLS SERIES

- Industrial Safety
- Excellent Performance
- Powerful & Low Noise
- Compact & Light Weight

AIR IMPACT WRENCH SERIES



The NEW upgraded ULTRA-LIGHT IMPACT WRENCH with compact mechanism which highly reduce the tool's weight and volume more than 30%. With SIX unique functions, it is not only increase the operation efficiency but also enhance operating comfortable and convenience for the end users.

Market Sales Application:

The design for repair of heavy truck tire and large engineering construction, like railway and bridge building.....etc.

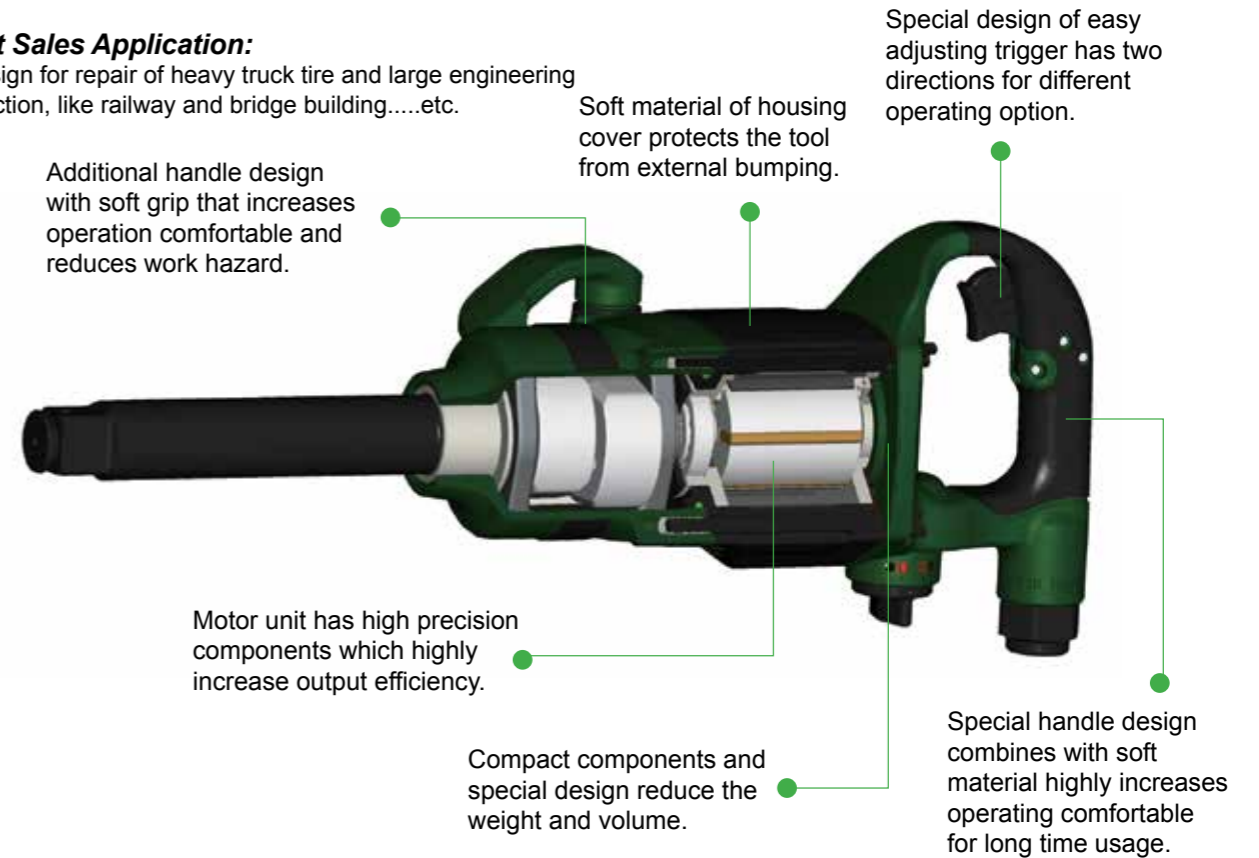

JAI-1138L 1" SQ.DR.Super Duty Air Impact Wrench W/6" Extended Anvil

TECHNICAL DATA	JAI-1138L	
Square Drive	1"	
Std Bolt Size	1-27/64"	M36
Free Speed (rpm)	5,000	
Working Torque	1,800 (ft-lb)	2,430 (Nm)
MAX. Torque	2,000 (ft-lb)	2,712 (Nm)
Overall Length	19.2"	487 (mm)
Air Inlet Size	1/2"	
Air Hose (I.D)	3/4"	
Avg. Air Consumption	9 (cfm)	255 (l/min)
Net Weight	18.3 (lbs)	8.3 (kgs)
Clutch Mechanism	Twin Hammer	
Vibration (M/S ²)	18	
Noise Level (dBA)	98	



The new advance **ULTRA-LIGHT IMPACT WRENCH** with compact mechanism which highly reduce the tool's weight and volume more than 30%. With several special functions, they increase operating comfort and efficiency. Also they improve convenience for longtime usage.

Market Sales Application:

The friendly design for repair of heavy truck tire and large engineering construction, such as railway , bridge building and steel construction building.....etc.

AIR IMPACT WRENCH SERIES

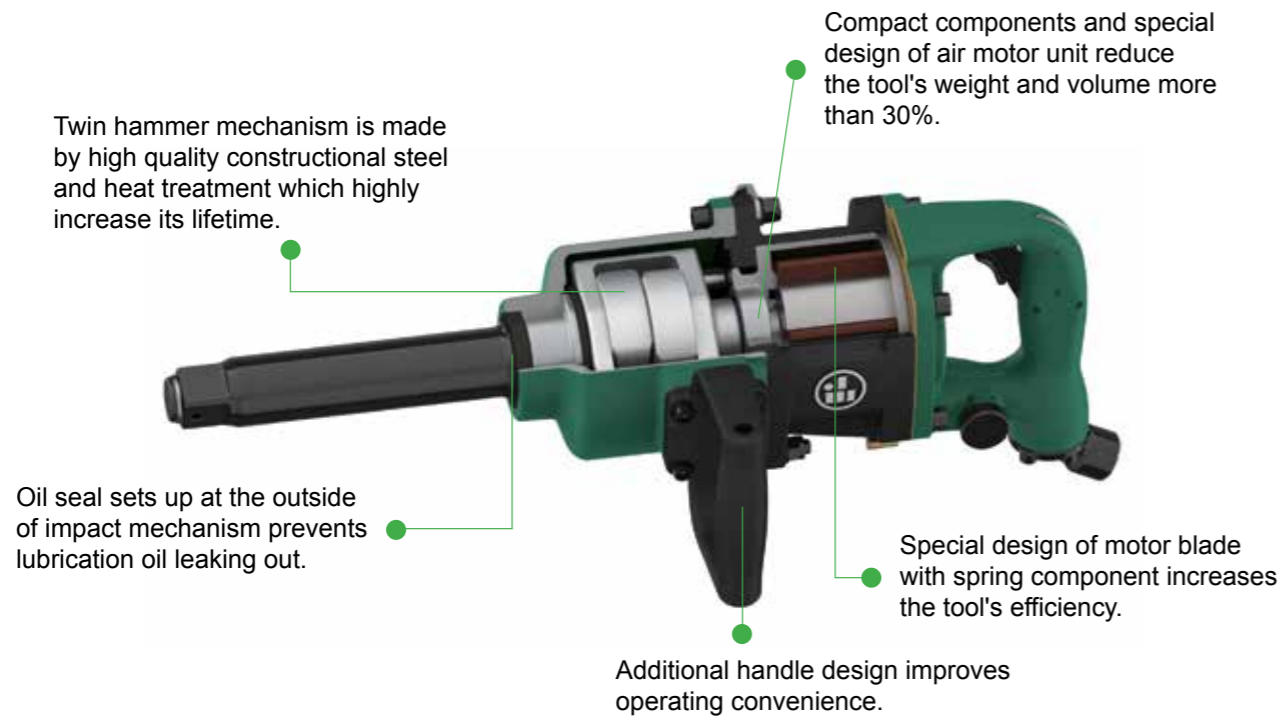

JAI-1408L 1" SQ. DR. Super Duty Air Impact Wrench W/8" Extended Anvil-----twin Hammer

TECHNICAL DATA		JAI-1408L	
Square Drive	1"		
Std. Bolt Size	1-3/4"	45mm	
Free Speed (rpm)	4,800		
Working Torque	2,400(Ft-lb)	3,270(N.M.)	
Max Torque	2,600(Ft-lb)	3,520(N.M.)	
Overall Length	22.5"	570 (mm)	
Air Inlet Size	1/2"		
Air Hose (I.D.)	1/2"		
Air Pressure	90 PSI		
Avg. Air Consumption	16 (cfm)	450 (l/min)	
Net Weight	26.2 (lbs)	11.9 (kgs)	
Clutch Mechanism	Twin Hammer		
Exhaust Direction	Side Exhaust		
Vibration	M/S ²	12.32	
	K (M/S ²)	1.72	
Sound	Pressure A (dB)	94.5	
	Power A (dB)	105.5	
	Pressure C (dB)	93.9	
	K (dB)	3	



The **NEW upgraded HEAVY-DUTY COMPOSITE IMPACT WRENCH** with special patent design twin hammer mechanism offer you seven unique functions for easy operation which 20% light weight compare with Alumium-Alloy Tools and 10% higher torque reached compare tools with same standard.

1. The anvil is made by high quality material with special heat treatment to improve its lifetime.

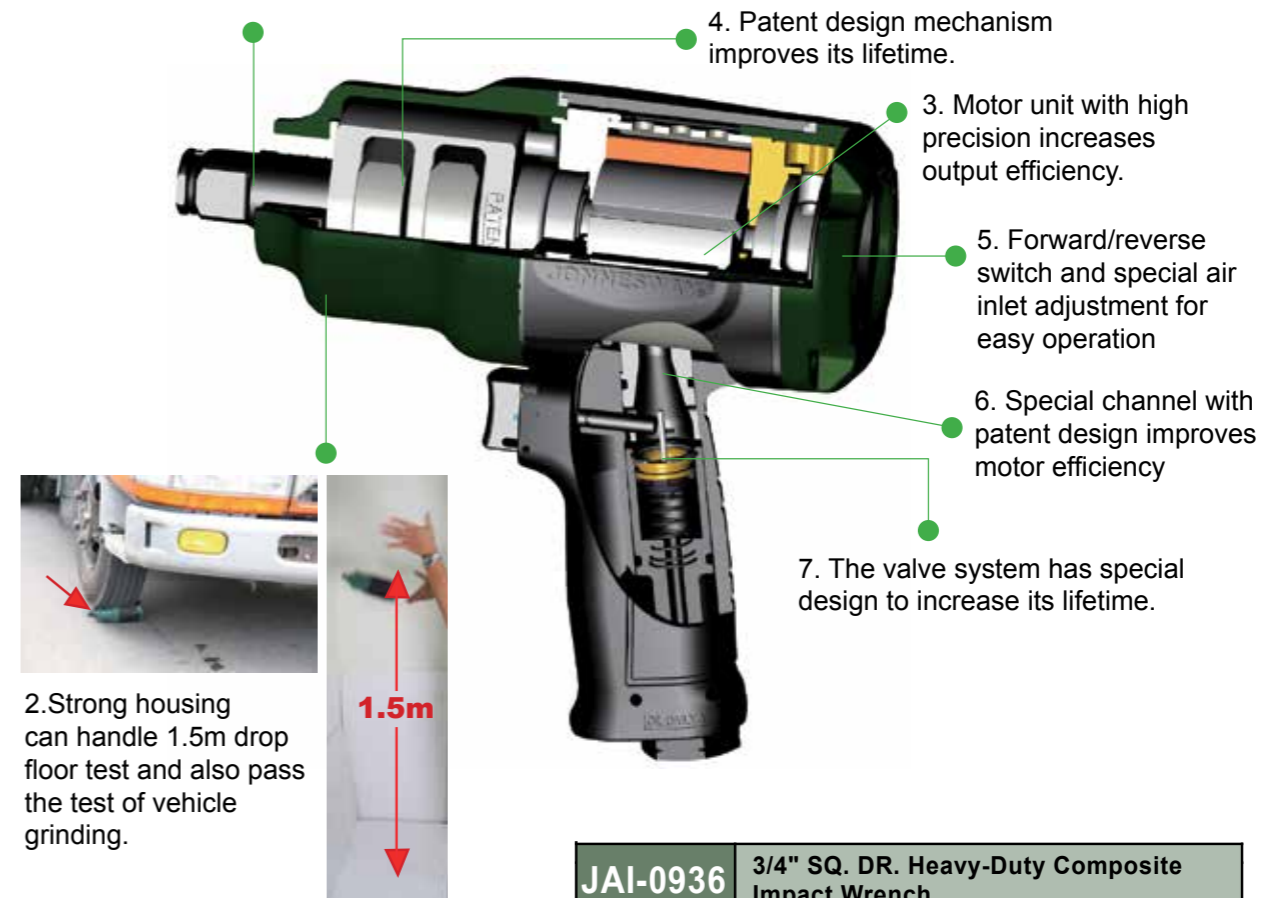

JAI-0936 3/4" SQ. DR. Heavy-Duty Composite Impact Wrench

TECHNICAL DATA		JAI-0936	
Square Drive	3/4"		
Std Bolt Size	1"	M25	
Free Speed (rpm)	6,500		
Working Torque	1,200 (Ft-lb)	1,620 (N.M.)	
MAX. Torque	1,500 (Ft-lb)	2,025 (N.M.)	
Overall Length (mm)	8-55/64"	225 (mm)	
Air Inlet Size (PT)	3/8"		
Air Hose (I.D.)	1/2"		
Avg. Air Consumption	6.7 (cfm)	190 (l/min)	
Net Weight	8.58 (lbs)	3.89 (kgs)	
Noise Level (dB)	90.5		
Vib. (M/S ²)	4		
Clutch Mechanism	Twin Hammer		
Exhaust Direction	Rear Exhaust		



AIR IMPACT WRENCH SERIES



JAI-0924 1/2" DR. Composite Impact Wrench

TECHNICAL DATA		JAI-0924	
Square Drive		1/2"	
Max Torque		550 Ft-lb	746 N.M.
Working Torque		510 Ft-lb	681 N.M.
Free Speed	rpm	8,500	
Std Bolt Size	in	5/8	
	mm	16	
Length	in	7.52	
	mm	191	
Weight	lbs	4.27	
	kgs	1.94	
Min Hose Size	in	3/8	
	mm	10	
Ave. air Consumption	cfm	4.7	
	l/mm	133	
Air Inlet Size		1/4"	
Noise Level (dBA)		98.5	
Vibration (M/S ²)		4.31	
Clutch Mechanism		Twin Hammer	

The "Stubby" Impact Wrench, includes special design of "Jumbo Hammer Mechanism" and short length idea that reduce the tool's length and weight. Its tightness design can go through narrow area and high torque output function increases its excellent performance. Also the tool has light weight and short length much less 20% than traditional product.

Market Sales Application:

Ideal for tire change, mold and machine equipment assembly, and agriculture machinery.

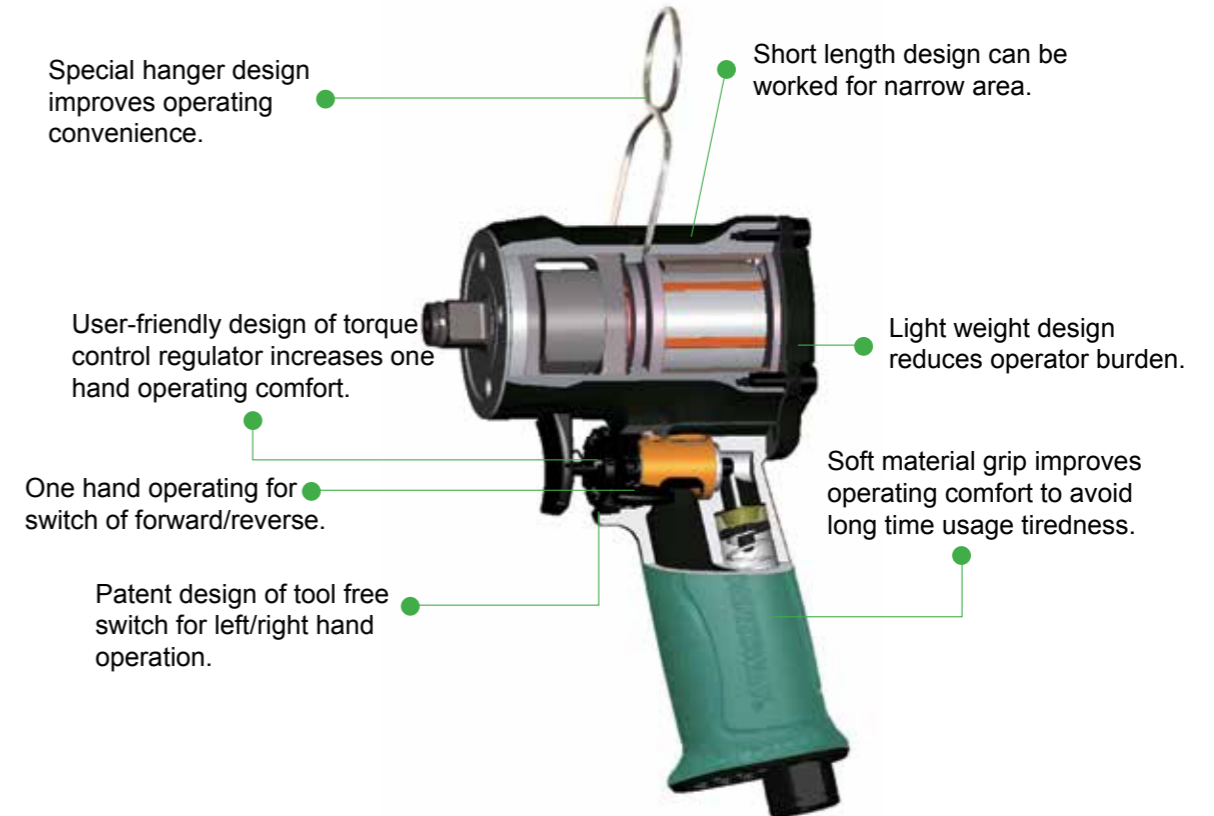

JAI-0923 3/8" DR. Composite Impact Wrench

TECHNICAL DATA		JAI-0923	
Square Drive		3/8"	
Max Torque		280 Ft-lb	380 N.M.
Working Torque		250 Ft-lb	335 N.M.
Free Speed	rpm	11,000	
Std Bolt Size	in	1/2	
	mm	13	
Length	in	6.56	
	mm	166.5	
Weight	lbs	2.6	
	kgs	1.2	
Min Hose Size	in	3/8	
	mm	10	
Ave. air Consumption	cfm	2.5	
	l/mm	71	
Air Inlet Size		1/4"	
Noise Level (dBA)		92.5	
Vibration (M/S ²)		4.3	
Clutch Mechanism		Twin Hammer	



JAI-1014 1/2" Stubby Impact Wrench

TECHNICAL DATA		JAI-1014	
Square Drive		1/2"	
Std. Bolt Size		5/8"	M16
Free Speed (rpm)		10,000	
Working Torque		420(Ft-lb)	560(N.M.)
Max Torque		450(Ft-lb)	600(N.M.)
Overall Length		4.27"	108.5 (mm)
Air Inlet Size		1/4"	
Air Hose (I.D.)		3/8"	
Air Pressure		90 PSI	
Avg. Air Consumption		4.5 (cfm)	127 (l/min)
Net Weight		2.87 (lbs)	1.3 (kgs)
Clutch Mechanism		Jumbo Hammer	
Exhaust Direction		Rear Exhaust	
Vibration	M/S ²	9.57	
	K (M/S ²)	1.44	
Sound	Pressure A (dB)	97.1	
	Power A (dB)	108.1	
	Pressure C (dB)	103	
	K (dB)	3	



JAI-6211	3/4" Super Duty Air Impact Wrench W/2" Anvil			
JAI-6211L	3/4" Super Duty Air Impact Wrench W/6" Anvil			
TECHNICAL DATA	JAI-6211		JAI-6211L	
Square Drive	3/4"		3/4"	
Std Bolt Capacity	1"	M25	1"	M25
Free Speed (RPM)	6500			
Max. Torque	750 Ft-Lbs	1016 N.M.	750 Ft-Lbs	1016 N.M.
Overall Length	9-19/64"	236 MM	15-19/64"	388 MM
Air Inlet	1/4"		1/4"	
Air Hose (I.D.)	3/8"	9.5 MM	3/8"	9.5 MM
Air Pressure	90 PSI	6.3kg/cm ²	90 PSI	6.2 BAR
Air Consumption	7 CFM	198 L/MIN	7 CFM	198 L/MIN
Anvil Length	2"		6"	
Clutch Mechanism	Twin Hammer		Twin Hammer	
Weight	10.0 LBS	4.55 KGS	10.15 LBS	4.66 KGS
Exhaust	SIDE EXHAUST		SIDE EXHAUST	
Sound dBA	87		89	
Vibration	0.7		1.0	



JAI-1044K	1/2" SQ. DR. Heavy-Duty Impact Wrench Kit
CONTENTS	1 PC JAI-1044 1/2" DR. Impact Wrench
	10 PCS CR-MO Socket Set 9, 10, 11, 13, 14, 17, 19, 22, 24, 27mm
	1 PC CR-MO 125mm Extension Bar
	1 PC 1/4" Mini Oiler
	1 PC T27 STAR HEX. KEY WRENCH
	1 PC 1/4" Air Nipple
	1 PC Oil Pot
	1 PC Blow Case



JAI-1054	1/2" SQ. DR. Heavy-Duty Impact Wrench
TECHNICAL DATA	JAI-1054
Square Drive	1/2"
Std Bolt Size	5/8" (M16)
Free Speed (rpm)	7,000
Working Torque (Ft-lb)	580 (780 N.M.)
Max. Torque (Ft-lb)	680 (920 N.M.)
Overall Length	8-1/16" (205 mm)
Air Inlet Size (PT)	1/4"
Air Hose (I.D.)	3/8"
Avg. Air Consumption (cfm)	4.2 (119 l/min)
Net Weight (kgs)	2.97 (6.6 lbs)
Noise Level (dB)	90
Vib. (M/S ²)	4.3
Clutch Mechanism	Twin Hammer
Exhaust Direction	Rear Exhaust



JAI-6202	1/2" Professional Air Impact Wrench
TECHNICAL DATA	JAI-6202
Square Drive	1/2"
Std Bolt Capacity	5/8" M16
Free Speed (RPM)	7000
Max. Torque	380 Ft/Lbs 516 N.M.
Overall Length	7-1/2" 190 MM
Air Inlet	1/4"
Air Hose (I.D.)	3/8" 9.5 MM
Air Pressure	90 PSI 6.2 BAR
Air Consumption	4.2 CFM 119.9 L/MIN
Anvil Length	STANDARD
Clutch Mechanism	PIN CLUTCH
Weight	5.9 LBS 2.7 KGS
Exhaust	SIDE EXHAUST



JAI-1044	1/2" SQ. DR. Heavy-Duty Impact Wrench
TECHNICAL DATA	JAI-1044
Square Drive	1/2"
Std Bolt Size	5/8" (M16)
Free Speed (rpm)	8,000
Working Torque (Ft-lb)	480 (650 N.M.)
Max. Torque (Ft-lb)	580 (780 N.M.)
Overall Length	7-15/16" (202 mm)
Air Inlet Size (PT)	1/4"
Air Hose (I.D.)	3/8"
Avg. Air Consumption (cfm)	4.2 (119 l/min)
Net Weight (kgs)	2.79 (6.1 lbs)
Noise Level (dB)	90
Vib. (M/S ²)	3.6
Clutch Mechanism	Twin Hammer
Exhaust Direction	Rear Exhaust



JAI-6202K	17Pcs 1/2" Air Impact Wrench Kit
CONTENTS	1 PC JAI-6202 1/2" Impact Wrench (Pin Clutch)
	10 PCS CR-MO Socket Set 9, 10, 11, 13, 14, 17, 19, 22, 24, 27 mm
	1 PC CR-MO 125 mm Extension Bar
	1 PC 1/4" Mini Oiler
	1 PC 4 mm Hex Key Wrench
	1 PC 1/4" Air Nipple
	1 PC Oil Pot
	1 PC Blow Case



- Twin Hammer Mechanism provides more power and smooth impact blows.
- Steel hammer case provides maximum protection.
- Two-Piece construction for easy service and trouble-free operation.

JAI-0501 1/2" Heavy Duty Air Impact Wrench

TECHNICAL DATA	JAI-0501
Square Drive	1/2" (12.7 mm)
Std Bolt Capacity	3/4" (18 mm)
Net Weight	5.8 lbs (2.66 kgs)
Length	7-1/4" (183 mm)
Avg. Air Cons.	4.6CFM (130 L/MIN)
Air Inlet	1/4"
Hose Size	3/8" (9.5 mm)
Air Pressure	90 PSI (6.3 kg/cm ²)
Max. Torque	450 Ft-Lbs (610N.M.)
Free Speed	7,000 r.p.m.
Exhaust	HANDLE EXHAUST
Clutch Mechanism	Twin Hammer

JAI-0501K 17Pcs 1/2" Air Impact Wrench Kit

CONTENTS	
1 PC	JAI-0501 1/2" Impact Wrench Twin Hamer
10 PCS	CR-MO Socket Set 9,10, 11, 13, 14, 17, 19, 22, 24, 27mm
1 PC	CR-MO 125mm Extension Bar
1 PC	1/4" Mini Oiler
1 PC	4mm Hex Key Wrench
1 PC	1/4" Air Nipple
1 PC	Oil Pot
1 PC	Blow Case



JAI-0405 1/2" Heavy Duty Impact Wrench

TECHNICAL DATA	JAI-0405
Square Drive	1/2" (12.7 mm)
Std Bolt Capacity	3/4" (19 mm)
Net Weight	5.9 lbs (2.66 kgs)
Max. Torque	500 Ft-Lbs (680N.M.)
Avg. Air Cons.	4.5 CFM (127.4 L/min)
Air Inlet	1/4"
Hose Size	3/8" (10 mm)
Air Pressure	90 psi (6.2 kg/cm ²)
Free Speed	7,000 r.p.m.
Exhaust	FRONT EXHAUST
Clutch Mechanism	Twin Hammer

JAI-0405K 17Pcs 1/2" Heavy Duty Impact Wrench Kit

CONTENTS	
1 PC	JAI-0405 1/2" Heavy Duty Impact Wrench
10 PCS	CR-MO Socket Set 9,10, 11, 13, 14, 17, 19, 22, 24, 27mm
1 PC	CR-MO 125mm Extension Bar
1 PC	1/4" Mini Oiler
1 PC	5mm Hex Key Wrench
1 PC	1/4" Air Nipple
1 PC	Oil Pot
1 PC	Blow Case



AIR RATCHET, DRILL & SCREWDRIVER SERIES

"SUPER DUTY AIR RATCHET WRENCH" the patent design of close type ratchet housing prolongs its endurance. The tool also has several useful functions including durable planetary gear unit, powerful motor unit, ergonomic trigger and housing design, 360° adjustable air inlet, comfortable soft material grip... etc.

Market Sales Application:

Ideal for industrial production line and maintenance market, such as machine equipment & vehicle... etc.

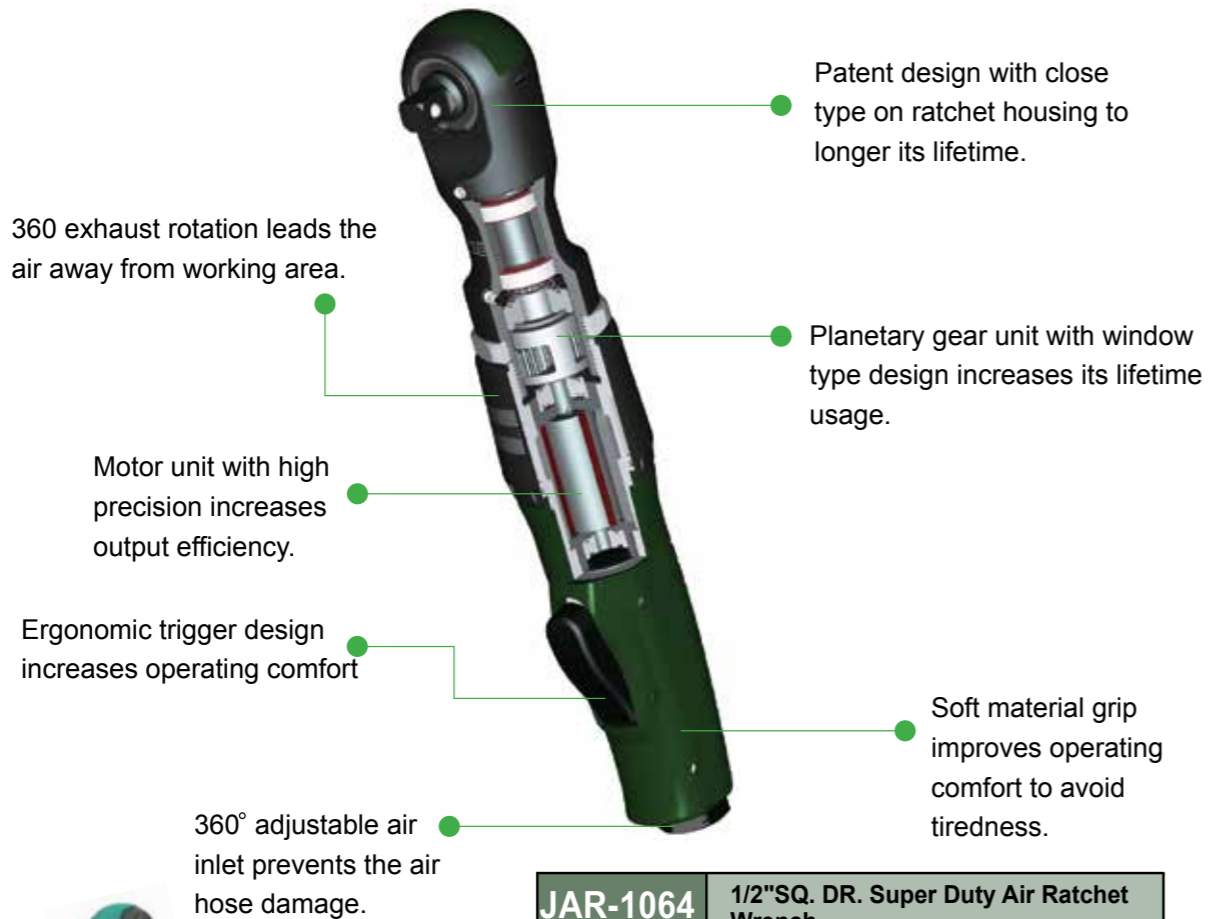

JAR-1064 1/2"SQ. DR. Super Duty Air Ratchet Wrench

TECHNICAL DATA	JAR-1064	
Square Drive	1/2"	
Std Bolt Size	3/8"	M10
Free Speed (rpm)	280	
MAX. Torque	80 (Ft-lb)	108 (N.M.)
Overall Length	10-29/32"	277(mm)
Air Inlet Size (PT)	1/4"	
Air Hose (I.D.)	3/8"	
Avg. Air Consumption	4 (cfm)	113 (l/min)
Net Weight	2.7 (lbs)	1.24 (kgs)
Noise Level (dB)	98	
Vib. (M/S ²)	5.3	



JAR-6309A 1/2" Heavy Duty Air Ratchet Wrench
JAR-6310A 3/8" Heavy Duty Air Ratchet Wrench

TECHNICAL DATA	JAR - 6309A		JAR - 6310A	
Square Drive	1/2"		3/8"	
Std Bolt Capacity	3/8"	M10	3/8"	M10
Free Speed (RPM)	170		170	
Max Torque	75 Ft/Lbs	100 N.M.	75 Ft/Lbs	100 N.M.
Overall Length	10 -3/4"	275 MM	10 -3/4"	275 MM
Air Inlet	1/4"		1/4"	
Air Hose (I.D.)	3/8"	9.5 MM	3/8"	9.5 MM
Air Pressure	90 PSI	6.2 BAR	90 PSI	6.2 BAR
Air Consumption	4 CFM	113 L/MIN	4 CFM	113 L/MIN
Weight	3.1 LBS	1.4 KGS	2.9 LBS	1.3 KGS
Exhaust	REAR		REAR	
Noise Level (dBA)	87			
Vibration (M/S ²)	5.58			



JAR-6309AK 1/2" Heavy Duty Air Ratchet Wrench Kit

CONTENTS	
	1 PC JAR -6309A Heavy Duty Air Ratchet Wrench
	7 PCS Socket Set 1/2"DR. 9, 10, 11, 13, 14, 17, 19 MM
	1 PC 75MM Extension Bar
	1 PC 1/2" or 3/8"Square Universal Joint
	1 PC 1/2" or 3/8" Square Bits Holder
	3 PCS Screwdriver Bits
	1 PC Blow Case



JAR-6311-1 1/2" Heavy Duty Air Ratchet Wrench
JAR-6311 3/8" Heavy Duty Air Ratchet Wrench

TECHNICAL DATA	JAR-6311-1		JAR-6311	
Square Drive	1/2"		3/8"	
Std Bolt Capacity	7/16"	M11	7/16"	M11
Free Speed (RPM)	650		650	
Max Torque	76 Ft/Lbs	102 N.M.	76 Ft/Lbs	102 N.M.
Overall Length	11.8"	300 MM	11.8"	300 MM
Air Inlet	1/4"		1/4"	
Air Hose (I.D.)	3/8"	9.5 MM	3/8"	9.5 MM
Air Pressure	90 PSI	6.2 BAR	90 PSI	8.2 BAR
Air Consumption	3.2 CFM	90 L/MIN	3.2 CFM	90 L/MIN
Weight	3.52LBS	1.6 KGS	3.52LBS	1.6 KGS
Exhaust	REAR		REAR	

*PIN CLUTCH-REACTIONLESS



JAR-6313	3/8" Stubby Air Ratchet Wrench
JAR-6312	1/4" Stubby Air Ratchet Wrench

TECHNICAL DATA	JA R- 6313		JA R- 6312	
Square Drive	3/8"		1/4"	
Std Bolt Capacity	3/8"	M10	3/8"	M10
Free Speed (RPM)	230		230	
Max Torque	25 Ft/Lbs	34 N.M.	25 Ft/Lbs	34 N.M.
Overall Length	6-1/2"	165 MM	6-1/2"	165 MM
Air Inlet	1/4"		1/4"	
Air Hose (I.D.)	3/8"	9.5 MM	3/8"	9.5 MM
Air Pressure	90 PSI	6.2 BAR	90 PSI	6.2 BAR
Air Consumption	3 CFM	85 L/MIN	3 CFM	85 L/MIN
Weight	1.1 LBS	0.5 KGS	1.1 LBS	0.5 KGS
Exhaust	REAR		REAR	
Noise Level (dBA)	90.6			
Vibration (M/S ²)	5.9			



JAD-1015	Air Spot Weld Drill W/Hook
-----------------	-----------------------------------

TECHNICAL DATA	JAD-1015	
Free Speed (RPM)	1800	
Air Pressure	90 PSI	6.2 BAR
Air Consumption	10 CFM	283 L/MIN
Air Inlet	1/4"	
Drill Capacity (Dia.)	5/16"	8 MM
Hose Size (I.D.)	3/8"	9.5 MM
Length	10"	254 MM
Weight	4.6 LBS	2.1 KGS



JAD-1021	3/8" Air Angle Drill
-----------------	-----------------------------

TECHNICAL DATA	JAD-1021
Free Speed (RPM)	1900
Chuck Capacity (MM)	10 mm (3/8")
Air Inlet	1/4"
Air Pressure Bar	90 PSI
Air Consumption (CFM)	280 L/MIN
Net Weight	0.96 kg
Length x Height	190 x 110 mm
Exhaust System	REAR



JAD-6252A	3/8" Air Straight Drill
------------------	--------------------------------

TECHNICAL DATA	JAD - 6252A	
Free Speed (RPM)	2500	
Capacity of Chuck	3/8"	9.5 MM
Air Inlet	1/4"	
Hose Size (I.D.)	3/8"	9.5MM
Air Pressure	90 PSI	6.2 BAR
Air Consumption	4 CFM	113 L/MIN
Spindle Thread	3/8"- 24UNF	
Length	9"	228 MM
Weight	2 LBS	0.9 KGS



JAD-6246	Air Spot Weld Drill
-----------------	----------------------------

TECHNICAL DATA	JAD - 6246	
Free Speed (RPM)	1800	
Air Pressure	90 PSI	6.2 BAR
Air Consumption	10 CFM	283 L/MIN
Air Inlet	1/4"	
Drill Capacity (Dia.)	5/16"	8 MM
Hose Size (I.D.)	3/8"	9.5 MM
Length	10"	254 MM
Weight	3.74 LBS	1.7 KGS



JAD-6233	3/8" Air Drill
JAD-6234	3/8" Air Reversible Drill

TECHNICAL DATA	JAD - 6233		JAD - 6234	
Free Speed (RPM)	2500		1800	
Capacity of Chuck	3/8"		3/8"	
Air Inlet	1/4"		1/4"	
Hose Size (I.D.)	3/8"		3/8"	
Air Pressure	90 PSI	6.2 BAR	90 PSI	6.2 BAR
Air Consumption	4 CFM	113 L/MIN	4 CFM	113 L/MIN
Spindle Thread	3/8"- 24UNF		3/8"- 24UNF	
Length	6-1/2"	165 MM	6-1/2"	165 MM
Weight	2.5 LBS	1.1 KGS	2.5 LBS	1.1 KGS



JAD-6246K	10Pcs Air Spot Weld Drill Kit
------------------	--------------------------------------

CONTENTS	
	1 PC JAD - 6246 Air Spot Weld Drill
	1 PC Mini Oiler
	1 PC Swivel Connector (1/4"x1/4")
	4 PCS Extra 8MM & 6.5MM Drill Bit
	1 PC Air Nipple
	1 PC 2.5MM "L" Type Hex Key Wrench
	1 PC Blow Case



Tool-free adjustable torque control
Ergonomic design handle
Two step trigger control
360° adjustable air inlet
Rear exhaust design
Hanging ring design (Hanger design)



JAB-2051	Shut-Off Torque Control Screwdrivrer
JAB-2052	Shut-Off Torque Control Screwdrivrer

TECHNICAL DATA	JAB-2051	JAB-2052
Capacity (mm)	4	3.5
Free Speed (RPM)	1400	1400
Torque Range (N.m.)	1.4~2.6	0.9~1.6
Overall Length (mm)	195	195
Weight (kgs)	0.95	0.95
Air Inlet Size	1/4"	1/4"
Air Pressure (psi)	90	90
Noise Level (dB)	80	80
Air Consumption (CFM)	7	7



JAB-7023	Pistol Reversible Adjustable Air Screwdriver
-----------------	---

TECHNICAL DATA	JAB - 7023	
Hex Size of Bit	1/4"	6.35 MM
Capacity of Screw	M5	
Free Speed (RPM)	800	
Max Torque IN-LBS	45-145	
Overall Length	8-1/2"	216 MM
Air Inlet	1/4"	
Air Hose (I.D.)	3/8"	
Air Pressure	90 PSI	6.2 BAR
Air Consumption	4 CFM	113 L/MIN
Clutch Mechanism	Internal Adjustable Clutch	
Weight	2.67 LBS	1.21 KGS

AIR DIE GRINDER SERIES





JAG-0903R	1/4" Heavy Duty Mini Air Die Grinder
JAG-0903RM	6mm Heavy Duty Mini Air Die Grinder

TECHNICAL DATA	JAG-0903R	JAG-0903RM
Free Speed (RPM)	25000	
Motor	0.21 KW	0.3 HP
Collet Size	1/4"	6 MM
Overall Length	6"	152 MM
Air Inlet	1/4"	
Air Hose (I.D.)	3/8"	
Air Pressure	90 PSI	6.2 BAR
Air Consumption	4 CFM	113 L/MIN
Exhaust System	REAR	
Weight	0.77 LBS	0.35 KGS

JAG-0903RK	1/4" Mini Air Die Grinder Kit
-------------------	--------------------------------------

CONTENTS	
	1 PC JAG-0903 Mini Die Grinder
	5 PCS 1/4" (6mm) Shank Mounted Stone
	5 PCS 1/8" (3mm) Shank Mounted Stone
	2 PCS Open Wrench
	1 PC 1/8" (3mm) Reducer
	1 PC Blow Case

- Lightweight, compact size is easy to handle.
- Safety lever throttle.
- Composite sleeve for comfortable TPR handle.
- Rear Exhaust keeps air away from you and your working area.
- Built-in the silencer and regulator.



JAG-0906R	1/4" Heavy Duty Medium Air Die Grinder
JAG-0906RM	6mm Heavy Duty Medium Air Die Grinder
JAG-0906F	1/4" Heavy Duty Medium Air Die Grinder

TECHNICAL DATA	JAG-0906R	JAG-0906RM	JAG-0906F
Free Speed (RPM)	22000		
Motor	0.29 KW	0.4 HP	0.42 KW
Collet Size	1/4"	6 MM	1/4"
Overall Length	6.8"	175 MM	5.7"
Air Inlet	1/4"		1/4"
Air Hose (I.D.)	3/8"		
Air Pressure	90 PSI	6.2 BAR	90 PSI
Air Consumption	4 CFM	112 L/MIN	4 CFM
Exhaust System	REAR		FRONT
Weight	1.3 LBS	0.6 KGS	1.17 LBS
Noise Level (dBA)	92.3		
Vibration (M/S ²)	2.5		

JAG-0906RMK	6mm Air Die Grinder Kit
--------------------	--------------------------------

CONTENTS	
	1 PC JAG-0906RM Medium Die Grinder
	5 PCS 1/4" (6mm) Shank Mounted Stone
	5 PCS 1/8" (3mm) Shank Mounted Stone
	2 PCS Open Wrench
	1 PC 1/8" (3mm) Reducer
	1 PC Blow Case

- Power motor provides good job.
- Safety lever throttle.
- Rear Exhaust keeps air away from you and your working area.
- Built-in the silencer and regulator.
- Comfortable TPR handle.



JAG-0913R	1/4" Heavy Duty Mini Angle Air Die Grinder
JAG-0913RM	6mm Heavy Duty Mini Angle Air Die Grinder

TECHNICAL DATA	JAG-0913R	JAG-0913RM
Free Speed (RPM)	18000	
Motor	0.21 KW	0.3 HP
Collet Size	1/4"	6 MM
Overall Length	6.1"	155 MM
Air Inlet	1/4"	
Air Hose (I.D.)	3/8"	
Air Pressure	90 PSI	6.2 BAR
Air Consumption	3 CFM	85 L/MIN
Exhaust System	REAR	
Weight	1.08 LBS	0.49 KGS

- Lightweight, compact size is easy to handle.
- Safety lever throttle.
- Composite sleeve for comfortable TPR handle.
- Rear Exhaust keeps air away from you and your working area.
- Built-in the silencer and regulator.



JAG-0976RM	7" Extension 6mm Air Die Grinder
-------------------	---

TECHNICAL DATA	JAG-0976RM
Free Speed (RPM)	22000
Motor	0.6 HP
Collet Size	6 MM
Overall Length	260 MM
Air Inlet	1/4"
Air Hose (I.D.)	3/8"
Air Pressure	6.2 BAR
Air Consumption	112 L/MIN
Exhaust System	REAR
Weight	0.64 KGS

- Lightweight, compact size is easy to handle
- Safety lever throttle
- Composite sleeve for comfortable TPR handle
- A built-in silencer and regulator



JAG-0973R	7" Extension 1/4" Air Die Grinder
JAG-0973RM	7" Extension 6mm Air Die Grinder

TECHNICAL DATA	JAG-0973R	JAG-0973RM
Free Speed (RPM)	20000	
Motor	0.21 KW	0.3 HP
Collet Size	1/4"	6 MM
Overall Length	11.13"	282 MM
Air Inlet	1/4"	
Air Hose (I.D.)	3/8"	
Air Pressure	90 PSI	6.2 BAR
Air Consumption	4 CFM	113 L/MIN
Exhaust System	REAR	
Weight	2 LBS	0.9 KGS

- Heavy Duty
- Safety lever throttle
- Composite sleeve for comfortable TPR handle
- Keeps air away from you and your work area using a rear exhaust
- built-in the silencer and regulator



JAG-0806R	1/4" Heavy Duty Air Die Grinder
JAG-0806RM	6mm Heavy Duty Air Die Grinder

TECHNICAL DATA	JAG-0806R		JAG-0806RM	
Free Speed (RPM)	4000		4000	
Motor	0.42 KW	0.6 HP	0.42 KW	0.6 HP
Collet Size	1/4"		6 MM	
Overall Length	9"	220 MM	9"	220 MM
Air Inlet	1/4"		1/4"	
Air Hose (I.D.)	3/8"		3/8"	
Air Pressure	90 PSI	6.2 BAR	90 PSI	6.2 BAR
Air Consumption	10.6 CFM	300 l/min	10.6 CFM	300 l/min
Exhaust System	REAR		REAR	
Weight	1.6 lbs	0.75 kgs	1.6 lbs	0.75 kgs



JAG-6638	5" Professional Air Angle Grinder (Lever Throttle)
JAG-6612	4" Professional Air Angle Grinder (Lever Throttle)

TECHNICAL DATA	JAG-6638	JAG-6612
Free Speed RPM	11000	11000
Capacity Bolt Size	IN	5"
	MM	125
Overall Length	IN	9
	MM	230
Air Inlet (PT)	1/4"	1/4"
Air Hose (ID)	3/8"	3/8"
Work Air Pressure	PSI	90
	BAR	6.2
Avg. Air Consumption	CFM	6
	L/MIN	170
Net Weight	LBS	4.0
	KGS	1.8
Power KW (HP)	0.7 (0.93)	0.7 (0.93)
Spindle Thread	5/8"-11UNC	3/8"-24UNC
Sug. Air Comp (HP)	2	2



JAG-6608	22000 RPM Micro Air Grinder
-----------------	------------------------------------

TECHNICAL DATA	JAG-6608
Free Speed (RPM)	22000
Capacity	30 MM PAD
Air Inlet	1/4"
Air Hose (I.D.)	5 MM
Work Air Pressure	90 PSI / 6.2 BAR
Avg. Air Consumption	0.1m³/min
Net Weight	0.203 kgs
Dimensions (MM)	16.5 x 136



JAH-6833H	250mm Air Hammer (Hex)
------------------	-------------------------------

TECHNICAL DATA	JAH-6833H	
Chisel Shank	Round	-
	Hex	0.410"
Bore Diameter (I.D.)	3/4"	19 MM
Piston Stroke Length	3.5"	90 MM
Blow Per Min. (BPM)	2100	
Overall Length	8.7"	220 MM
Air Inlet	1/4"	
Air Hose (I.D.)	3/8"	
Air Pressure	90 PSI	6.2 BAR
Air Consumption	7.4 CFM	210 L/MIN
Weight	4.4 LBS	2 KGS



JAG-0707	60000 RPM Micro Air Grinder
-----------------	------------------------------------

TECHNICAL DATA	JAG-0707
Free Speed (RPM)	60000
Capacity	Option: 3MM, 1/8" , 3/32"
Air Inlet	1/4"
Air Hose (I.D.)	6.35 MM
Work Air Pressure	90 PSI / 6.2 BAR
Avg. Air Consumption	0.08m³/min
Net Weight	0.132 kgs
Dimensions (MM)	21 x 155



JAH-6833HK	8 Pcs 250mm Air Hammer Kit (Hex)
-------------------	---

CONTENTS	
	1 PC JAH- 6833H Air Hammer
	1 PC Spring retainer
	5 PCS 7" CR- MO Chisel
	JAZ - 3901(H) Panel Cutter
	JAZ - 3904(H) Spot Weld Cutter
	JAZ - 3934(H) Tapered Punch
	JAZ - 3903(H) Flat Chisel
	JAZ - 3935(H) Single End Cutter
	1 PC BLOW CASE

PROFESSIONAL AIR SANDER SERIES

AIR DIE GRINDER SERIES

CE



JAH-0288 Air Needle Scaler	
TECHNICAL DATA	JAH - 0288
No. of Needle	12 PCS
Blow Per Min. (BPM)	5,000
Overall Length	11.4" 290 MM
Air Inlet	1/4"
Air Pressure	90 PSI
Air Consumption	49 L/MIN
Piston Size	18 X 14MM
Weight	1.3 KGS
Needle Diameter (MM)	3 X 125
Piston Stroke	32MM

CE



JAH-6836 Air Needle Scaler	
TECHNICAL DATA	JAH-6836
Blow Per Min. (BPM)	4600
Needle Diameter (mm)	3 X 180
Numbers of Needles	19 pcs
Air Inlet	1/4"
Air Pressure (BAR)	6.2
Air Consumption (L/MIN)	232
Weight (kg)	2.8
Overall Length (mm)	460
Piston	25.4 x 43.5
Sound Pressure Level	92.26 dBA
Sound Power Level	104.3 dBA
Vibration Level	10.2 M/Sec ²
Piston Stroke	38MM (1.5")

CE



JAH-7105 Needle Scaler	
TECHNICAL DATA	JAH-7105
Weight	2.7 kg
Length	10"
Air Consumption	3 CFM
Air Pressure	90 PSI
Air Inlet	1/4"
Blow Per Minute	3700
Piston (mm)	23.5 X 20 X 73
Numbers of Needles	(Φ2 X 29pcs), Φ3 X 19pcs
Sound Pressure Level	97.0 dBA
Sound Power Lever	103.8 dBA
Vibration Level	8.7 M/Sec ²

CE



JAH-7102C Mini Air Chipping Hammer (Round)	
TECHNICAL DATA	JAH-7102C
Piston Diameter	25/32" 20 mm
Piston Stroke	1-49/64" 45 mm
Blow Per Min (BPM)	3000
Overall Length	9-9/16" 243 mm
Air Inlet	1/4"
Air Hose (I.D.)	3/8"
Air Pressure	90 PSI 6.2 BAR
Air Consumption	6 CFM 170 L/MIN
Sug. Air Comp (HP)	1.5 HP
Chisel Shank	ROUND 14 mm
Weight	5.7 LBS 2.6 KGS

• Standard Type of Retainer





JAS-1207-6HE 6" Composite Mini Random Orbital Sanders

TECHNICAL DATA	JAS-1207-6HE
Vac. system	Self-Gen Vac.
Free Speed PRM	12,000
Orbit Dia	3/16in.
Motor	0.28hp 209w
Pad Dim	6in. 152mm
Air Flow	17CFM (481L /MIN)
Product Net Wt.	1.94Lbs 0.88kg
Height	3.3in. 83mm
Length	9.1in. 232mm
Face Pad	HOOK



JAS-6697-5HE 5" Central-Vacuum Random Orbital Air Sander
JAS-6697-6HE 6" Central-Vacuum Random Orbital Air Sander

TECHNICAL DATA	JAS- 6697- 5HE	JAS- 6697- 6HE
Pad Size	5"	6"
Free Speed (RPM)	9000	9000
Orbit Dia.	5 MM	5 MM
Air Inlet	1/4"	1/4"
Air Hose (I.D.)	3/8"	3/8"
Air Pressure	5 - 7 KG/CM ²	5 - 7 KG/CM ²
Air Consumption	13.4 CFM	13.4 CFM
Weight	2.4 LBS	2.4 LBS
Face Pad	HOOK	HOOK

Optional Orbital Dia : 3MM



JAS-1208-5HE 5" Air Polishing Sander

TECHNICAL DATA	JAS-1208-5HE
Pad Dia.	5"
Air Inlet	1/4"
Air Hose(I.D.)	3/8"
Air Pressure(psi)	90
Pad Face	HOOK
Free Speed (rpm)	2,400
Air Consumption. cfm(l/min)	6(170)
Weight (kg)	0.8



JAS-6698-5HE 5" Self Generated Vacuum Random Orbital Air Sander
JAS-6698-6HE 6" Self Generated Vacuum Random Orbital Air Sander

TECHNICAL DATA	JAS- 6698- 5HE	JAS- 6698- 6HE
Pad Size	5"	6"
Free Speed (RPM)	9000	9000
Orbit Dia.	5 MM	5 MM
Air Inlet	1/4"	1/4"
Air Pressure	5 - 7 KG/CM ²	5 - 7 KG/CM ²
Air Consumption	380 L/MIN	380 L/MIN
Weight	1.04 KGS	1.05 KGS
Face Pad	HOOK	HOOK

Optional Orbital Dia : 3MM



JAS-6534-6HE 6" Self Generated Vacuum Random Orbital Air Sander

TECHNICAL DATA	JAS-6534-6HE
Pad Size	6"(150 MM)
Free Speed (RPM)	10000
Orbit Dia.	5 MM (3/16")
Air Inlet	1/4"
Air Hose (I.D.)	3/8"
Air Pressure	90 PSI / 6.2 BAR
Air Consumption	0.3 m ³ / min / 11.9 CFM
Weight	1.02 KG
Face Pad	HOOK

- Four Bearing Special Design
- Well Balance
- Anti-Dust
- Optional Orbital Dia : 2.5MM
- Comfortable Grip
- Durable
- Powerful Vacuum Suction System



JAS-1033-6HE 6" Dust Free Type Orbital Air Sander

TECHNICAL DATA	JAS-1033-6HE
Pad Size	6"(150 MM)
Free Speed (RPM)	10000
Orbit Dia.	7
Air Inlet	1/4"
Air Hose (I.D.)	3/8"
Air Pressure	90 PSI
Air Consumption	0.4 m ³ /min
Spindle Thread	5/16-24 UNF
Face Pad	HOOK



The New Advance Air Belt Sanders and Cut-Off Tool have the same housing which provides unique functions to increase performance highly. . The soft material grip on the housing improves operating comfort and reduces tiredness for long time usage. Also the special design of user friendly enhance the work efficiency.

Market Sales Application:

The new ideal design for finishing metal surface like metal cart products, stone & wood products, plastic products, glass and earthenware...etc. And the Cut-Off tool is for cutting plate.

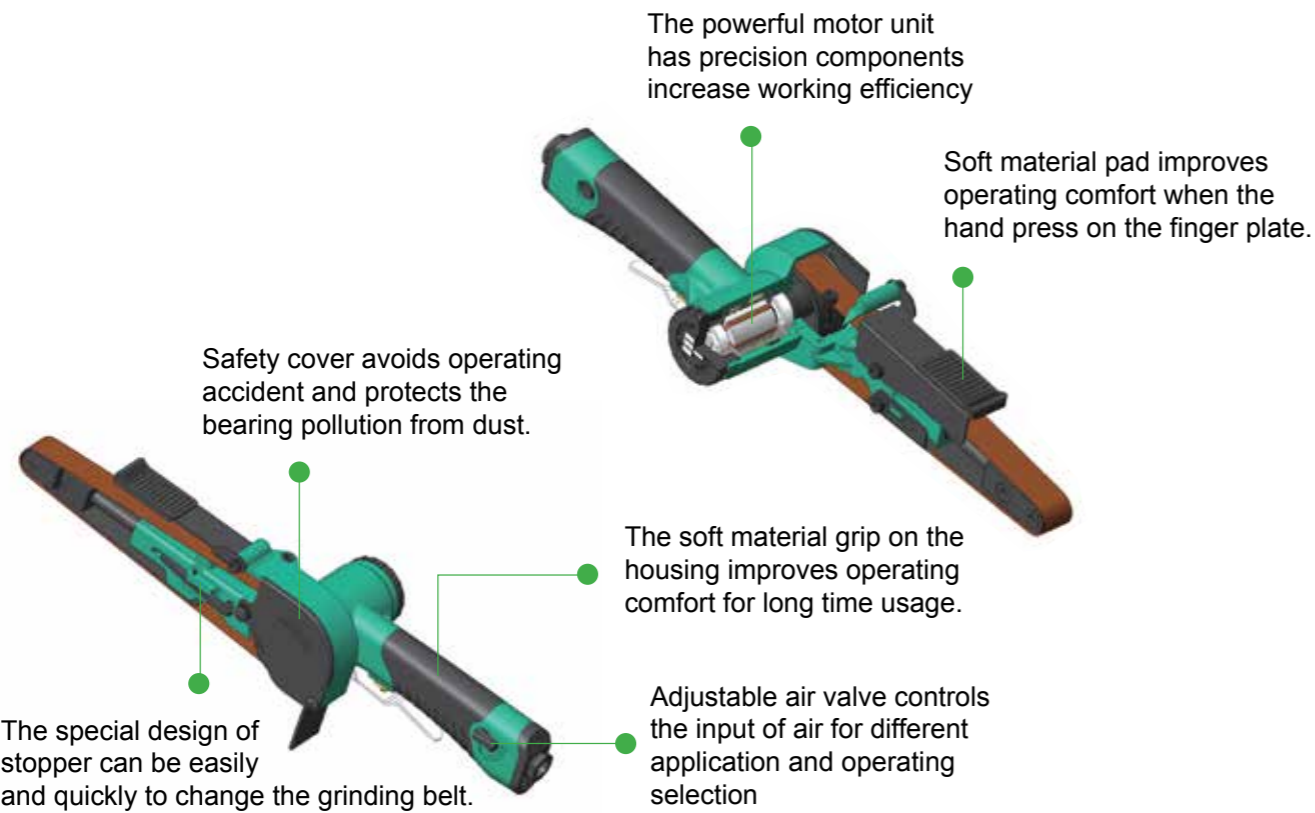

JAS-0452 AIR BELT SANDER(20X520mm) & W/2 pcs Belts(#80,#100)

TECHNICAL DATA	JAS-0452
Free Speed	16,000 rpm
Size of Belt	20 x 520 mm
Air Consumption	4 CFM
Horsepower	0.5 HP
Overall Length	430 mm
Net Weight	1.4 kg
Air Inlet Size	1/4"
Air Hose (I.D)	3/8" 10mm
Air Pressure	90PSI 6.2BAR
Vibration (M/S ²)	2.8
Noise Level (dBA)	95



JAS-6542 Air Belt Sander (20 X 520mm)

TECHNICAL DATA	JAS-6542	
Sanding Paper	7/8" x 20"	
	20 x 520 MM	
Free Speed (RPM)	16000	
Overall Length	14-1/5"	
	360 MM	
Air Inlet	1/4"	
Air Hose (I.D.)	3/8"	
Air Pressure	90 PSI	6.2 BAR
Air Consumption	9 CFM	254 L/MIN
Weight	2.6 LBS	1.2 KGS
Noise Level (dBA)	79.5	
Vibration (M/S ²)	4.5	



JAS-6552 7" Air Vertical Polisher

TECHNICAL DATA	JAS-6552	
Disc Size	7"	178 MM
Spindle Size	5/8" - 11UNC	
Free Speed (RPM)	2500	
Overall Length	7-1/2"	190 MM
Air Inlet	1/4"	
Air Hose (I.D.)	3/8"	
Air Consumption	6 CFM	170 L/MIN
Air Pressure	90 PSI	6.2 BAR
Suggested Air Compressor	2 HP	
Weight	6.1 LBS	2.8 KGS



JAS-1009 6" Dual Action Air Sander (Vinyl)

TECHNICAL DATA	JAS-1009	
Pad Size	6"	
Free Speed (RPM)	10000	
Air Inlet	1/4"	
Air Hose (I.D.)	3/8"	
Air Pressure	90 PSI	6.2 BAR
Air Consumption	5 CFM	140 L/MIN
Spindle Thread	5/16" - 24 UNF	
Weight	4.8 LBS	2.2 KGS
Face Pad	Vinyl	



JAS-6660 2" Diamond Air Sander
JAS-6660-3 3" Diamond Air Sander

TECHNICAL DATA	JAS-6660		JAS-6660-3	
Pad Size	2"	50 MM	3"	75 MM
Free Speed (RPM)	10000		10000	
Orbit Dia.	3 MM		3 MM	
Air Inlet	1/4"		1/4"	
Air Hose (I.D.)	3/8"		3/8"	
Air Pressure	90 PSI	6.2 BAR	90 PSI	6.2 BAR
Air Consumption	11.6 CFM	330 L/MIN	11.6 CFM	330 L/MIN
Weight	1.54 LBS	0.7 KGS	1.54 LBS	0.7 KGS

CE
Vibration Free!!



JAT-1010 Low Vibration Mechanism Air Saw

TECHNICAL DATA	JAT-1010
Blow Per Minute (BPM)	10,000
Stroke Length (MM)	10
Avg. Air Consumption	6 CFM
Net Weight	0.72 Kgs
Air Inlet	1/4" NPT (PT)
Air Hose Size	O.D. 3/8"
Vibration	9.0 m/s ²
Sound Pressure	85 dBA



JAT-6946 Air Body Saw (Rear Exhaust)	
TECHNICAL DATA	JAT-6946
Blow Per Minute (BPM)	5000
Stroke Length	10 MM
Capacity Cutting Size	Steel 1.2 MM
Air Inlet	1/4"
Air Pressure	6.2 BAR
Air Consumption	230 L/MIN
Overall Length	250 MM
Weight	1.1 KGS



JAT-6676 Air Body Saw (Rear Exhaust)	
TECHNICAL DATA	JAT-6676
Blow Per Minute (BPM)	9000 - 10000
Air Consumption	8.2 CFM 230 L/MIN
Air Inlet	1/4"
Air Pressure	90 PSI 6.2 BAR
Size of Belt	10 X 330 MM
Stroke Length	10 MM
Cutting Capacity	STEEL 1.6MM THICKNESS
Overall Length	235 MM
Blade Shaft	1.2 -1.6 MM
Weight	2.2 LBS 1.0 KGS
Exhaust	REAR



JAT-1010K Low Vibration Mechanism Air Saw Kit

CONTENTS :

- 1PC-JAT-1010 LOW VIBRATION MECHANISM AIR SAW
- 5PCS-18 TEETH SAW BLADES
- 5PCS-24 TEETH SAW BLADES
- 5PCS-32 TEETH SAW BLADES

FEATURES :

- Designed with following patents to assure Extreme Low Vibration and operator comfort
- Portable Pneumatic Tool assembled with module units
- Suspension Vibration-Reducing means for portable pneumatic tools
- Patented quick change Blade Holder makes changing saw blades / files easily
- Lock off Throttle to prevent accidental start ups
- Adjustable Guard/Guide allows operators to set depth of cut
- Rear exhaust directs air away from work-piece



JAT-6679 Low Speed Air Tire Buffer (Rear Exhaust)	
TECHNICAL DATA	JAT-6679
Free Speed (RPM)	2500
Power	0.42 KW
Size of Q.C.	HEX 11.11 MM
Air Inlet	1/4"
Air Pressure	6.2 BAR
Air Consumption	350 L/MIN
Overall Length	228.6 MM
Exhaust System	REAR
Weight	0.91 KG



JAT-6673B 1/4" (6.4MM) Heavy Duty Air Hydraulic Riveter	
TECHNICAL DATA	JAT-6673B
Blind Rivet Setting Capacity	3/32" TO 1/4" (2.4 TO 6.4 MM)
Traction Power kg-F(Lb-F)	1700 (3740)
Stroke Length mm (inch)	18 (0.708")
Air Inlet PT (NPT)	1/4"
Air Hose (I.D.)	3/8"
Air Pressure	90 PSI (6.2 BAR)
Air Consumption	2.9 L / Cycle
Nose Piece	2.4 (3/32"), 3.2 (1/8"), 4.0 (5/32"), 4.8 (3/16"), 6.0, 6.4 (1/4")
Width x Height (mm)	170 X 298
Weight KGS (Lbs)	1.75 (3.9)



JAT-10T18	5 Pcs 18 Teeth Saw Blades
JAT-10T24	5 Pcs 24 Teeth Saw Blades
JAT-10T32	5 Pcs 32 Teeth Saw Blades

Max. Blind Rivet Seating Capacity (Head/Mandrel) : 6.4mm (Stainless-Stainless)
Only For JAT-6673B



JAT-6004K 6Pcs Air Grease Gun (400 CC)

CONTENTS	
	1. Gun Body JAT - 6004
	2. Hexagonal Spout
	3. Quick Coupler
	4. Hose Fitting
	5. 9" Nylon Hose
	6. Hand Operation Gun Handle Set



JAT-460 Lever Type Hand Grease Gun

TECHNICAL DATA	JAT-460
Capacity Bulk	400 CC.
Capacity Cartridge	14 OZ
Finish	Container Tube: Chrome Plated
Size (mm x mL)	56.4 x 350
Pressure Tested	Working Pressure: 310 Bar (4500 PSI)
Weight	1.02 Kgs



JAZ-6704 3/8" PT Air Filter, Regulator & Lubricator

TECHNICAL DATA	JAZ-6704
Port Size	3/8" PT
Applied Flure	Air of Pressure
Max. Pressure	10 kgf / cm ² (1400 kpa)
Range of Pressure	1.0 - 9.8 kgf / cm ²
Filteration	5 - 50 micron
Min. Dropped Flow	1250 L/MIN
Ambient Temperature	5° - 50° C
Discharge Method	Broken pressure auto discharge or hand discharge
Lubricating Method	Spraying from 30 L/MIN
Storage	120 C.C.
Usable Oil	VG- 32 or OM-300A
Weight	2.1 kgs



F.R.L. Combination unit

Technical Data	Port Size RC (PT)	Flow rate L/min (ANR)	Pressure Range Kg/cm ² (Kpa)	Filter Grade
JAZ-0514	1/2"	3000	0.5-8.5 (50-850)	5µm



F.R. Piggyback Unit

Technical Data	Port Size RC (PT)	Flow rate L/min (ANR)	Gauge Connection RC(PT)	Filter Grade
JAZ-0534	1/2"	3000	1/4"	5µm



JAT-6959	4" LONG NOSE ANGLE NOZZLE AIR BLOW GUN (100MM)
JAT-6959A	11" LONG NOSE ANGLE NOZZLE AIR BLOW GUN (280MM)

- Body Material: Nylon Fiber
- Nozzle Material: Steel
- Working Pressure: 75~120PSI / 5.0~8.0KGS
- Max Perssure: 160PSI
- Sound Pressure: 85-90dBA
- Thread Type: 1/4" NPT Female
1/4" PS Female
- Temperature Range: -40° TO 140° F



JAT-6905S AIR BLOW GUN W/ 6 PCS NOZZLES

- Ergonomic handle design for comfortable operation.
- Composite material housing for light weight.
- Durable construction increases long lifetime.
- Two smart hangers provide better tool storage and more convenient to use.
- 6 pcs of smart nozzle include several functions.
- Contents:
1PC-HOUSING
1PC-BIG AIR FLOW NOZZLE
1PC-1" NOZZLE
1PC-TRIANGLE NOZZLE
1PC-1/2" RUBBER NOZZLE
1PC-3" SAFE NOZZLE
1PC-4" NOZZLE

NO.	ITEM NO.	
A	JAT-6905A	AIR BLOW GUN W/ BIG AIR FLOW NOZZLE
B	JAT-6905B	AIR BLOW GUN W/1" NOZZLE
C	JAT-6905C	AIR BLOW GUN W/ TRIANGLE NOZZLE
D	JAT-6905D	AIR BLOW GUN W/1/2" RUBBER NOZZLE
E	JAT-6905E	AIR BLOW GUN W/3" SAFE NOZZLE
F	JAT-6905F	AIR BLOW GUN W/4" NOZZLE



JAT-6905A



JAT-6905B



JAT-6905C



JAT-6905D



JAT-6905E



JAT-6905F

PU ETHER - Hydrolysis Resistant Hose

- Excellent flexibility in cold weather softer than Ester in winter
- Resistant to attacks from moisture
- To Extend Service Life of Hose Reel 3 times longer than Ester
- Excellent weather resistance



JAZ-29510 Spring Driven Hose Reel (9.5MM X 10M)

TECHNICAL DATA	JAZ-29510
Air Hose (I.D.)	9.5 MM (3/8")
Max. Working Pressure At 23°C (75°F)	15 BAR
Bursting Pressure At 23°C (75°F)	60 BAR
Hose Length (inlet)	50 CM
Hose Length (outlet)	10 M
Hose Type	PU BRAID
Fitting Thread Size (inlet + outlet)	3/8 + 3/8
Weight (N.W.)	9.5 KGS



JAZ-0001A Auto Air - Hose Winder
9.5 x 13.5MM x 12M (3/8" x 40Ft)
JAZ-0001B Auto Air - Hose Winder
8 x 12MM x 15M (5/16" x 50Ft)



JAZ-0003B Heavy - Duty Retractable Cord Reel 50Ft (15M)



JAZ-0005A Auto - Winding Work Lamp
33 Ft (10M)

Material: Steel , Chrome plated (European Type , USA Type , Japanese Type ,etc . available

ONE TOUCH QUICK COUPLER		
	TECHNICAL DATA	THREAD SIZE
	SM-20A	PT 1/4", MALE
	SM-30A	PT 3/8", MALE

ONE TOUCH QUICK COUPLER		
	TECHNICAL DATA	THREAD SIZE
	SF-20A	PT 1/4", FEMALE
	SF-30A	PT 3/8", FEMALE

ONE TOUCH QUICK COUPLER		
	TECHNICAL DATA	THREAD SIZE
	SH-20A	5/16", HOSE BARB
	SH-30A	3/8", HOSE BARB

QUICK COUPLER		
	TECHNICAL DATA	INSIDE DIA OF HOSE
	SM-20	PT 1/4", MALE
	SM-30	PT 3/8", MALE
	SM-40	PT 1/2", MALE

QUICK COUPLER		
	TECHNICAL DATA	INSIDE DIA OF HOSE
	SF-20	PT 1/4", FEMALE
	SF-30	PT 3/8", FEMALE
	SF-40	PT 1/2", FEMALE

QUICK COUPLER		
	TECHNICAL DATA	INSIDE DIA OF HOSE
	SH-20	5/16", HOSE BARB
	SH-30	3/8", HOSE BARB
	SH-40	1/2", HOSE BARB

PLUG		
	TECHNICAL DATA	THREAD SIZE
	PM-20	PT 1/4", MALE
	PM-30	PT 3/8", MALE
	PM-40	PT 1/2", MALE

PLUG		
	TECHNICAL DATA	THREAD SIZE
	PF-20	PT 1/4", FEMALE
	PF-30	PT 3/8", FEMALE
	PF-40	PT 1/2", FEMALE

PLUG		
	TECHNICAL DATA	THREAD SIZE
	PH-20	5/16", HOSE BARB
	PH-30	3/8", HOSE BARB
	PH-40	1/2", HOSE BARB



JAZ-3811B Spring Balancer (0.6 - 1.5Kg)

TECHNICAL DATA	Capacity (kg)	Weight (kg)	Travel (m)	Rope Option	Rope Dia. (mm)	A (mm)	B (mm)
JAZ-3811B	0.6-1.5	0.52	1.6	Nylon/Cable	2.5	240	44

TECHNICAL DATA	DESCRIPTION	APPLIED TOOLS
JAZ-3714	QUICK CHANGE TYPE RETAINER	JAH-6832, JAH-6832H JAH-6833, JAH-6833H



TECHNICAL DATA	DESCRIPTION	APPLIED TOOLS
JAZ-3713	ZIP CHANGE TYPE RETAINER	JAH-6832, JAH-6832H JAH-6833, JAH-6833H



Pad For
JAS-6697, JAS-6689, JAS-6698

PU Sanding Pad (Thickness : 10mm, Hook Face)



- JAZ-0034D 6"x6 HOLE
- JAZ-0034B 5"x6 HOLE

PU Sanding Pad (Thickness : 8.5mm, Vinyl Face)



- JAZ-0045D 6"x6 HOLE
- JAZ-0045B 5"x6 HOLE

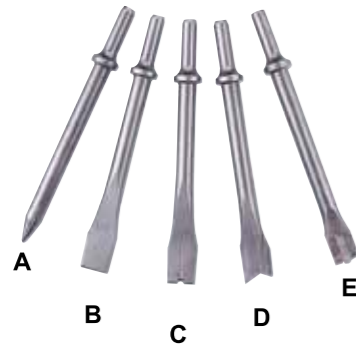

TECHNICAL DATA	DESCRIPTION	APPLIED TOOLS	PART NO.
JAZ-3945H	5PCS LONG CHISEL (HEX) SHANK : 0.39" L : 175MM	JAH-6832H JAH-6833H	A.JAZ- 3934 TAPERED PUNCH
			B.JAZ-3903 FLAT CHISEL
			C.JAZ- 3904 SPOT WELD CUTTER
			D.JAZ- 3935 SINGLE END CUTTER
			E.JAZ- 3901 PANEL CUTTER

SPRAY GUN SERIES





JA-HVLP-40	PROFESSIONAL H.V.L.P SPRAY GUN	
JA-HVLP-40W	PROFESSIONAL H.V.L.P SPRAY GUN (WATER BASE)	
TECHNICAL DATA		
Air Pressure Inlet	Bar	2
	Psi	29
Air Cap Pressure	Psi	<10
Air Inlet		1/4"
Fluid Inlet		M16x1.5P
Air Consumption	Cfm	10
	L/min	283
Weight Gun Only	Lbs	1.0
	Kgs	0.46
Capacity Of Cup	Liter	0.6NC
Standard Fluid Tip Size	mm	1.4
Optional Nozzle Size	mm	1.0,1.2,1.3,1.5,1.7,1.9,2.2



AS-0001D	H.V.L.P Spray Gun (Drop Forged Body)	
SPECIFICATIONS:		
TECHNICAL DATA		AS-0001D
Air Pressure	BAR	3
	PSI	43
Air Inlet		1/4"
Fluid Inlet		3/8"
Air Consumption	CFM	13.9
	L/MIN	390
Weight	LBS	2.2
	KGS	1.0
Capacity of Cup		1L
Type of Cup		ALUMINUM
Standard Fluid Tip Size (MM)		1.7
Length x Height (MM)		175 X 295
Feed Type		SUCTION
<ul style="list-style-type: none"> • Optional Nozzle Size : 1.0, 1.4, 1.5, 2.0, 2.3mm • Incl : Fluid Nozzle + Needle + Air Cap • Nozzle Needle : Stainless Steel 		



JA-6111	Deluxe Professional Gravity Feed Spray Gun	
SPECIFICATIONS:		
TECHNICAL DATA		JA-6111
Air Pressure	BAR	3.5-5
	PSI	50-70
Air Inlet		1/4"
Fluid Inlet		M16 X 1.5P
Air Consumption	CFM	14
	L/MIN	396
Weight	LBS	1.54
	KGS	0.7
Capacity of Cup		0.6L
Type of Cup		NYLON
Standard Fluid Tip Size (MM)		1.4
Length x Height (MM)		170 X 325
Feed Type		GRAVITY
<ul style="list-style-type: none"> • Optional Nozzle Size : 1.0, 1.2, 1.3, 1.5, 1.7, 2.0, 2.3, 2.5, 3.0mm • Incl : Fluid Nozzle + Needle + Air Cap • Standard Nozzle : Steel • Optional Nozzle : Stainless Steel • Optional Cup : 0.6L, 1.0L Aluminum Cup 		



AS-0001A	H.V.L.P Spray Gun	
SPECIFICATIONS:		
TECHNICAL DATA		AS-0001A
Air Pressure	BAR	3
	PSI	43
Air Inlet		1/4"
Fluid Inlet		3/8"
Air Consumption	CFM	14
	L/MIN	396
Weight	LBS	2.2
	KGS	1.0
Capacity of Cup		1L
Type of Cup		ALUMINUM
Standard Fluid Tip Size (MM)		1.7
Length x Height (MM)		175 X 295
Feed Type		SUCTION
<ul style="list-style-type: none"> • Optional Nozzle Size : 1.0, 1.2, 1.4, 2.0, 2.3, 2.5mm • Incl : Fluid Nozzle + Needle + Air Cap • Nozzle Needle : Stainless Steel 		



JA-6111K	Deluxe Professional Gravity Feed Spray Gun Kit	
<ul style="list-style-type: none"> • 1PC - JA-6111 Prof. Spray Gun • 1PC - 600 C. C. Nylon Cup • 1PC - 250 C. C. Nylon Cup • 2PCS - Needle • 2PCS - Air Nozzle Cap • 2PCS - 1.7MM & 2.0MM Fluid Nozzle • 1PC - Adapter • 3PCS - Stainless Strainer • 1SET - Tune Up Kit • 1SET - Spanner & Brush Kit 		



JA-507S	Professional Spray Gun	
SPECIFICATIONS:		
TECHNICAL DATA		JA-507S
Air Pressure	BAR	3-6
	PSI	43-90
Air Inlet		1/4"
Air Consumption	CFM	12-15
	L/MIN	337-421
Fluid Inlet		3/8"
Weight	LBS	2.3
	KGS	0.8
Capacity of Cup		1L
Type of Cup		ALUMINUM
Standard Fluid Tip Size (MM)		1.6
Feed Type		SUCTION
<ul style="list-style-type: none"> • Optional Nozzle Size : 1.0, 1.5, 1.8, 2.0, 2.5mm 		



JA-506G		Professional Spray Gun
TECHNICAL DATA		JA-506G
Air Pressure	BAR	3.5-5
	PSI	50-70
Air Inlet		1/4"
Fluid Inlet		1/4"
Air Consumption	CFM	12-15
	L/MIN	337-421
Capacity of Cup		0.4L
Type of Cup		STAINLESS STEEL
Standard Fluid Tip Size		1.4MM
Weight	LBS	2.3
	KGS	0.8
Feed Type		GRAVITY

• Optional Nozzle Sizes : 1.1, 1.8, 2.0mm



JA-23S		Professional Spray Gun (Suction Type)
TECHNICAL DATA		JA-23S
Air Pressure	BAR	3.9 - 4.9
	PSI	56 - 71
Air Inlet		1/4"
Fluid Inlet		1/4"
Air Consumption	CFM	14
	L/MIN	396
Weight	LBS	0.66
	KGS	0.3
Capacity of Cup		0.6 L
Standard Fluid Tip Size (MM)		1.4

• Optional Nozzle Size : 0.8, 1.1, 1.3, 1.5,1.8, 2.0mm



ACC-608

AIR REGULATOR
CAPACITY 0-150 PSI
(0 -10 BAR) FOR
JA-HVLP-40
JA-HVLP-40W



ACC-609

AIR REGULATOR
CAPACITY 0-150 PSI
(0 -10 BAR)



JA-3808A

OIL/WATER SEPARATOR
MATERIAL :
ACETATE FOR ALL
MODEL
SPRAY GUN



JAZ-0042

1/4" UNIVERSAL SWIVEL
AIR INLET JOINT



AS-0059A

21PCS
PROFESSIONAL
PAINT GUN
MAINTENANCE KIT

Contents/Special Features :
1SET-Precision needle Set (5pcs) & Alum. Holder-Cleans clogged air cap orifices
1PC-1/2" Body Cavity Brush- Cleans body cavities and air passages
1PC-Paint Gun Lube 1/2oz Lubes needles and tightens packing
1PC-Brass Power Pick-UP tube
Brush-Put on drill for clogged pick-up tubes.
1SET-Nylon Bristle Parts Brush (3pcs) & Alum. Holder-Cleans outside after each use.
5PC-Miniature brush Set-Cleans air horns and small orifices inside air caps & fluid nozzles.
3PC-Brush-Cleans large holes in HVLP air caps & fluid nozzles.

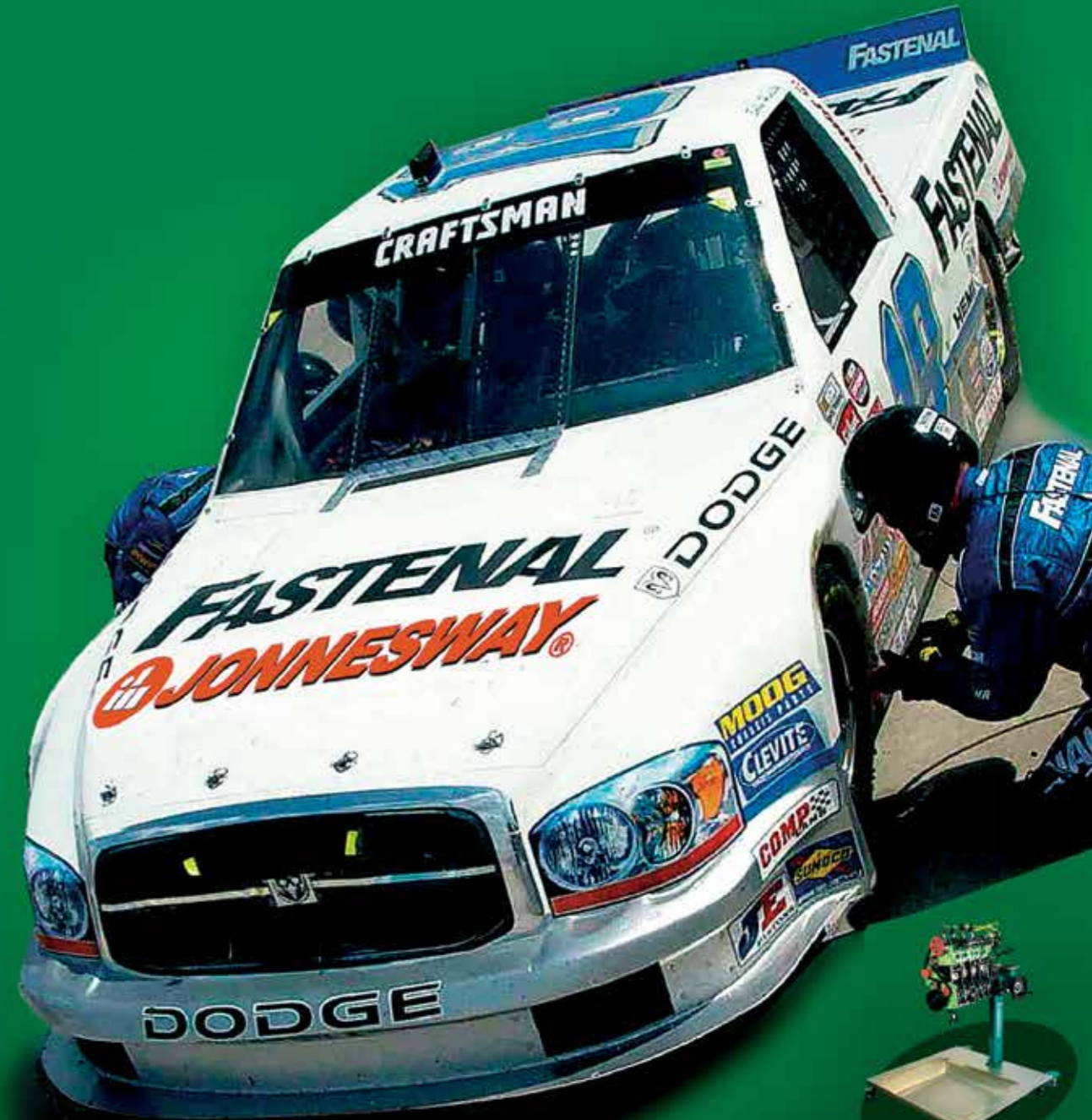

AUTOMOTIVE TOOLS

- Body and Interior Tools
- Brake Service Tools
- Engine Tools
- General Repair Tools
- Tools for Axle Repairs Silent Blocks & Bushes
- Clutch Repair Tools & Transmission Tools
- Tools for Steering System & Springs and Shock Absorbers

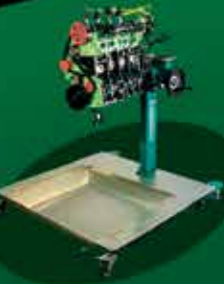



AE020002A AIR / HYDRAULIC PUMPS

ITEM NO.	AE020002A	
RATED PRESSURE	10,000 psi	
USABLE OIL CAPACITY	50 Cu. In.	
OUTPUT FLOW RATE (Cu. In. / Per Min.)	Unload	Load
	42.7	6.7
AIR PRESSURE RANGE	70 ~ 170 psi	
AIR CONSUMPTION	9 CFM	
WEIGHT	6.0 kgs	

Features:

- Air-power hydraulic pumps are designed for using with single-acting cylinders and tools, like Jackram's ram series.
- Rugged construction and most components are made of Aluminum.
- Alloy are built for long service life, easy operation and portability.
- Automatic overload relief valve setting at 10,000 psi protects components in hydraulic system and work safety regardless of air pressure.
- New inlet & outlet design features low exhaust air volume, no-noise effect and can be operated in all directions.
- Oil capacity can be modified according to your specific application.

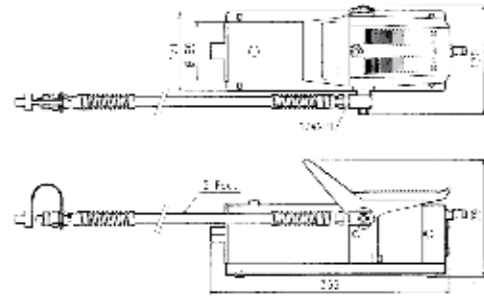

AE030002 TWO-SPEED HAND PUMPS

ITEM NO.	PRESSURE RATING (bar) 1st/2nd STAGE	USABLE OIL CAPACITY (c.c.)	OIL VOLUME PER STROKE(c.c.) 1st/2nd STAGE	A (mm)	B (mm)	C (mm)	D (mm)	E (mm)	OIL PORT THREAD (F)	WEIGHT (kgs)
AE030002	13.8 / 700	350	13.0 / 2.8	343	310	66	146	142	3/8 NPT	5.9

- JONNESWAY heavy duty hand pumps are featured with their forged construction.
- Dropping forged base and rugged welded construction prevents collision and deformation efficiently.
- Professional choice for a wide range of industrial applications.
- Both single and two-speed models are available.
- Internal overload valve prevents pump from being used beyond its rated capacity.
- Two-speed pumps provide fast pumping to meet the loading with the cylinder unloaded.
- External adjustable relief valve with anti-losing mechanism design.
- Carrying handles for easy portability.

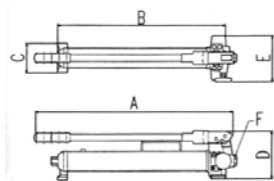

AE080004 TELESCOPIC TRANSMISSION JACKS
CAPACITY : 800 kgs

- For use with transmissions and transaxles of passenger cars and light trucks.
- Foot-operated pump for maximum lift with minimum effort and fast contact with load.
- Fully adjustable universal saddle with adjustable corner brackets and safety chain for optimum alignment of transmission bolt patterns.
- Safety overload system protects jack from being used beyond its rated capacity.
- N.W. 68kgs G.W. 71kgs CUFT 3.4'

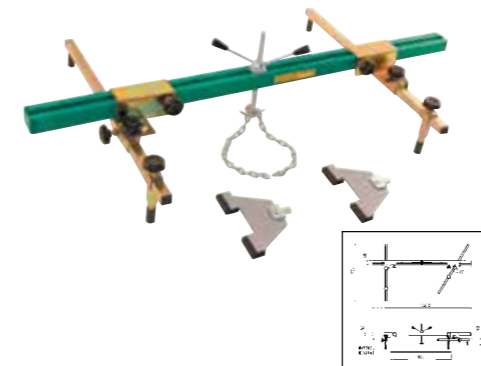

AE170006 UNIVERSAL TRANSVERSE ENGINE SUPPORTS

Features :

- Special new design for 4 fixing point to be a bridge to support the engine.
- Especially using one the car that without inner fender.
- Adjustable in height and width to bridge various vehicle fender walls and securely hold engine in place.
- With rubber in the 4 fixing point to prevent slip or damage the vehicle.
- AE170006 equipped with two feet to use on the car with inner fender.
- N.W. 38 kg G.W. 40 kg CUFT. 2.5, 2 pcs / carton

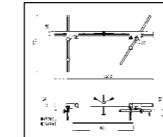

AE300165 80L WASTE OIL DRAINER (MANUAL VALVE)

ITEM NO.	AE300165
DIMENSION	470 x 560 x 1140~1580 m/m
CAPACITY	80 L
WEIGHT	36 kgs
POWER	Compressed Air 100-120 psi
OIL DRAINING	Air Pressure

- Waste oil mobile reservoirs to be used for motor and gear oil collection.
- Drainers can be set under vehicle lifts or inside lubrication pit.
- Large handle for easy maneuverability.
- Two brake wheels (φ3") and two casters (φ3")
- Extra large drain bowl / Adjustable collecting bowl / For the convenient and safe collection.



AE300051 PRESSURE BRAKE BLEEDER

ITEM NO.	AE300051
DIMENSION	350 x 275 x 450 m/m
CAPACITY	5 L
WEIGHT	9.6 kgs

- Air operated pressure brake bleeder.
- Suitable for clutch bleed as well as brake bleed.
- 5 Litre capacity tank.
- Complete with AE300051 master cylinder adaptor kit.



AE300064 17 PC RADIATOR PRESSURE TESTER

- Including: adaptors, hand pump, airline regulator assembly, and instruction manual
- Different adaptors can be applied to most of car brands, such as AUDI, BMW, CITROEN, FIAT, FORD, VAUXHALL, OPEL, PEUGEOT, VOLVO, and VOLKSWAGEN
- With 3 pcs of universal adaptors, which can be apply to any vehicles with the same size radiator cap
- For quick detection of radiator or hose system leakage
- Special designed storage case shows storage place for each adaptor, and provide easy accessory management



AE300095 14PCS RADIATOR PRESSURE TEST

- Detecting leak of car radiator or tube system precisely, rapidly.
- Offer professional service quality, and easy operation.
- Conform every kind of car radiator's opening diameter & high quality of full-set accessories.
- The main body is Aluminum Alloy material.



AE300161 COOLING SYSTEM & RADIATOR CAP PRESSURE TESTER

Contents	Applications
System Testing Adapter NO.1	GM 4 cylinder (BUICK, CHEVROLET, OLDSMOBILE, PONTIAC, CADILLAC)
System Testing Adapter NO.2	Truck
System Testing Adapter NO.3	MERCEDES-BENZ, FORD, CHRYSLER, GM, JEEP, TRUCK, PEUGEOT.
System Testing Adapter NO.4	ACURA, DODGE, EAGLE, GEO, HONDA, ISUZU, LEXUS, MAZDA, MITSUBISHI, SUZUKI, TOYOTA, INFINITI, NISSAN, GM (NOVA, SPECTRUM, SPRINT), PEUGEOT, FORD, CHRYSLER.
System Testing Adapter NO.5	TOYOTA, HONDA, MITSUBISHI, SUZUKI, LEXUS, CHRYSLER, ACURA, DODGE, GEO.
"2.3" Cap adapter	Testing the pressure cap
"4.5" Cap adapter	Testing the pressure cap
Cooling System pump	with pressure Gauge



AE300103 16L WASTE OIL STORAGE

- Capacity : 16 L / Size : 600x450x180 mm/ Weight : 1.05 kgs

AE300061 OIL EXTRACTOR
CAPACITY : 6.5 LITERS

- For DIY or professional use.
- Simple and easy to operate.
- Suitable for engine oil, gear oil, transmission and brake fluid water.



AE300178 COMBO FLUID EXTRACTOR

- Adopt durable polyethylene material.
- Uses both manual or air for operation.
- Venturi system design to provide excellent performance.
- Oil depletion : manual or air.
- Dimension : 265x315x650m/m.
- Capacity : 9.5 litre.
- Maintenance free.
- Suction tubes included (4pcs).
(1) 7 mm steel oil suction tube.
(2) 6 mm oil suction tube.
(3) 6mm steel oil suction tube
(4) 10 mm gear oil tube.

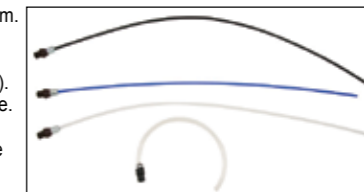

AE300177 VACUUM BRAKE FLUID BLEEDER

- Vacuum brake bleeder.
- 6 litre capacity.
- Uses standard workshop air supply.
- Remove fluid via nipples to allow bleeding or entire fluid replacement.
- Material : PE.



TRANSMISSION FILLING SYSTEM INCLUDE



AE300176 TRANSMISSION FILLING SYSTEM
AE300176-A OPTIONAL ADAPTORS

- Dimension: 260X370X59 5M/M
- Capacity: 7.5L
- Weigh: 3.44KG

AE300176-A

- **AE300176-A**
- OPTIONAL ADAPTORS FOR
(1) Mercedes 722.9
(2) VW/AUDI DSG
(3) VW/AUDI CVT



AE300187 PNEUMATIC OIL & LIQUID DISPENSER (6000C.C)

- Provide with the safety valve helps the pre-setting pressure (43psi(3kg/cm²)) relief automatically.
- Provide with pressure gauge makes read and control the air pressure in the tank easier.

Air inlet	1/4"
Avg. Air cons	2 CFM
Temperature rang	-19.4°C ~ 60°C (-3°F ~ 140°F)
Max. Capacity	6000 c.c.



AE300200 PNEUMATIC BRAKE OIL CHANGER

Features:

- Easy to operate & carry
- Automatic stop function
- Time saving
- Simple & neat
- Open & close vale to control extraction

Size	11" X 8"
Includes	Bleeding Tube Φ 5.8mm OD X 1.5m / Refill pot 1liter
Capacity	2L
Max Temperature	100°C
Working pressure	90psi
Air Inlet Size	1/4" NPT
Weight	1.8kgs

Application:

- Drain brake and power steering fluid from reservoirs.
- Works great on cars, motorcycle, truck etc...
- Use with brake bleeding
- Accessory kit to bleed brakes lines.



AE300072 AIR OPERATED GREASE PUMP

- Can have capacity 12-22kg original bucket grease or in bulk 30L grease suit for 00#-2# grease.
- Can have capacity 12-22kg original bucket grease or grease suit for 00#-2# grease.

ITEM NO.	CAPACITY	AIR INLET PRESSURE	PRESSURE RATIO	FLUID OUTPUT PRESS	DELIVER RATE	HOSE LENGTH
AE300072	30L	4-9 kg/cm ²	45 : 1	180-405 kg/cm ²	30c.c./sec	10 ft



AE300213 BRAKE BLEEDER

- Capacity: 1L
- Material of blow gun: P.O.M.
- Air consumption: 160L/MIN (5.6 CFM)
- Blow gun air inlet: 1/4"
- Santoprene hose: 1M
- Working pressure: 5-8 BAR (72-116 PSI)



AE300197 MULTI-FUNCTIONAL BRAKE BLEEDER

- Manual Operation
- Capacity: 3L
- Size: 170mmx 285mm
- Accessory: Universal Adapter Tube Ø7.5mm x 1M
- Packaged weight: 1.5kgs



AE300195 UTILITY IN & OUT FLUID SYRINGE

- Manual Operation
- Capacity: 350ml
- Size: 381 x 75 x 75mm
- Accessory: Oil resistant tube
 - OD Ø9.8mm x L300mm
 - OD Ø11 mm x L300mm
 - Tube plug
- Net weight: 0.48kg
- Product Features:
 1. It can be used for any non-corrosive lubricants
 2. The flow rate is adjustable
 3. Connect different tubes for different functions



AE310001 6 WAYS MULTI PURPOSE HYDRAULIC GEAR PULLER

1pc Hydraulic Ram (SCM415 φ 37.7MM x L160 x 16t)
1pc Combination Cross Head (Carbon Steel)
3pcs Combination Leg (SCM415 Drop Forged Hardened 42° ~ 45°)
6pc Steel Plate
1pc Extension Rod (1" x 1-1/4" Carbon Steel)
1pc Extension Rod (1" x 2" Carbon Steel)
6pcs Screw Nut & Washer
Packing : 5sets/CTN/24/25/1.3"



AE310004 HYDRAULIC SEPARATOR PULLER SET

1pc Hydraulic Ram (SCM415 φ 37.7mm x L160 x 16t)
1set bearing separator & bolts (SCM415 Drop forged hardened 42° ~45° ,capacity 6") (Bolt 5/8"x11ncxL216mm φ 16mm SCM415)
2pcs main rod (hex bar21mmxL7"x5/8"11nc carbon steel)
2pcs extension rod (hex bar 21mmxL7"x5/8" 11nc) carbon steel
1pc beam, carbon steel
1pc adaptor, carbon steel
1set/metal box/ctn/0.8'/24/25kg



AE310005 PRESSURE SCREW SEPARATOR PULLER SET

1pc beam, carbon steel
1pc central bolt φ 18.65mmxL11.5"x10t
1pc nut, carbon steel
1set bearing separator & bolts (SCM415 drop forged hardened 42° ~45° , capacity 75-105mm)
2pcs main rod (8"x1.75p carbon steel)
2pcs extension rod (8"x1.75p, carbon steel)
Packing : 4sets/metal box/ctn/1'/30/31kg



AE310006 TWO SETS BEARING SEPARATOR ASSEMBLY

1set bearing separator & bolts
1set bearing separator & bolts
4pc main rod (hex bar 17mmx7/8"xL127mmx16t)
1pc beam, carbon steel
1pc center bolt (9/16"XL175X10t/inch carbon steel)
Packing : 5 boxes/ctn/1.2'/21/22kg



AE310008 INTERNAL & EXTERNAL PULLER SET

AE310008-1 T-Bar (S45C Carbon Steel) 5/8 x 18T x L425mm
AE310008-2 Hammer (S45C Carbon Steel) 53mmxL100mm 1.2kgs
AE310008-3 Nut
AE310008-4 Centre Screw
AE310008-5 Washer
AE310008-6 Internal Puller Capacity : 15mm-30mm
AE310008-7 Internal Puller Capacity : 30mm-80mm
AE310008-8 External Puller Capacity : 15mm-80mm
AE310008-9 Adapter 31x10
AE310008-10 Adapter 18x6.5
AE310008-11 Triple Head
AE310008-12 Screw
Packing : 1 Set/Blow Case, 4sets/ctn./18/19/1.8'

- Size : Small of internal puller 15mm~30mm
Large of internal puller 30mm~80mm
External puller 15mm~80mm
- Locking the nut to open 3-jaws and clip the bearing.
And then use the slide hammer to pull out the bearing.

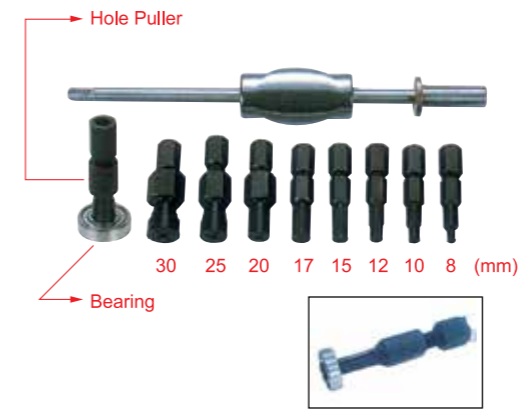

AE310082 BEARING HOLE PULLER KIT

- Open clamps by turning handle clockwise to snug against the bearing for pulling out evenly without damage the parts.



AE310018 WASHER SLIDE HAMMER SET

- Pull with slide hammer with washer in the body.



AE310010 SLIDE HAMMER

1pc T Bar (Carbon Steel)
1pc Hammer (5Lbs. Cast Iron)
1pc Axle Puller (Drop Forged Carbon Steel)
1pc Grip Wrench Adapter
1pc Nut
1pc Two Jaw Head
1pc Three Jaw Head
3pc Screw & Nut
1pc Attachment
3pc Jaw (Drop Forged Carbon Steel)
1pc Tapping Screw
1pc Hook
Packing : 1 metal box, 2 sets/ctn/14/15/1'

- Increased the coverage with the two axle pullers.
- Works together with other tools is more easy.
- Included 3-Jaw puller and many types of joints.



AE310076 AE310077 UNIVERSAL BALL JOINT PULLER

- Features:**
- Special steel for removing the ball pivots on steering arms, steering tie rocks, steering knuckles, etc.
 - AE310076 - JAWS OPEN : 17mm
 - AE310077 - JAWS OPEN : 20mm



AE310013 UNIVERSAL WHEEL HUB PULLER

- SIZE:**
- 90~140mm/3-1/2"~5-1/2"
 - 130~180mm/5-1/8"~7-1/16"



AE310012 BLIND HOLE BEARING PULLER

- One slide hammer assemble & 4 clamp.
- Attachments for 3/8" to 1/2"(10-14mm), 9/16" to 11/16" (15-19mm), 5/8" to 1" (18-25mm) & 1" to 1-1/4"(25-32mm) I.D. bearings' pulling.
- Open clamps by turning handle clockwise to snug against the bearing for pulling out evenly without damage the parts.



AE310015N FRONT WHEEL DRIVE UNIVERSAL FRONT HUB & BEARING INSTALLER

- M12 X P1.5 X 3
 - M14 X P1.5 X 3
- UNIVERSAL FRONT HUB & BEARING INSTALLER (PULLER)



AE310022 PITMAN ARM PULLER

Pitman Arm Puller (SCM 415) Hardened 42° 43°
Centre Bolt : (S45C Carbon Steel) Hardened 42° 43°
Packing : Tray/Skin Packed
5Sets/Inner
20Sets/18/19/1'

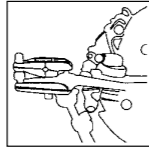

AE310023 BALL JOINT PULLER

SCM-4140 Hardened 45°
Bolt : SCM-4140 Hardened 45°
Centre Connector : SCM-4140 Hardened 45°
Packing : Inner Box
20Sets/21/22/1'



AE310110 BALL JOINT EXTRACTOR

SIZE : 23 MM

AE310111 BALL JOINT EXTRACTOR

SIZE : 29 MM



50mm

AE310024 BEARING SEPARATOR

- SCM415 Hardened 42~ 45°
- Capacity : 1-1/4"-2-1/4" (30mmx50mm)
- Boltφ 9.5mmxL125mmx3/8"x24t
- Packing : 20set/ctn/20/21kg/0.5'



75mm

AE310025 BEARING SEPARATOR

- SCM415 Hardened 42~ 45°
- Capacity : 2-1/4"-3-1/2" (50mmx75mm)
- Boltφ 12.7mmxL135mmx1/2"x20t
- Packing : 12set/ctn/18/19kg/0.6'



100mm

AE310026 BEARING SEPARATOR

- SCM415 Hardened 42~ 45°
- Capacity 3"-4-1/2" (75mmx105mm)
- Boltφ 16mmxL165mmx5/8"x18t
- Packing : 10set/ctn/20/21kg/0.7'



150mm

AE310027 BEARING SEPARATOR

- SCM415 Hardened 42~ 45°
- Capacity 4"-6" (105mmx150mm)
- Boltφ 19mmxL260mmx3/4"x16t
- Packing : 6set/ctn/30/31kg/1'



AE310205 2TON GEAR PULLER

AE310206 5TON GEAR PULLER

AE310207 7TON GEAR PULLER

- Unique design patented for windy industrial using.
- Changeable jaws for 2&3 operation.
- Adjustable angle fixed jaws for easily working.

1. The product made by high quality material of CR-MO, SK5 within high torque strength for professional using.
2. Adjustable angle fixed jaws have convenience working easily.
3. Quick release to save time and easy operation for effective working.
4. Easy simple action to change the jaws be inside or outside working
5. Changeable jaws for 2 or 3 jaws operation.

ITEM NO.	RANGE	WEIGHT
AE310205	2"~4"	0.42kg
AE310206	4"~7"	1.4kg
AE310207	5"~8"	2.9kg



AE310149 4 WAY BALL JOINT REMOVER TOOL

- Heat Treated drop forged steel body & bolt for long rought usage.
- Spread ball joints easily where space prevents use of direct action method.
- Total Length:165mm
- Opening Angle:24~45mm
- Jaw Opening:20mm
- Body Material:SCM440



AE310151 GEAR PULLER (THIN JAWS)

- Special puller with ultra thin jaws for removal of crankshaft timing gear.
- Depth:100 mm
- Outside:40-90 mm



AE310150 PULLER FOR RIBBED DRIVE PULLEYS

- Clamps onto any ribbed pulley
- Suitable for use on crankshafts, alternators, air conditioning units and water pumps.

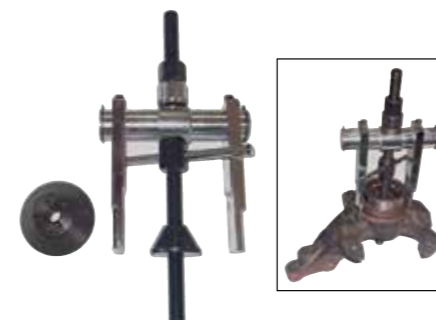

AE310117 AXLE BEARINGS EXTRACTOR / INSTALLER

- Removal and replacement tool for wheel axle bearings.
- Applicable : BENZ, BMW, TOYOTA, FORD, MITSUBISHI...etc.
- NW : 4.9 kgs GW : 5.1 kgs



AE310095 4 TON HYDRAULIC PULLER

- Features:**
- Special package model includes 2/3 jaws puller and 2 jaws puller with attachment in one set.
 - Ideal impact package with light PE case for carrying.
 - One complete set with two kinds of puller for user's convenience always.

ITEM NO.	CAPACITY	REACH (mm)		SPREAD (mm)		STROKE (mm)	PUMP TIP (mm)			JAW TIP (mm)				WEIGHT (kg)
		A	B	C	D		E	F	G	A	B	C	I	
AE310095	4 Ton	185/250	70	75/55	255/110	60	42	22	84	11	6	22	32	4.5/8.5



AE310029-33 2-JAWS CR-V GEAR PULLER

ITEM NO.	SIZE	RANGE (MM)	CAPACITY (Ton)
AE310029	3"	40-76	1.5
AE310030	4"	50-102	3.5
AE310031	6"	60-152	5
AE310032	8"	80-203	8
AE310033	12"	120-306	13



AE310034-38 3-JAWS CR-V GEAR PULLER

ITEM NO.	SIZE	RANGE (MM)	CAPACITY (Ton)
AE310034	3"	40-76	2
AE310035	4"	50-102	5
AE310036	6"	60-152	7
AE310037	8"	80-203	12
AE310038	12"	120-305	18



AE310048-49 ARMATURE BEARING PULLER

ITEM NO.	DISASSEMBLY OUTWHEEL CAPACITY
AE310048	19-35 mm
AE310049	24-55 mm

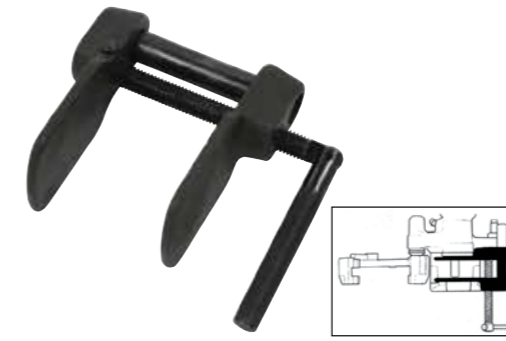

AE310072 DISC BRAKE PISTON SPREADER



AE310053 9 PIECES HARMONIC BALANCE PULLER

- Yoke 1 Piece (Ductile)
- Bolt 1 Piece (φ 15.5mmxL140mmx11/16inch Carbon Steel)
- Adapter : 1Piece
- Screw
- 3 Pieces 3/8" x 24 UNF x 3"
- 3 Pieces 3/8" x 16 UNC x 3"
- Packing : 1Set/Blow Case
- 16Sets/ctn/28/29/1.5'



AE320023~24 HEAVY DUTY COIL SPRING COMPRESSOR

- Drop forged by fully CR-MO and heat treated ensure obtain professional job.
- The tool is designed for use in limited space under wheel arch.
- Jaw design is fitting to wrap coil claws for safety.

ITEM NO.	MAXIMUM JAW OPENING
AE320023	270mm
AE320024	370mm



AE320034 MACPHERSON SPRING DUMPER EXTRACTOR / INSTALLER(CHANGABLE)

- Spring compressors are multi-application tools specifically developed for modern McPherson suspensions, using a range of 3 sets of interchangeable mono block forks.
- Application : BMW, TOYOTA, FORD, MITSUBISHI, VW, AUDI, SAAB NISSAN, HONDA, ACCORD, SUBARU, VOLVO, OPEL, PORSCHE.



AR020042 SMART CAR BATTERY TESTER
12V 10 - 80 AH

TECHNICAL DATA	12Vdc Battery System
INPUT VOLTAGE SYSTEM	9- 16 Vdc
POWER DISSIPATION	50 - 150 mA
OUTPUT INTERFACE (OPTION)	Photo Couple Output
OUTPUT DISPLAY MODEL	LCD Display
AUDIO ALARM	2Khz Buzzer
DIMENSION, (L*W*H)	87*38*22.4 mm
OPERATION ENVIRONMENT	-20 °C ~ 70 ° C < 80%RH
WEIGHT	200 gm

AR020060 2000A DCA/ACA CLAMP METER + DMM
2+1 TRUE RMS



- Features:
- 2 in 1, 2000 A clamp meter +Digital multimeter.
 - Meet IEC 1010 CATIII 1000V safety requirement.
 - True rms reading for ACV & ACA measurement.
 - 4000 counts, Auto range , multi-functions for ACA , DCA , ACV, DCV , Ohms , Capacitance , Frequency (Hz), Diode , Duty cycle and continuity check.
 - LSI circuit provides high reliability and durability.
 - Wide ranges (2000A , 400 A) clamp on current measurement both for ACA & DCA.
 - 4 ranges (400 uA , 4000 uA , 40mA , 400 mA) direct current input measurement both for ACA & DCA.
 - Zero adjustment : DCA : Push bottom adjustment . Other ranges : Automatic adjustment.
 - Overload protection circuit is provided for all ranges.
 - 240uA-240mA small direct current input.
 - 65mm measuring conductor size with unique two way open clamp.
 - Data hold, Relative key, Back light.
 - Compact & heavy duty ABS, panel water resistance and fireproof plastic case.

AR020061 TRUE RMS MULTIMETER



- Heavy duty CAT III-1000V category, meet IEC 1010 CAT III 1000 V safety requirement.
- 4000 counts, Auto range with manual range selection.
- Large LCD(65 mm x 48 mm)display with measurement unit with bar graph indicator, digit height 23 mm.
- True RMS ACV:400.0 mV /4 V/40 V/400 V/1000 V;continuity buzzer;ACA&DCA (10 A/400 mA/40 mA/4000 uA/400 uA);diode;DCV(400.0 mV /4 V/40 V/400 V/ 1000 V);Duty cycle; Capacitance(40 nF/400 nF/4 uF/40 uF/100 Uf);ohms (400/4 K/40 K/400 K/4 M/40 M ohm); Hz(4 Hz/40 Hz/400 Hz/4 KHz/40 KHz/ 400 KHz/4 MHz).
- Data hold, Relative, range hold.
- High input impedance for mV range.
- 10 Amp. current with fuse protection.



AR020016 DIGITAL AUTOMOTIVE ANALYZER & MULTI METER

- Function : RPM, Dwell, Volts DC, Volts AC, Amps DC, Resistance, Duty Cycle, Temperature, Pulse Width, Frequency, Diode test, Audible Continuity, Battery Test



AR020017 UNIQUE COMPRESSION TESTER KIT

- Full 2-1/2" dial
- Color-coded quadruple calibrations with 0-300 psi, 21kg/cm², 21 Bar and 2100 kpa
- A 6" heavy-duty stem and 13" durable flexible hose included tune-up Tools
- The accurate compression, vacuum and pressure testers provide a handy work and high performance on engines and fuel systems.



AR020018 FLEX-DRIVE COMPRESSION TESTER

- Full 2-1/2" dial
- Color-coded quadruple calibrations with 0-300 psi, 21kg/cm², 21 Bar and 2100 kpa
- A long heavy-duty flexible hose with a 14mm/18mm adapter convenient pressure-holding, side release valve



AR020019 PROFESSIONAL VACUUM & FUEL PUMP TESTER

- Tests on worn or faulty parts in fuel pumps, vacuum systems and related lines
- Large 3-1/2" dial with color-coded scales
- A long, flexible, heavy duty rubber hose and manifold adapter included.



AR030031 ELECTRIC CIRCUIT TESTER

- Voltage: 6-24 dcv
- Wire length: 4,5mt
- 8A safety gear inside.
- The automatic power failure will start when voltage is over the limit.
- This tool also can test positive and negative voltage.
- Tests continuity in switches, relays, diodes & fuses, and wiring harnesses.
- Polarity test cables and sockets.
- Find short circuits and bad earths.fast



AR030004 "LIFETIME" HEAVY DUTY CIRCUIT TESTER

- The best quality electrical tester available for checking 6 and 12 volt systems. Made to last a lifetime
- Has heavy duty ground clip and insulator. 5' of tough flexible rubber wire is retained in spring supported strain relief designed to withstand the most rugged use. Bulb is easily replaced.



AR030007 CAR BATTERY & ALTERNATOR CHECKER

- LED lights indicate car battery condition (engine stop) or output of alternator (engine running)
- Lights show poor, fair or good condition.
- Magnetic backboard keeps your hands free for checking.



AR030013 BATTERY HYDROMETER

- Tests the battery in seconds.
- Color-coded float for easy reading.



AR030024 ASSORTMENT OF R-12 & R-134a O-RING KIT

- Contents :
 5.28 x 1.78 x 20pcs ; 6.07 x 1.78 x 20pcs ; 6.8 x 1.9 x 20pcs ;
 7.65 x 1.78 x 20pcs ; 7.8 x 1.9 x 20pcs ; 8 x 2 x 20pcs ;
 8.8 x 1.9 x 20pcs ; 9.25 x 1.78 x 5pcs ; 9.8 x 1.9 x 15pcs ;
 10.82 x 1.78 x 15pcs ; 11 x 2 x 10pcs ; 14 x 2 x 10pcs ;
 12 x 2 x 15pcs ; 13 x 2 x 10pcs ; 13.8 x 1.9 x 10pcs ;
 13.95 x 2.62 x 10pcs ; 14 x 2 x 10pcs ; 17 x 2 x 10pcs ;
 17.17 x 1.78 x 10pcs
- Applicable : R-12/R-134
- Total : 270 pcs.



AR030018 AUTOMOTIVE BLADE FUSE KIT

- Size : 5A, 7.5A, 10A, 15A, 20A, 25A, 30A
- Puller x 1
- Total : 106pcs



AR040018 METAL CASE BATTERY BRUSH (C.E.D. COATING)

- Designed for cleaning the battery terminals.
- You can use on both sides.



AR060001 HOSE CLAMP PLIERS

- A new design plier for all kinds of hose clamp.
- Special design for narrow space.
- Tips and jaws swivel through 360 degrees.



AR060021 FLEXIBLE HOSE CLAMP

- For replacement of fuel, oil and water hose.
- Hose clamp with flexible 630mm wire.
- Convenient for working hidden areas and long distance.



AR060015 7PCS DISCONNECT SET

- Includes six tools for disconnecting spring couplings on Ford, GM, and Chrysler air conditioning lines. Also works on fuel lines and can be used as push lock connectors on radiator and transmission lines.
- 1/4", 5/16", 3/8", 1/2", 5/8", 3/4", 7/8"



AR060017 RUBBER SPARK PLUG REMOVER AND INSTALLER

- Flexible shaft permits access from many angles.
- Easily insert & remove hard-to-reach spark plugs with the flexible shaft tool.
- Soft-stepped tip firmly grips terminal and porcelain.
- Special design helps you avoid hot engine burns.



AR060032 A/C SPRING LOCKING COUPLING TOOL

- Release spring lock connector on air conditioning line. For separating spring lock air conditioning refrigerant pressure lines on 1981 current FORD cars and pick-ups with spring lock connection. There are four sizes : 3/8"(red), 1/2"(blue-black), 5/8"(black), 3/4"(white).
- Fuel line disconnects tool set.
- All the disconnect tools you need to work with quick connect fuel lines on FORD, CHRYSLER, and GM, and on the spring lock fuel line couplings on FORD's popular port fuel injection system.
- Works on 5/16", 3/8" and 1/2" fuel lines.
 3/8"(yellow) and 1/2"(green) : Releases spring lock connectors on fuel line.
 5/16"(gray) and 3/8"(blue) : Releases quick connect fitting on fuel line.
 Transmission cooler line and fuel line quick.
Disconnect Tool
 Removes push lock connectors found at both the radiator and transmission



AR060035 FUEL & TRANSMISSION LINE DISCONNECT SET

- Instructions :
1. Choose the appropriate disconnect tool for the desired job. Make sure that you have chosen the tool for the correct pressure line diameter.
 2. Position the tool as per the illustration.
 3. Apply slight pressure toward the connector fitting pressing strong enough to depress the "connector fingers" that maintain the connection.
 4. Remove the pressure line
 5. To replace : place the pressure line fitting onto the desired fitting destination and apply pressure. A click sound signifies the re-connection of the pressure line.



AI010008 WRINKLE-BAND PISTON RING COMPRESSOR

- Adjustable band expands from 3" to 5" (76mm-127mm).



AI010030 ADJUSTABLE UNIVERSAL CAMSHAFT PULLEY HOLDING TOOL

- For use on all kinds of engines.
- Designed with grooved pins which are designed hold the camshaft pulley stationary while loosening and tightening the center shaft bolt.
- While useful on most Asian overhead cam engines, it's most needed on transverse mounted V6 engines such as the VG30 used in Nissan maxima, as well as, the 3VZFE and 1MZFE engines used in TOYOTA CAMRYS.
- The rear pulleys on these models are in very close proximity to the shock tower making removal and replacement difficult without this locking device.
- Application : BENZ, BMW, FORD, MITSUBISHI, HONDA, VW, AUDI, NISSAN, VOLVO, TOYOTA, ETC.
- Adjustable Distance : P.C.D 21mm~100mm



AI010012A VALVE COLLET REPLACER (FOR 8V / 16V / 24V ENGINE)

- Replaces tapered split collets on recessed valve springs quickly and easily.
- The special spring loaded unit places collets in position on recessed heads instantly.
- Includes magnet to retrieve collets.
- One valve spring is compressed, one end of the tool positions collets and magnet end picks up loose collets.

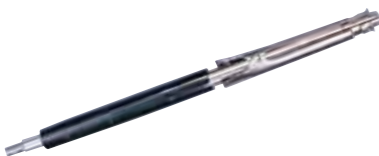

AI010017 STRAIGHT EDGE

- Great stability with 5/8" width, 1-3/8" height and 20-1/2" length.
- Convenient hanging hole and edge protector.
- Use with feeler gauges to check for distortion in engine blocks, cylinder heads and flywheels.



AI010040 UNIVERSAL TWIN/4 CAM LOCK (GAS & DIESEL ENGINES)

- Designed to lock TWIN CAMSHAFTS to timing marks during timing belt replacement. Fit onto sprockets and extends to lock in to sprocket teeth. Adjustable arms.
- Fit various diameters and tooth pitch. Also suitable for locking between cam and diesel INJ.

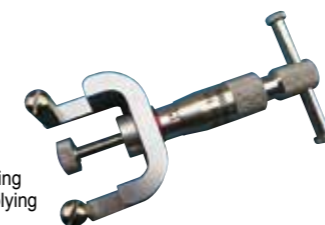
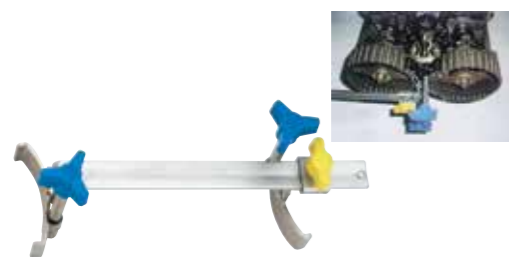

U.S.A. pat. Applying
TAIWAN pat. Applying

AI010079 UNIVERSAL ENGINE BELT TENSION TESTER

- This tool can be used to confirm tension on the engine belt of cars.
- Simple to check the belt for proper tension.
- Suitable for all common types of engine belt. Including timing · ribbed · tooth and V-belt.

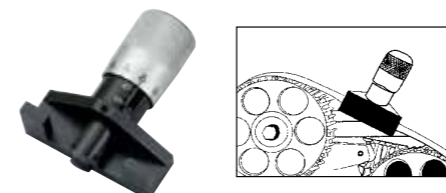

AI010063 BELT GAUGE

- It can be used to adjust the tension on the cam belt where the movement of timing belt is measured by load (NM).
- Suitable for use on cam belts various belt widths.
- Easy to use.
- Clear incremental marking with knurled knob for precise measurement.
- Dual scale allows reading from top or bottom of tool.

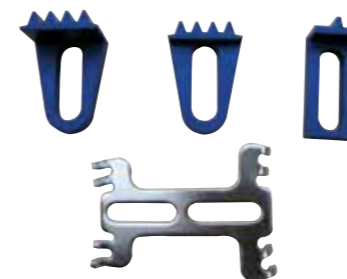

AI010042 FLYWHEEL HOLDING TOOL SET

- Designed to prevent the crankshaft from rotating when removing the crankshaft pulley for timing belt replacement.
- The pulley bolt has a high torque loading in which case the engine must be locked securely when releasing and tightening the bolt.
- Teeth-Like design allows the operator to engage the flywheel teeth and the tool is bolted to the transmission housing to prevent movement of the flywheel.
- Set supplied with 4 most popular tools.
- Ideal and essential for removing the crankshaft pulley when replacing the timing belt.



AI010041 PETROL ENGINE TWIN CAM LOCKING/SETTING TOOL AND FLYWHEEL HOLDING TOOL KIT

- The kit supplied with adequate tools to lock the camshafts on twin cam (multi-valve) engines in order to stop them rotating out of timed position when the timing belt is replaced and removed.
- It also provides different camshaft locking pins that can cover specific crankshaft and flywheel locking applications.
- Allows the service easier and reduce the risk of incorrect valve timing from taking place.
- Kit also supplied with two popular flywheel holding tools. They are ideal and essential for removing the crankshaft pulley when replacing the timing belt.
- Suitable for a range of vehicles including : HONDA, LAND ROVER, ROVER, VW, RENAULT, CITROEN, PEUGEOT, FIAT and VAUXHALL/OPEL.
- 19 pc. kit contents :
Camshaft locking tool x 10, Locking pins x 4
Setting and locking plate, Balancer pin,
TDC location pin and Flywheel holding tool x 2



AI010078 FAST CHECK WIRE-CLIP



- Easy,rapid and convenient measuring checking.
- It designed to check various electric wires.
- Contents:black and red clips.

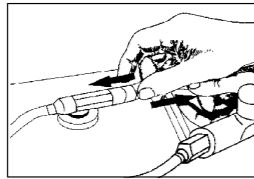

AI010067 6 PCS PLASTIC BRAKE HOSE DISCONNECTOR

- Use for one touch type connector.
- To release hose from connector pushing ratanor by release tool than pull hose by hand.
- Use for most of the truck and bus.
- Size including:6.8.10.12.15.16 m/m.



AI010062 COMPRESSION TESTER ADAPTOR (LONG REACH)

- Special design to extension the spark plug thread in the deep hole for easier testing.
- Length: 263mm, thread: 14mm.



AI010033 OXYGEN SENSOR WRENCH

- Put a slot in the side of this wrench to accommodate connectors on heated oxygen sensors, which usually won't fit in standard sensors wrenches. The extended and reinforced body removes the most stubborn sensors without rounding them off.
- Features 1/2 of the double square drive, 7/8" (22mm) hex.
- Flare nut for vacuum switch & oxygen sensor service on the computer-controlled engines.
- Applicable models : FORD, TOYOTA, NISSAN, BENZ, BMW and most of the European cars.



AI010104 UNIVERSAL ADJUSTABLE FUEL TANK LID REMOVER / INSTALL

- Jaw adjustable rang : 122~199 mm,suitable for different fustl tank lid
- Special jaws design to remove & install the tank closely
- Uses with Dr.3/8" wrench
- Applicable : BENZ \ BMW \ AUDI \ European cars...etc



AI010060 4PCS INJECTOR SOCKET SET

- 22mm (6pt), 22mm (12pt), 27mm (12pt), 28mm (12pt)
- For Use On: ALFA ROMEO, CHRYSLER, BMW, FORD,VW,MERCEDES, AUDI, OPEL,VAUXHALL,SEAT,VOLVO,ROVER ALSO ON VOLVO, MAN2.5TD & SCANIA HGVS.

DIAMETER	DESCRIPTION	LENGTH
22MM	INJECTOR SOCKET(6PT)	110MM
22MM	INJECTOR SOCKET(12PT)	75MM
27MM	INJECTOR SOCKET(12PT)	78MM
28MM	INJECTOR SOCKET(12PT)	78MM



AI010090A 22PCS 1/2" DR. ALTERNATOR INSERT BIT SOCKET SET

- 1pc- M10 Spline Bit Ssocket with 33T Nut: 110mm (L)
- 1pc- M10 Spline Bit Ssocket with 31T Nut: 98mm (L)
- 1pc- M10 Spline Bit,14mm Hex.Drive: 57mm (L)
- 1pc- M10 Spline Bit Socket: 110mm (L)
- 1pc- T50 Tx-Star Bit Socket with 33T Nut: 110mm (L)
- 2pc- 75mm (L), Spline Bit: M8, M10
- 2pc- 75mm (L), Tx-Star Bit: T40, T50
- 2pc- 75mm (L), Hexagon Bit: 8, 10mm
- 1pc-33Teeth Alternator Nut with 15mm Hex. Tip
- 1pc-33Teeth Alternator Nut with 17mm Hex. Tip
- 1pc-33Teeth Alternator Nut with 22mm Hex. Tip
- 1pc-17mm Hexagon Alternator Nut
- 1pc-22mm Hexagon Alternator Nut
- 1pc-28mm X 22mm Hexagon Alternator Nut
- 1pc-28mm X 21mm Hexagon Alternator Nut
- 1pc-28mm X 19mm Hexagon Alternator Nut
- 1pc-4 Points Alternator Nut with 17mm Hex. Tip
- 1pc-3 Points Alternator Nut with 38mm Hex. Tip
- 1pc-1/2" Square Drive X 10mm Hex. Bit Holder



AI020015 VALVE SPRING COMPRESSOR FOR GENERAL CAR FOR SMALL ENGINE

- Jaw opening Min : 2-5/16"
- Max : 4-3/4"
- Throat clearance : 6"



AI020016 VALVE SPRING COMPRESSOR FOR TOYOTA GENERAL CAR

- Compress valves on small overhead valve or I-head engines.
- Tool has a throat depth of 6-1/4" and jaw openings 3 to 5-3/8".
- It's designed for light weight valve springs.
- Compressor works on I-heads with manifolds removed and many industrial engines.



AI020017 VALVE SPRING COMPRESSOR FOR TRUCK

- Larger design to use on the enging which valve spring exposed outside.
- With straight and bend jaws.
- Applicable:12 V engine, Diesel engine...



AI020018 VALVE SPRING COMPRESSOR FOR TRUCK

- Compress valve springs on overhead valve and L-head engines on cars, trucks and tractors. Tool has a 9-3/4" throat depth, and jaw openings 2-3/4 to 7-3/4" fit larger engine sizes. Jaws and plunger bar are easily adjusted. Plunger bar seats on both flat- and cup-shaped valve heads. Offset and Straight Jaws are included. Use these heat-treated jaws with 380 and 383 Valve Spring Compressors.



AI020024 VALVE SPRING COMPRESSOR

- For large engines & diesel engines.
- Unique direct action compressor lever gives improved visibility & ease of use in areas of difficult access.
- Collet release adapters : restricted access adapter, 25MM, 30MM.



AI020056A EXTRA LONG VALVE STEM SEAL PLIERS

- Long neck designed to reach into confined area of the seal to grip it for removal.
- Gripping serration allow to grasp both original equipment & aftermarket seals regardless of the configuration.



AI020049 UNIVERSAL OVERHEAD CAM VALVE SPRING COMPRESSOR

- For use on most foreign & domestic engines, including AUDI, CHRYSLER, INFINITI, HONDA, HYUNDAI, LEXUS, MAZDA, MITSUBISHI, NISSAN, PORSCHE, SATURN, TOYOTA, VOLVO & VOLKSWAGEN
- This is a kit included everything you need to remove & install the valve spring with the cylinder head on or off the OHV & OHC petrol or diesel engine. An ideal tool kit for most foreign & domestic engines. The multi-point adjustable base of this tool bolted security to the head while the adjustable lever mechanism pivots from the beam thus compressing the spring quickly by one hand operation, fast removal & installation of the spring retaining keepers is easily accomplished by hand through the large open on both sides of the compressing tube. This kit allows on car servicing.



AI020050 HEAVY-DUTY VALVE SPRING COMPRESSOR

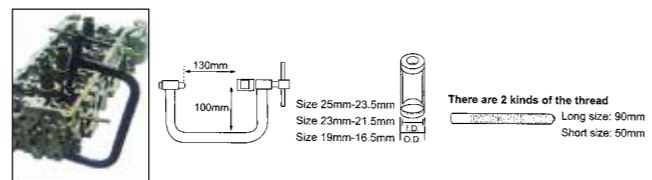

AI020034-37 PISTON RING COMPRESSOR

ITEM NO.	HEIGHT	CAPACITY (MM)	Q'TY		N.W kgs	G.W. kgs	CUFT
			Q'TY	Q'TY			
AI020034	3"	53-125	30	60	16	17.5	2.0'
AI020035	3"	90-175	30	60	18	19.5	2.0'
AI020037	6"	90-175	20	40	23.5	25	3.0'

- Special spring steel
- Heat-treated
- Ratchet type complete with spanner
- With safety adjusting screws



AI020040-42 PISTON RING COMPRESSOR

ITEM NO.	HEIGHT	CAPACITY (MM)	Q'TY		N.W kgs	G.W. kgs	CUFT
			INNER	CTN			
AI020040	3"	90-175	30	60	18	19.5	2.0'
AI020041	4"	90-175	30	60	20.5	22	2.6'
AI020042	6"	90-175	20	40	23.5	25	3.0'

- Compression band stainless steel
- Ratchet type complete with spanner
- With adjustable safety screws



AI020063 VALVE SEAL REMOVAL & INSTALLER KIT

- Works on both valves steel seated or removed. Fine gripping serrated plier grasp both original equipment or aftermarket seals regardless of their configuration. Precision machined seal driving adapters guide the seal for proper setting.
- Contents :
 1PC- Valve stem seal plier.
 1PC- Drive handle 6" (150mm) long.
 2PCS- Deep seal driving sockets for seals O.D. 10.8-14.8mm.
 7PCS- Seal driving adapters fit seals 5,5.5,6,6.6,7,8, & 3/8".



A1020051 DIESEL ENGINE COMPRESSION TESTER SET (CARS)

- APPLICATIONS : BMW/MERCEDES-BENZ/CARBODIES/MITSUBISHI/CITROEN/NISSAN/DACIA/OPEL/DIAHATSU/PEUGEOT/FLAT/RENAULT/FORD/ROVER/HOLDEN/SEAT/ISUZU/TOYOTA/LAND ROVER/VAUXHALL/LEYLAND / DAF/VOLKSWAGEN MAZDA/ VOLVO
- CONTENTS :

DESCRIPTION	OVERALL LENGTH	GAUGE DIAMETER	SCALE
Gauge Assembly	560	83 THREAD	0-60 BAR OUTSIDE DIA
GLOWPLUG ADAPTER	73.5	M10 X 1.0	
GLOWPLUG ADAPTER	54	M12 X 1.25	
GLOWPLUG ADAPTER	72	M14 X 1.25	
DUMMY INJECTOR	114	N / A	21
STANDYNE DUMMY	112	N / A	19
GLOWPLUG ADAPTER	114.5	M10 X 1.0	
GLOWPLUG ADAPTER	119	M10 X 1.0	
DUMMY INJECTOR	78	M20 X 1.5	

REPLACEMENT SEAL AND WASHER SET :

90° ELBOW	LENGTH	WIDTH	HOLE
DIAMETER			
Clamp plate	63.5	25	17

- Comprehensive test kit for both direct and indirect diesel injected cars.
- Simple & easy to use.
- For use on both direct or indirect injection engines.
- Checks engine compression under cranking conditions.
- Small profile, quick coupling adapters for speed & security.
- Built-in pressure relief valve enables repeat tests without dismantling.
- Flexible hose (355mm) gives access to restricted plug & injector parts.
- Dual scale 80mm dia gauge 0-1000 lb / in² & 0-70 bar.



A1020052 PETROL ENGINE COMPRESSION TESTER SET

- CONTENTS :
- Compression Tester-General Purpose M14 & M18 Plug Ports
M14 & M18 Thread Chaser,M10 & M12 Thread Chaser
M10 Extension,M12 Extension,M14 Extension
M14 Extension,M18 Extension,Service Kit.
- Comprehensive kit is based on petrol compression tester for vehicles with M10, M12, M14, and M18 spark plug threads. Complete with extensions, thread chasers and service kit.
 - Easy to use.
 - Checks condition of valves, piston rings, gaskets & cylinder heads.
 - Used on cars, vans & motorcycles.
 - Pressure relief valve enables repeated testing of a cylinder without removing the gauge.

A1020053 DIESEL ENGINE COMPRESSION TESTER SET (C.V.S)

DESCRIPTION	OVERALL LENGTH	GAUGE DIAMETER	SCALE
Gauge Assembly	560	100 THREAD	0-60 BAR EXT. THREAD
Center Pillar Spacer Set	185	5/16 x 24 UNF	1/2 X 20 UNF
	EXT. DIAMETER	LENGTH	
End Adapter	20.5	30	
End Adapter	23.6	32	
End Adapter	23.6	41	

REPLACEMENT SEAL AND WASHER SET :

LENGTH	WIDTH	HOLE DIAMETER
Clamp plate	63.5	25
Clamp plate	76.2	15
90° ELBOW		17



A1020054 OIL PRESSURE TESTER SET

- CONTENTS :
- GAUGE ASSEMBLY :
OVERALL LENGTH 1300 mm GAUGE DIAMETER 80mm SCALE 0-10 bar
- ADAPTERS :
THREAD,R1/8 DIN 2999,1/8 X 27 NPT,1/4 X 18 NPT, 3/8 X 20 UNF
1/2 X 20 UNF, M10 X 10, M12 X 1.5, M14 X 1.5, M16 X 1.5, M18 X 1.5, 90° ELBOW
- Helps to diagnose worn oil pumps and engines, faulty oil pressure switches and warning indicators.
 - Easy to use.
 - Accurately tests oil pump pressure, switch & warning indicators.
 - Large clear dual scaled gauge.
 - Quick coupling adapters with shut-off valve for speed & security.
 - Permanently oil primed, long, flexible hose.



A1020061 TRANSMISSION PRESSURE GAUGE SET

- PARTS LIST :
- 0~100 PSI low pressure gauge assembly x 1.
 - 0~500 PSI high pressure gauge assembly x 1.
 - Adapter hose 1/8-27 NPT x 1.
 - Adapter 1/8-27 to 1/4-18 NPT x 1.
 - Adapter 1/8-27 to 1/8-28 NPT x 1.
 - Adapter 1/8-27 to 10-10 x 1.
 - Fitting 1/8-27 90° steering elbow x 1.
 - Fitting 1/8-27 nipple 2" long x 1.
 - Fitting 1/8-27 coupling x 1.
 - Adapter 1/8-27 to M8-1.0 x 1.
 - Adapter 1/8-27 to M8-1.25 x 1.
 - Adapter 1/8-27 to 5/16-24 NF x 1.
 - Adapter 1/8-27 to 1/16-27 NPT x 1.
 - Fitting 1/8-27 45° steering elbow x 1.
 - Adapter 1/8-27 to VW AUDI x 1.
 - For all major manufacturer domestic and import vehicles.
 - Pack in a plastic storage case
 - Packing : 1Set/White box 6Set/Ctn N.W. 15.5kg G.W. : 16.5kg CUFT :3'
- Set contains two gauge assemblies for high and low pressure ranges. Nine adapters to test a wide variety of domestic and import automatic transmissions. Four special fittings are also included for connection to hard-to reach test parts in areas requiring a 45 to 90 angle.



A1020138 PETROL & DIESEL ENGINE COMPRESSION AND LEAKAGE TEST KIT

- This petrol & diesel engine compression and cylinder leakage test kits that cover the wide range of modern engines, including Hdi, TDCi and Pumpe Duse.
- Included clamp-on injector adaptors, 0-50 Bar (700PSI) gauge with rubber bumper, staright and right angled quick connect fitting and an extensive range of glow plug and injector adaptors enable this kit to cover the vast majority of car, van, truck, and bus, agricultural and marine diesel engines.
- Additional pressure gauge for references on incoming pressure during the operation (0-7bar).
- Glow Plug Adaptors: Wide range of Alfa, BMW, Chrysler, Daewoo, Fiat, Ford, Hyundai, Isuzu, Land Rover, LDV, Mazda, Mercedes, Mitsubishi, Nissan, Opel, PSA, Renault, Saab, Suzuki, Toyota, VAG, Vauxhall, Volvo diesel engines.
- Spark plug size : 10 , 12 , 14 , 18mm.
- Injector: M20, M22, M24 & Ford Stanadyne injector plus clamp-on injector.



A1020141 DIESEL ENGINE COMPRESSION TESTER SET

- Comprehensive test kit for both direct and indirect diesel injected cars.
- Simple & easy to use.
- For use on both direct or indirect injection engines.
- Checks engine compression under cranking conditions.
- Small profile, quick coupling adapters for speed & security.
- Built-in pressure relief valve enables repeat tests without dismantling.
- Flexible hose(355MM) gives access to restricted plug & injector ports.
- Dual scale 80MM DIA gauge 0-1000 PSI& 0-70 kg/cm².



AI020064A FUEL INJECTION TEST KIT

QTY	DESC.	QTY	DESC.
1	1/4x1/4 inch pipe plug	1	13 inch Ford adapter hose
2	5/16x1/4 inch NPT hose barb	1	bleed-off hose
2	1/4x1/4 inch NPT hose barb	1	bosch C.I.S. hose
1	0-50 PSI (0-3.5 bar) gauge	1	basic hose, 24 inch
1	0-100 PSI (0-7 bar) gauge	1	8mm-1.0 banjo bolt adapter
4	hose clamps	1	10mm-1.0 banjo bolt adapter
1	5/16 inch hose	1	12mm-1.25 banjo bolt adapter
1	1/4 inch hose	1	10mm-1.50 banjo bolt adapter
1	FORD spring lock adapter	1	HONDA adapter
1	1/4 inch NPT tee with valve	1	12mm-1.50malex10mm-1.00femalex1-1/4"adapter
1	G.T.T.B.I. adapter	1	12mm-1.50malex10mm-1.00femalex1-1/4"adapter
1	G.M quick connect adapter	1	12mm-1.50malex8mm-1.00femalex5/16"adapter
1	G.M 2.2L adapter	2	12mm-1.50malex8mm-1.00maleadapter
1	FORD hair pin adapter	1	12mm-1.50malex8mm-1.00malex3"adapter

- The fuel injection test kit tests fuel injection systems on vehicles on most makes and models.
- Pinpoints problems in filters, lines and regulators.
- This kit comes complete with assorted hoses, hose barb fittings and hose clamps to adapt to earlier vehicle models, as well as current.



AI020074 CYLINDER LEAK DETECTOR AND CRANK STOPPER

- Kit allows easy identification of compression problems.
- Detector measures exact leakage amount and locates leaks area.
- Crank stopper locks engine harmonic balance pulleys and replacing spark plugs.



AI020103 DIESEL INJECTOR PULLER

- Assists removal of stubborn bosch and lucas diesel injectors-saves time and money when injectors are difficult to remove.
- With M8, M12, M14, adaptors.



AI020125 SLIDE HAMMER TYPE INJECTOR NOZZLE PULLER

- Can Use For Mercedes Cdi Engines Om 611, 612, 613,... etc.
- Injection Nozeles That Do Not Fit Very Tightly Can Be Pulled Out Without Needing To Take Them Apart Or Remove The Cylinder Block.
- The Specialty Design , The Puller Is Additionally Supported By The Steel Ball On The Valve Cover, Which Prevents The Puller From Tipping During The Removal Process.



AI020065 VALVE REFRACTING AND SEATING TOOLS

Precision machined tungsten carbide blades produce valve seats with:

- Accurate seat angle
 - Superior seat surface
 - True, flat seal
 - Seats concentric with valve guide
- Available in a wide range of cutter diameters and angles, Contents :

- cutter $\phi 52\text{mm}$ - $\phi 65\text{mm}$ 75° and 60°
- cutter $\phi 46\text{mm}$ - $\phi 60\text{mm}$ 45° and 30°
- cutter $\phi 44\text{mm}$ - $\phi 52\text{mm}$ 75° and 30°
- cutter $\phi 37\text{mm}$ - $\phi 46\text{mm}$ 60° and 45°
- cutter $\phi 37\text{mm}$ - $\phi 44\text{mm}$ 75° and 30°
- cutter $\phi 28\text{mm}$ - $\phi 35\text{mm}$ 75° and 45°
- 5 pcs expandable pilot $\phi 5.5\text{mm}$ - $\phi 12.5\text{mm}$
- "T" wrench handle

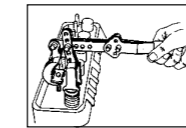

AI020027 VALVE SPRING COMPRESSOR

- Compresses overhead valve springs with rocker arm studs.
- This tool can be used with the head either on or off the engine.
- Jaws adjust to fit most domestic and import overhead valve engines.
- Adjustable handle allows for clearance in tight areas, comes complete with stud adapter.



AI020043 BANDING TOOL WITH CUTTER

- Operated by hand or 1/2" wrench.
- This tool is easily removed by sliding sideways after winding has been completed.

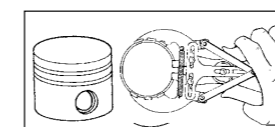

AI020019 STANDARD PISTON RING EXPANDER CAPACITY : 4-1/2" TO 7" (115-180MM)

AI020020 STANDARD PISTON RING EXPANDER CAPACITY : 2-3/4" TO 4-1/4" (70-108MM)

AI020021 STANDARD PISTON RING EXPANDER CAPACITY : 2" TO 4" (50-100MM)

- Replace piston rings without the danger of breakage or destroy.
- It doesn't need adjustment, and expands all ring styles whether square, diagonal or step - cut style.



AI030010 VALVE LAPPERS

AI030010 has 1-1/8" and 1-3/8" dia. Cup for Larger valves



AI030002 12PCS DRAIN PLUG KEY SET

- Remove & install female drain plugs.
- All drain plug keys have 3/4" (19mm) hexagon body for use with socket or T-bar to drive.
- Chrome-Vanadium Steel heat-treated & black finish.



AI030014 MECHANICS STETHOSCOPE

- Locates source of engine noise quickly.
- Listen for trouble by tracing sound of flowing water, oil, gas or steam.
- Identify piston slap, worn gears, faulty valves, water pump failure, damaged gaskets and defective bearing.
- Handle is shockproof.
- Disassembles for storage.



AI030020 MECHANICS STETHOSCOPE

- Use on any application where securing a pulley is required.
- Especially useful in removing fan clutches
- Eliminates the need for multiple various sized holding wrenches.
- Saves time and money.



AI030027 6PCS PICK AND HOOK SET

- Straight, hook, combination
- Cotter key puller
- 45 & 90 degree large pick & hook
- Organizational tray
- Advanced tri-lobal ergonomic design handle increases torque and provides comfort while reducing fatigue.
- TPE (thermal plastic elastomer) over-mold ensures firm grip
- Resistant to acids, fluids and solvents
- Extra long 18" shaft for added reach
- Large 5/16" (8mm) shaft diameter for added strength
- Chrome-Vanadium steel shafts with high-polished chrome plated finish

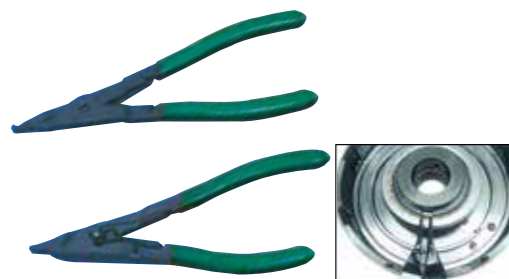

AI040005 LOCK RING PLIERS (ANGLE TIP)

AI040006 LOCK RING PLIERS (STRAIGHT TIP)

- Removing & installing all types of lock rings.
- Used in brakes, transmission, pedal shafts, clutches shaft.
- Deep serration jaws hold lock rings securely.



AI040017 HEAVY-DUTY 10-1/2" REPLACEABLE TIP CIRCLIP PLIERS SET

Q'TY	TIP SIZE	TIP ANGLE
2	108	0°
2	108	15°
2	108	45°
2	108	90°
2	120	0°
2	120	15°
2	120	45°
2	120	90°

Replacement Tips :
Includes 2 Each 108 tips in 0° 15° 45° 90°
Includes 2 Each 120 tips in 0° 15° 45° 90°

- Replaceable tips and have a spring ratchet locking mechanism to hold circlip securely against tension. Offset tips make it easier to facilitate circlip.



AI040008 VACUUM TESTING/BRAKE BLEEDING KIT

- The kit includes the vacuum pump, complete fittings and accessories for vacuum testing and brake bleeding, plus a detailed owners manual.
- The vacuum pump is field repairable. Replace worn "o" ring, seals and valves with the vacuum pump repair kit.



AI040031 DUAL VACUUM & PRESSURE PUMP WITH BRAKE BLEEDER KIT

- Quality all metal construction vacuum & pressure pump creates and holds a metered vacuum and or pressure for testing a wide variety of automotive, marine, aircraft & agricultural equipment. Simply set the serrate control valve from vacuum to pressure for intended use.
- **There's infinite number of applications** : air intake control valves, distributor vacuum advances, EGR valves, power brake boosters, transmission modulators, motorcycle carburetors, etc. Includes all adaptors and reservoir for brake bleeding & fluid transfer.
- **Gauge Diameter** : 2"(50mm) Readings : 0 to 30in Hg (0 to -1 bar) Vacuum 0 to 60 psi (0 to 1.4 bar) pressure



AI050002 OIL FILTER WRENCH 3-LEG, 2-WAY

- 3 leg two way size : 65mm to 120mm, (2-1/2" to 4").
- 3/8" & 1/2" square drive with 19mm male hexagon adapter.



A1050004A 30PCS CUP TYPE OIL FILTER WRENCH KIT

ITEM NO.	SIZE MM	FLUTES	SUITABLE FOR MOTORCAR
HC-66/6	66 (2-19/32")	6	Fiat (Punto, 1-2) Renault (Clio 1.2 Express, Kangoo, Rapid, Twingo)
HC-68/14	68 (2-11/16")	14	Fits Hastings. Mazda, Ford Escort, Capri, Subaru, Fran PH6607 (those Fram filters made in Korea), Motorcraft FL816
HC-73/14	73 (2-7/8")	14	Fits Toyota/Lexus
HC-76/12	76 (3")	12	Fiat (z.B. Ducato, Scudo, Ulysee), Renault, (Megane, Laguna, Espace 3)
HC-76/14	76 (3")	14	Fits Champion, Champ Lee, Purolator, Mopar, VW, Porsche, Mercedes, Benz, BMW, Audi, (L.B. A3TD) Opel.
HC-76/30	76 (3")	30	Fits Motorcraft only-FL400A, Ford
HC-76/8	76 (3")	8	Fiat (z.B. Marea), Lancia (z.B. Delta)
HC-80/15	80 (3-9/64")	15	Fits Hastings, Fram, Purolator, Nissan, Honda, Motorcraft, Mazda, Isuzu, Subaru, Opel, Toyota.
HC-86/16	86 (3-3/8")	16	Volvo (S40, S60, S70, S80)
HC-86/18	86 (3-3/8")	18	VW Golf (MK3, Tdi, passat Tdi.) Audi A6 Tdi, Renault (Clio, Rapid 1.9D Laguna, Safrane, Espace 2.1D) Citroen, Peugeot, Renault
HC-90/15	90 (3-17/32")	15	Fits Honda Accord, Mitsubishi, Mopar, Isuzu
HC-92/10	92 (3-40/64")	10	Fiat, Cinquecento, Coupe, Croma, Fiat, Panda, Regata, Ritmo Fiat, Seicento, Tempra, Tipo, Lancia (Beta, Dedra, Kappa, Monte Carlo, Prisma Thema, Trevi)
HC-93/15	93 (3-21/32")	15	Fits Casite, Champ, Champion, GM, Fram, Hastings, Opel, Mazda, Volvo, Mitsubishi, Purolator, Wix, Nissan, VW, Porsche, Renault Ford, Honda, Audi
HC-93/45	93 (3-21/32")	45	VW-Audi. (TDI 2.4, 2.6, 2.8L)

ITEM NO.	SIZE MM	FLUTES	SUITABLE FOR MOTORCAR
HC-95/15	95 (3-6/8")	15	Toyota #15600-41010, Alfa, GM, Ford, ALFA, Chrysler
HC-96/18	96 (3-3/4")	18	Audi (A4, A6, Tdi), VW (Passat 97 Tdi) Renault (Laguna 2.2d, Safrane 2.2D Espace 2.2D, R19, Rapid, Megane, 1.9/2.1D, Tdi)
HC-100/15	100 (4")	15	Fits Fram, Motorcraft, Wix, Isuzu and Mitsubishi,
HC-106/15	106 (4-11/64")	15	Fiat (Ducato 2.5D, Td)
HC-108/15	108 (4-8/32")	15	Volvo (C70, S70, V70, Tdi, TD) (Turbo, Diesel, 850 Tdi, Diesel) etc...
HC-108/18	108 (4-8/32")	18	Renault (Espace, Laguna, Master, Safrane, Traffic 2.4, 2.5, 2.8D, TD)
HC-65/67	65 to 67mm (2-9/16" to 2-21/32")	14	Fits same filters as made in Canada including PH4386, PH4967, PH6017, PH6018, Daihatsu.
HC-74/15	74mm (3-29/32")	15	MF, Audi, #056-115-561G, gm, Rover, Chrysler.
HC-74/76	74 to 76mm (3-29/32" to 3")	15	Fits Fram, Ac, Saturn
HC-75/77	75 to 77mm (3-15/16" to 3-1/32")	15	Fits VW, Audi, Castie, GM/AC, Hastings, Wix, NAPA Ford, Isuzu Mercedes, Opel.
HC-78/15	78mm (3-2/32")	15	Nissan #15208H8991, Ford, Toyota, Accord.
HC-80/82	80 to 82(3-9/64" to 3-7/32")	15	Fits Wix filters branded for mazda, Subaru, Toyota, Honda, Acura, Nissan, NAPA.
HC-93/36	93mm (3-21/32")	36	Fits Motorcraft only FL1A, FLA1B, FL300, FL820, Ford
HC-65103	Two Way Oil Filter Wrench 65-120mm		
HC-9.5mm	Adapter 1/2"(F) or 3/8"(M) Square drive tool		



A1050007 PROFESSIONAL SWIVEL HANDLE OIL FILTER WRENCH

ITEM NO.	CAPACITY
A1050007A	2-3/8" ~ 2-7/8" (60mm ~ 73mm)
A1050007B	2-7/8" ~ 3-3/8" (73mm ~ 85mm)
A1050007C	3-3/8" ~ 3-3/4" (85mm ~ 95mm)
A1050007D	3-3/4" ~ 4-3/8" (95mm ~ 110mm)



A1050043 OIL FILTER MASTER PLIERS

- Multi-purpose pliers 2-1/8" to 4-5/8" (53-118mm)
- Chrome Vanadium Steel
- Drop forged jaws with heat-treated, nickle plated
- Suitable for installing, removing and tightening objects of any shape.
- Locks onto the work with terrific grip.



A1050008 12" ADJUSTABLE OIL FILTER WRENCH SIZE : 60-115MM



A1050049 CHAIN WRENCH

- Size : 30-160mm
- Handle 9"
- Chain 23-3/8"



A1050109 HEAVY DUTY OIL FILTER CHAIN WRENCH

- Available for all type of oil filter
- Flexible handle for narrow space
- Size available: Ø 60~105mm/m
- Length of chain: 350 m/m



A1050030 FILTER WRENCH (FROM 2-1/2" TO 3-1/8" 60MM~80MM)

- Steel jaw grip filter is no slipping.
- The large range enable to fit most standard size filters.
- Use with 3/8" drive.



A1050024 4PCS PRY BAR SET

Contents :
17/16" X 24" , 7/16" X 18" , 3/8" X 12" , 1/4" X 8"



AI050043S 3PCS STAINLESS STEEL SCRAPER KNIFE KIT
 SIZE : 15, 20, 30MM



AI050080 1/2" X M9 CYLINDER HEAD BOLT TOOL

- The 100mm length allows easy access to recessed head bolts.
- Comes with 1/2" drive for use with a torque wrench.
- Use for TOYOTA TERCEL cylinder head bolt.



AI050092 EXTRA LONG SPARK PLUG 3/8"DR. X14MM HEX L : 250MM

- Designed for use with deep-seated spark plugs.
- 250mm long, 3/8"sq drive, bi-hex socket.



AI050093 EXTRA LONG SPARK PLUG 3/8"DR. X16MM HEX L : 250MM

- Designed for use with deep-seated spark plugs.
- 250mm long, 3/8"sq drive, bi-hex socket.



AI050096 7PC SENSOR SENDING UNIT SOCKET SET

- A • 1" & 1-1/16" Oil pressure sending unit socket
- B • 1-3/16" Oil pressure sending unit socket
- C • 1-1/16" GM thermal sensor switch socket
- D • 7/8" Heated oxygen sensor socket
- E • 7/8" Low profile offset oxygen sensor socket
- F • 7/8" Oxygen sensor socket
- G • 7/8" Universal vacuum PVS, TVS valve and oxygen sensor socket



AI050112 5 PCS 1/2" SQ. DRIVE STAR-E INSERT SOCKET SET

- Length - 140MM : E10, E12, E14, E16, E18



AI050104 OXYGEN SENSOR FLEXIBLE SOCKET WRENCH(22MM)

- Max torque : 25Kg-m



AB010001 WINDSHIELD INSTALLATION KIT

Specifications :

- A. Rope Insert Tool
Use this tool to insert the rope into rubber gasket. The handle feeds rope through its stem as you pull it around the gasket.
- B. Assort Tip For Insert Tool :
For inserting locked strip into windshield seal. Different shaped heads interchange for most types of locking strip.
- C. Curved Hook Tool :
Curved hook tool used for inserting and cleaning rubber gaskets.
- D. Straight hook tool used for inserting and cleaning rubber gaskets.
- E. Cleaning Tool :
Designed for the removal of broken glass for the side runners without removing them.



AB010002 WINDSHIELD REMOVAL KIT

Specifications :

- A. Wire.
Three strong galvanized steel wires are braided to form one wire.
- B. Wire Gripping Handles x2 pcs :
A & B Feed the wire through the hole in the wedge shaft. Loop it through the hole at the top of the shaft. Then back into the handle. Pressing the wedge back into the handle, the wire is hold.
- C. Windshield Removal Tool :
Cuts the butyl adhesive compound around windshield.
- D. Wire Feeder Tool :
Designed for easy and flexible insertion of wire through polyurethane, allowing speedy removal of bonded windshield.
- E. Trim Pad Remover :
Place the tool under the edge of the door upholstery panel and insert it into the fastener as far as possible, then simple pack pry up.
- F. Windshield Molding Release Tool :
Use for removal of Windshield molding.

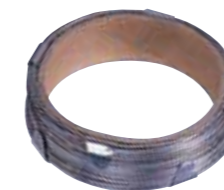

AB010013 WINDSHIELD CUT-OUT WIRE



AB010026S 5 PCS HANDY REMOVER SET

Contents :

- AB010026A : wedge set
- AB010026B : wedge set
- AB010026C : handy remover
- AB010026D : remover wide type
- AB010026E : remover pull type



AB020003 SUCTION LIFTER WITH TWO VACUUM CUP

- Lever operated vacuums
- 2 x120mm diameter rubber suction cups
- Lifting action will not damage contact surface
- For use on windscreens glass,tiles,plastic, or other smooth surfaced non-porous materials.



AB030038A LIFT SUPPORT FIXING CLAMP

- To fix the engine. For trunk and back door lift support
- To prevent the from slip.
- Place the tool on the lift rod next to the cylinder. After the work finished, tighten with the knob until it is secured on the lift rod.



AB030056 AIR INFLATE FOR UNLOCK DOOR (VEHICLE)

- This inflate design easily and safely to separate the door frame from the vehicle body.

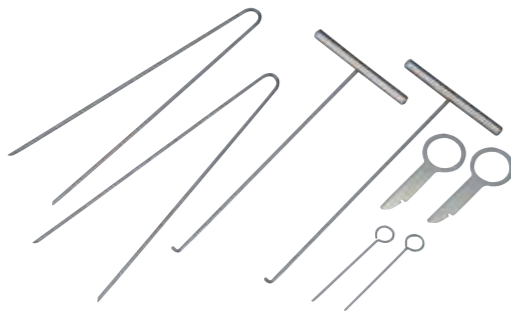

AB030024 IGNITION LOCK & RADIO & HOOK TOOL SET

- Ignition Lock Removal Tool Set
Contains : 2 removal tools for Model W 126 ; 2 removal tools for Models W 124 & 201
- Pair of Hooks
For removing instrument cluster. Applicable : Models W 107, 116, 123, 124, 126, 140 & 201
- Radio removal tool
To radio removal on 1992 and newer MERCEDES.
Applicable : Models 140, 129, 202 & 210



AB030028 CAR DOOR UPHOLSTERY REMOVER

- Removes upholstery clips in seconds.
- This perfectly balanced alloy forged tool is attached with plastic handle, with a bright plated blade.



AB030058 CLIP REMOVAL PLIERS (35 DEGREE)

- To remove trim pads & insulation
- To keep from breaking clips
- To remove the "tough" clips

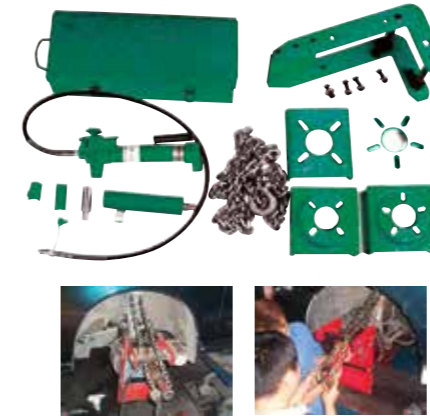
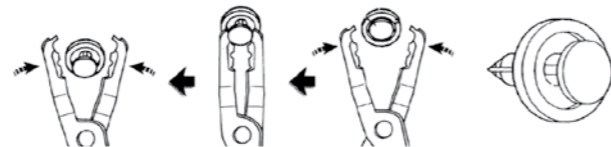

AL010004 ANGLE ADJUSTER

- With 4pcs alignment plates.
- Hydraulic function.
- Suit for most car.
- NW : 31kgs GW : 32 kgs
- The purpose of wheel alignment is to reduce tire wear, improves fuel economy and handling, while increasing driving enjoyment and safety by proper adjusting the angles of the wheels, suspension system, and steering system.
- Used in conjunction with AG010119



AL010005 DOUBLE WISHBONE ALIGNMENT TOOLS (IMPROVEMENT)

- Applicable : MERCEDES, MITSUBISHI, HONDAS, and all double wishbone suspension vehicles.
- Features : with two spacers to adjust the angle. On car maintenance without removing double wishbone. No damage to hub bearing. Fixed with c-type strong clamp, it works as 10 ton hydraulic press. Used on both front and rear suspension double wishbone. 10 ton two-speed hydraulic pump makes the maintenance easy and accurate. This is time, money, and labor saver. N.W. : 29.1 kgs G.W. :30 kgs



AN010227 WHEEL ALIGNMENT WITH DIGITAL PROTRACTOR

- Perform portable , no heavy turntable ! One person operation.
- Displays camber ; caster ; KPI ; toe
- Includes gauge and wheel mount (from 10" to 20")
- Accurate, rugged and easy to use
- Saves time and money!





AN01001C 18PCS CALIPER WIND BACK TOOL KIT
 SERVICES : MERCEDES, BMW, VW, GM, AUDI, FORD, HONDA, SUBARU, MAZDA, NISSAN, MITSUBISHI, TOYOTA, ROVER, 4WD, RENAUL, OPEL.

- Rear disc brake caliper tool.
- For rotating pistons back into the caliper to provide clearance for new pads.
- Includes 9 adapters (Available individually) for use in both 2 and 4-wheel rear disc rake assemblies of most domestic and import cars.
- Tool may be used "on" or "off" the car. A real time saver that makes this tough job easy. Helps prevent damage to the piston and boot.



AN010070 REAR DISC BRAKE CALIPER TOOL

- For rotating pistons back into the caliper to provide clearance for new pads.
 - Includes 5 adapters for use in both 2 and 4-wheel rear disc brake assemblies most of cars.
 - Tool may be used "ON" or "OFF" the car. A real time saver that makes this tough job easy helps prevent damage to the piston and boot.
- Contents use including :
 Most HONDAS, MAZDAS, DODGE, MITUBISHI, SUBARU, TOYOTA, FORD & GM etc.



AN010038 SEAL PULLER

- Removes oil & grease seals
- Two tips fit most application.
- NW : 0.36 kg



AN010183 UNIVERSAL TRANSMISSION CLUTCH SPRING COMPRESSOR

- For removing and installing the transmission clutch piston snap ring.
- Adjustable, for most models of European, Japanese and American cars and light trucks.
- Accessory 01 can be used on BENZ transmission rear clutch piston snap ring...
- Accessory 02, the wide are plate, for use on all types and models of American and Japanese car automatic transmission clutch drums. For example: FORD, TOYOTA, MITSUBISHI...etc.
- Accessory 03, the middle are plate, for use on most models of American cars and light trucks.
- Accessory 04, small are plate, for use on BMW (4HP22, 5HP18..), VW, FORD, MONDEO (CD4E)...etc.
- Accessory 05, the body of this tool: L300mm x W300mm x H330mm.



AN010145 4 IN 1 BALL JOINT SERVICE TOOLS SET

- For universal joints and anchor pins remove and install.
- Easy operate to the upper and lower ball joints on 1/2 and 3/4 ton pickups, Suburbans, and Yukons / Tahoes.
- Work on both original equipment and aftermarket ball joints.

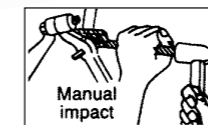

AN010045 BALL JOINT SEPARATOR

- Placed between ball joint and steering knuckle and give a few sharp blows with a hammer.
- Forged and heat treated 15/16" Opening Length : 12".



AN010091A INNER TIE ROD TOOL

- These tools are specially designed for the inner tie rods that are inaccessible to adjust.
- The long socket can be easily used with seven open-jaw drivers, size 1-3/16", 1-1/4", 1-5/16", 1-7/16" & 14mm, 17mm, 33.6mm, to most application.
- The inner tie rod can be easily removed and installed by slipping the long socket over tie rod end and connecting it to the open-jaw driver.



AN010092 MULTI-PURPOSE INNER TIE ROD TOOL

- The master tie rod tools easily replaces inner tie rod ends without removing the rack & pinion.
- Capacity : 33-42mm Patented.



AN010185 CV BOOT CLAMP PLIERS

- FOR ALL EAR-TYPE CLAMPS
- APPLICATION: FOR AUDI, BMW, CHRYSLER, FORD, GM, HONDA, MAZDA, MERCEDES BENZ, NISSAN, OPEL/VAUXHALL, VW ETC.
- DESIGNED: TO USE WITH EXTENSION HANDLE OR TORQUE WRENCH



AN010008 BEARING RACE & SEAL DRIVER SET

- Collars : 9 sizes : 1.565", 1.750", 1.965", 2.325", 2.555", 2.470", 2.8230", 2.995", 3.180".
- 6 sizes fit most bearing race sizes #1 - #6.
- Help reduce damage to both race and axle housing.

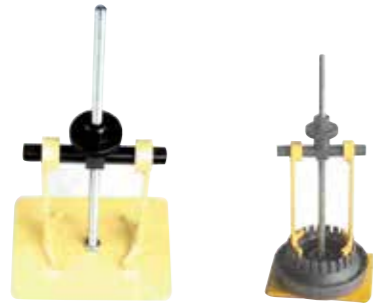

AN010012A AUTOMATIC TRANSMISSION CLUTCH SPRING COMPRESSOR (IMPROVEMENT)

- For removing and installing the transmission rear clutch piston snap ring...
- Adjustable, for most models of American cars and light trucks.
- NW : 3.2 kgs GW : 3.4 kgs



AN010054A 3PCS COMPOSITE HOSE PINCH TOOL SET

- Special-radius jaws design will not damage internal hose lining.
- Lightweight, non-conductive, bright color 3 sizes for different application.

Size : 1/2" - 1 1/4"
1/4" - 3/4"
3/4" - 2 1/4"



AN010085A SNAP IN TIRE VALVE INSTALLER

- Steel constructed tool with deep threaded head for positive sealing of all snap-in type passenger car tire valve stems.
- Rubber cover design to protect the rim.
- 3 position settled Patented.



AN010030A WHEEL WEIGHT BALANCE PLIERS

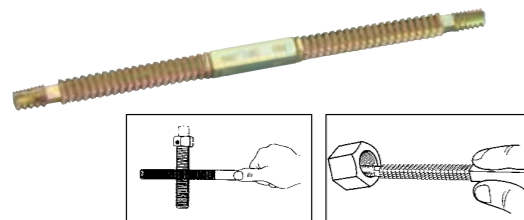

AN010072 EXTERNAL & INTERNAL RESTORER FILES

- Restore tool for renewing damaged thread on any diameter bolt, stud, axle or shaft file both right and left hand threads.
- Design for in hole & narrow area usage.
- Description pitch sizes
- Metric file 0.80 , 1.00 , 1.25 , 1.50 , 1.75 , 2.00 , 3.00



AN010072A/B/C EXTERNAL THREAD RESTORING FILES

- Restore tool for renewing damaged thread on any diameter bolt, stud, axle or shaft file both right and left hand threads.

	Description	pitch sizes
AN010072A	Metric file	0.75, 1.00, 1.25, 1.50, 1.75, 2.00, 2.50, 3.0mm
AN010072B	SAE file	11, 12, 13, 14, 16, 18, 20, 24
AN010072C	SAE file	9, 10, 12, 16, 20, 27, 28, 32



AN010188A TIRE LEVER WRENCH

- CHROME VANADIUM CARBON STEEL S45C MAT FINISHED

ITEM NO.	L	T	WT
AN010188A	500	8.3	732



AN010064 OVERHEAD VALVE SPRING COMPRESSOR

- For use on a wide range of OHV, OHC and CVH engines not suitable for use on engines with deep seated valves.
- Allow valve springs and valve stem oil seals to be replaced with the cylinder head.
- Feature a reversible jaw/adaptor and automatic cam-action locking to a pre-determined setting.

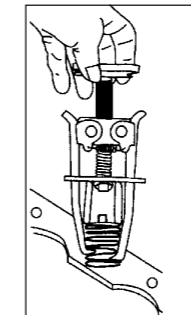

AN010064A VALVE SPRING COMPRESSOR

- Compressor easily removes valve springs on most cars and light trucks, works with cylinder head on or off the engine.

Instructions :

- Remove valve cover.
- Place tool around valve spring as low as possible to fit spring coils.
- Screw down handle until spring is compressed sufficiently to remove keys and spring.



AN010066 A/C COMPRESSOR CLUTCH REMOVER KIT

- Replace clutches found on FS6, C171, 6P & 148 computer.
- Also GM R4 & A6, HR-6, DA-6 & V5 A/C compressors.
- And compressors of Sanden SD505, 507, 508, 510, 575, 708 and 709.
- 2 & 3 hole puller plate fits most clutches, the mechanical force does the pulling job.



AN020007 STANDARD ENGINE CYLINDER HONE

- 3 Leg 2" - 7" (51MM - 177MM)



AN040100 PEUGEOT/CITROEN PENTAGON BRAKE SOCKET (12.5MM)

Applicable: For use on bendix brakes on PEUGEOT and CITRONE vehicles.



AN040101 PENTAGON SOCKET BIT FOR GIRLING BRAKES(1/2" DR.)

- For use on most vehicles fitting with girling brake systems.
- Chrome vanadium bit holder, correctly hardened, tempered and chrome plated.



AN040042/43 45° FLARING, DOUBLE FLARING & CUTTING TOOL SET

Includes heavy duty tube cutter, standard 45 flaring tool and double flaring adapters set in custom carrying case.
AN040042
 Heavy duty tube cutter for 1/8" to 1-1/8" tubing; standard 45 flaring tool flares 7 sizes : 3/16", 1/4", 5/16", 3/8", 7/16", 1/2" and 5/8" O.D. tubing; five double flaring adapters cover 3/16", 1/4", 5/16", 3/8" and 1/2" O.D.
AN040043
 Metric flaring, double flaring & cutting tool set flares seven metric sizes : 4mm, 4.75mm, 6mm, 8mm, 10mm, 12mm and 14mm O.D. tubing. Five double flaring adapters cover 4mm, 4.75mm, 6mm, 8mm and 10mm tubing.



AN040169 WHEEL HUB PULLER SET

- for wheel hubs, half shafts, brake drums, etc....
- This set with the 4.3KG slide hammer can remove wheel hubs, half shafts, brake drums, drive shafts directly in the car.
- A mechanical spindle can press out drive shaft.
- Suitable for VW, Audi, Alfa Romeo, Ford, Citroen, BMW, Mazda, Fiat, M-Benz, Seat, Opel, Peugeot, Renault, Skoda, Porsche, etc....
- Bolt size: M12*1.5
M14*1.5
- Spindle Standard: Inner Thread: 2-1/4"-14uns
Range: 90-130mm
Outside Diameter: 160mm

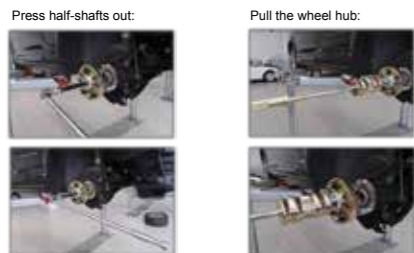

Press half-shafts out:

Pull the wheel hub:



AN040087 HONDA LOWER CONTROL ARM BUSHES REMOVER/ INSTALLER (HYDRAULIC DRIVE)

- Features:
- On car maintenance
 - For replacement of bushes on HONDA cars.
 - Easy to use. Save time and money.
 - Applicable : HONDA CR-V (before 2001) · CIVIC K6 (1992) · CIVIC K8 (JC)(1996) · CIVIC K2 (carburetor) · CIVIC K3 (injection)
 - General introduction for bush :
 - A flexible bush has an elastomeric element enclosed between an outer sleeve and a centre axis to ensure better road grip and stability. Makes driving more comfortable.



k6 lower control arm k8 lower control arm k10 & CR-V lower control arm



AG010138 1/2" IMPACT DRIVER W / 36MM 13 BITS

- The new grip can keep your hands away from potential danger while striking.



AG010140 MULTI - DOLLY (width: 37 mm)

- Auto body repairing D.I.Y & sheet metal working.
- Student crafts working.
- Personal working studio.
- Made from carbon steel by hot forging & precision.
- Heat - treatment.



AG010055 PROFESSIONAL IMPACT DRIVER

Chrome molybdenum.
 36L Phillips NO. 2, NO.3, 36L Slotted 8mm, 10mm.



AG010055A IMPACT DRIVER SET

- Chrome Vanadium steel
- Bits. Material : S2.
- Contents :
 4Bits x 36mm : PHILLIPS Ⓢ NO.2, NO.3
 SLOTTED Ⓢ 8mm, 10mm
 2Bits x 80mm : PHILLIPS Ⓢ NO.2, NO.3



M10110 PICK & FINISHING HAMMER (CROWNED FACE + ROUND POINT PICK)

- Crowned face.
- With hickory handle.



M10210B STRAIGHT PEIN & FINISHING HAMMER

- Crowned face.
- With hickory handle.



M10410B LIGHT SHRINKING HAMMER (FLAT FACE)

- Milled face.
- With hickory handle.



AG010030A 6PCS AUTO REPAIR TOOL SET

- CONTENTS :
- AG010030A-2 1 PC Double End Hand Dolly.
 - AG010030A-3 1 PC Drip Moulding, Spoon.
 - AG010030A-1 1 PC Curved Dolly.
 - AG010030A-4 1 PC Toe Dolly.
 - M10110 1 PC Pick & Finishing Hammer.
 - M10401B 1 PC Light Shrinking Hammer (Flat Face).



AG010037 RECTANGULAR MAGNETIC TRAY (SIZE : 240 X 140 MM)



AG010087 STEERING WHEEL PULLER

- Pulls steering wheels on most US and import cars.
- The floating swivel on the center screw prevents damage to the steering column.
- Zinc plated.
- 2 sets of bolts.



MF05S 5PCS 8" FILE SET

- 1PC: Flat File
- 1PC: Round File
- 1PC: Half-Round File
- 1PC: Square File
- 1PC: Triangular File

Contents:
A- Flat File
B- Round File
C- Half-Round File
D- Square File
E- Triangular File



AG010032 TELESCOPING INSPECTION MIRROR

Size : 32mm.



AG010033 TELESCOPING INSPECTION MIRROR

Size : 50 x 92mm



AG010034 MAGNETIC PICK-UP TOOL

Heavy duty pocket.
 Capacity : 3.5 Lbs. L : 580 mm.



AG010035 3 IN 1 LIGHTED MAGNETIC MIRROR

Attach 25 x 50mm swivel inspection mirror and magnetic riveter.
 Heavy duty.

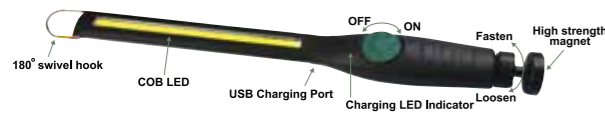

AG010207 15W COB LED WORKING LIGHT

- Lumen adjustable
- Brightness: 410 LM
- Highest illuminance: 935 LUX for projecting distance of 50 cm
- Half illuminance: 300 LUX for projecting distance of 50 cm
- Fully charged battery allows 2.5 hours for full brightness, or 10 hours for half illuminance
- With charging adaptor
- Features:
 1. Lumen tuning switch
 2. Rotatable base with powerful magnet
 3. Swivel hanging hook
 4. Built-in 2200mAh LI-Ion batter
 5. Long battery life. It can support the highest illuminance for around 2.5 hours and half illuminance about 10 hours.
 6. Short charge time: 3.5-4 hours Charging: red flash light/ blue light on/ yellow flash light
 7. USB charger & USB cable enclosed



Specifications:
 A. LED Max power: 15W LED COB light
 B. Li-ion Rechargeable battery: 3.7V 2200mAh
 C. Charger input: AC100~240V 50/60Hz
 D. Power output: 5.0V 1000mAh
 E. Charge time: 3.5-4 hours
 F. Battery life (active time): 2.5~10 hours
 G. Storage temperature: -20°C to 70°C
 H. Operation temperature: -5°C to 50°C
 I. Product Size: 375(L)x40(W)x30(H)mm



AG010039 160LB/IN² 270MM PROFESSIONAL TIRE PRESSURE GAUGE FOR GENERAL CAR



AG010041 200LB/IN² 380MM PROFESSIONAL TIRE PRESSURE GAUGE FOR GENERAL CAR



AG010047 380MM TIRE AIR CHUCK



AG010099 16" PUSH & FOLDABLE CROSS - HANDLE SOCKET WRENCH

- Mat Finish
- Socket Size : 17, 19, 21 mm, 1/2" DR. (11/16", 3/4", 13/16", 1/2" DR.)

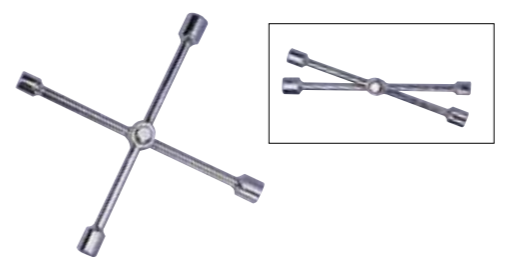

AG010101 14" PUSH & FOLDABLE CROSS - HANDLE SOCKET WRENCH

- Mat Finish
- Socket Size : 17, 19, 21, 23 mm (11/16"x3/4"x13/16"x7/8")



AG010169 2 WAY TRUCK WRENCH, CR-V 6140

- AG010169
- Size: 32X33MM, DIA: 1" X16"
- HRC38-45, CHREOME PLATED
- W/DIA. 3/4" X600MM BAR, CR-MO, HRC38-45, CHROME PLATED



AG010090A DIGITAL TIRE INFLATOR

- Feature:
- Body Gun: Zinc & TPR
 - Air Inlet: 1/4" Female (Air Inlet With 20 Mesh Screen)
 - Operating Pressure: 90 PSI
 - Air Flow 1.1 CFM At 100 PSI
- Function:
- Fill Air. (Inflation)
 - Release Air. (Deflating)
 - Gauge Pressure. (Measuring)
- Specification:
- Gauge :2-1/2" Rubber Shroud Protection
 - Large LCD Display For Easy Reading
 - Operation Temperature: -10°C~45°C
 - Pressure Gauge: PSI- Bar, Kg/cm² - Kpa
 - Measuring Range From 0-200 PSI (Accuracy: +/- 1%)
 - Supply Voltage: LED-9.0V
 - 360 Degree Hose Rotation & Clip Tip. (Hose 50cm)

• Proper Tire Pressure Improver
 Maximize Gas Mileage

• Automatic Switch ON Off ZERO
 • Automatic Shout Off After 180 Seconds of Non-Usage To Conserve Battery Life



AG010038AL PROFESSIONAL 3 FUNCTIONS TIRE GAUGE (L : 1600MM)



AG010042 HANDY TIRE GAUGE

- CORRECT TIRE PRESSURE :
1. INCREASES GAS MILEAGE
 2. INCREASES DRIVING SAFETY
 3. REDUCES TIRE WEAR
- FEATURES:
 EASY TO READ PORTABLE ANSI GRADE B ACCURACY SHOCK RESISTANT WITH RELEASE BUTTON

MERCEDES BENZ REPAIR TOOLS

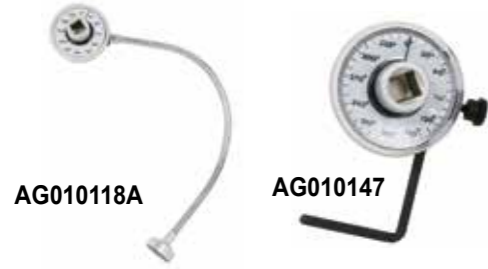

AG010147	TORQUE GAUGE
AG010118A	TORQUE ANGLE METER

Use with 1/2" DR. commonly used for tightening head bolts and other bolts where a torque angle is required.



FOR PASSENGER CAR & TRUCK

AG010119CS	2PCS MAGNETIC ADJUSTABLE CAMBER GAUGE
------------	--

- Accurate camber measuring tool for use after repairs or replacement of struts, wheel assemblies etc. for cars and trucks.
- Vials housed in a durable non-magnetic casing with a magnetic head that attaches firmly to rotors or spindles.
- Gauge can be preset at any angle 0° to 90° before making adjustment.
- Range: 5° positive to 5° negative in 1/2° increments.



AG010048	6PCS SCREW EXTRACTOR SET
----------	---------------------------------

- Made of Chrome Molybdenum.
- Size : 1/8", 1/4", 5/16", 7/16", 9/16", 3/4".

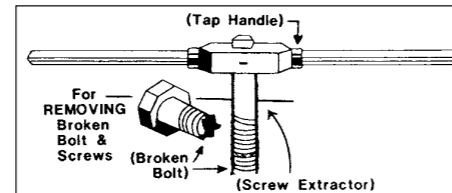

AG010049	5PCS SCREW EXTRACTOR SET
----------	---------------------------------

- Made of Chrome Molybdenum.
- Heat treated
- Quick & easy way to remove broken screws, pipes, bolts & studs.
- Drill size : 5/64"(2mm), 9/64"(3.5mm), 5/32"(4mm), 1/4"(6mm), 19/64"(7.5mm).

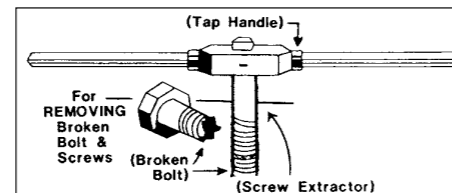

AG010217	MOBILE WORK CHAIR
----------	--------------------------

PRODUCT DIMENSIONS	350MM(L) X 260MM(W) X 240MM(H)
LOAD CAPACITY	150KG
MATERIAL	STEEL
	INCLUDING BOTTLE RACK





AE320030 SPRING COMPRESSOR FOR MERCEDES BENZ

- Types : 116/123/124/126/129/201/202/140 and 4-Matic includes.
- Advantage : Newly developed automatic 3-point safety interlock and automatic freewheel at end of stroke.



AE320031 BENZ BALL JOINT INSTALLER W123/126/220

- For pressing ball joint into steering knuckle.
- Application : W123/W126/W220



AI010026 BENZ (M111, M112) CRANKSHAFT PULLEY HOLDER

- Suit for BENZ M111, M112
- Break loose the crank shaft pulley/harmonic balancer bolt. Designed to properly secure the pulley from rotating during R&R of crank bolt. The 50mm hex head armature slips past the lightest of spaces and slides right into the center slot on the pulley. Then slide the long bar onto the receiving end of the armature and lock it into position with the securing bolt.



AI010030A ADJUSTABLE UNIVERSAL CRANKSHAFT PULLEY HOLDING TOOL

- Adjustable distance: P.C.D. 30mm~150mm
- Material: SCM440 (Forging)
- This tool is designed for holding the crankshaft only.
- Applicable: BENZ S600, M137, M112, M113, M271, M642, CEFIRO A32, A33, and Most kinds of engine



AI020112 BENZ SPARK PLUG SOCKET (Dr. 3/8" x 5/8' (16mm))

- Spark plug socket 5/8" (16 mm) with retaining spring and joint, 3/8" square drive, outer diameter 22mm, length 93mm.
- Applicable: M112, 113, 137, 155, 166, 271, 272, 273, 275, 902, 906.



AI020113 BENZ 7PCS NOZZLE INJECTOR PULLER FOR MERCEDES BENZ (SLIDE HAMER STYLE)

- For removing stubborn injectors on Mercedes Benz CDI engines and adapted tight common rail injectors without having to disassemble cylinder head.
- The puller is additionally supported by the steel ball on the valve cover which prevents the puller from tipping during the removal process. Applicable: Mercedes CDI engines OM 611.612.613

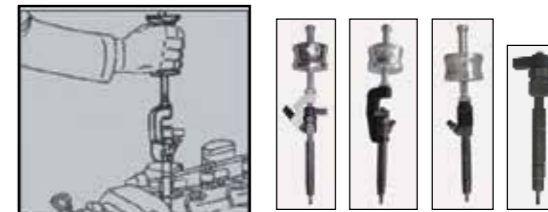

AI050071 BENZ & BMW FAN SERVICE WRENCH KIT

- The hardest material, S45C & heat treated.
- Shiny surface treatment, just like mirror.
- The best quality in the field.



AI050069 BENZ ENGINE OIL LEVEL GAUGE (STRAIGHT)

NO. / NAME	MATERIAL NO.	ENGINE TYPE	REMARK
AI050069 / BENZ ENGINE OIL LEVEL GAUGE (STRAIGHT)	120589062100	103,943,984/985,104,111,119,120,137,603,913/963/97,604,605,606,611,612,613,628,612,965	STRAIGHT
DESCRIPTION	dipstick for determining oil level and inspecting length of dipstick guide tube		



AI050084 BENZ ENGINE OIL LEVEL GAUGE (VOLUTE)

NO. / NAME	MATERIAL NO.	ENGINE TYPE	REMARK
AI050084 / BENZ ENGINE OIL LEVEL GAUGE (VOLUTE)	120589072100	112.113.646.647.648	VOLUTE
DESCRIPTION	measuring rod for measuring oil level and for checking length of oil pipe		



AI050070 MERCEDES-BENZ V6 ENGINE SPARK PLUG BOOT PULLER

- Special angle design with 17mm wrench to be a lever for removing and installing the wire easily.
- Applicable : BENZ V6 engine.





AI050083 BENZ (M111) OIL SEALING INSTALLER

- 210 589 00 15 00 drift punch for BENZ (M111) engine.
- Genuine stock no. : A111 016 0721 sealing ; no. : 210 5859 00 15 00 drift punch.
- The seals get crack because they expand when hot and shrink when cold.
- Easy and quick to install.



AI050085 MERCEDES-BENZ OIL FILTER WRENCH (74MM X 14 FLUTES)

- Dimensions : 74mm x 14 flutes x 1/2" drive.
- Applicable : all MERCEDES models, AUDI (A3), BMW (E36), CITROEN, FIAT, FORD, LANCIA, MAZDA, NISSAN, OPEL, PEUGEOT, PORSCHE, RENAULT, TOYOTA, VW(GOLF IV), FORD METROSTART... etc.
- Caution : please use 27mm socket with a wrench to manipulated the tool while the torque value is over 25 NM, otherwise the tool will risk being broken. The torque value limit is 25 NM if the tool operated with a wrench.



AI050137 BENZ ML, BMW OIL FILTER WRENCH

- DR. 1/2", 84 mm X 14 flutes
- 84mm Oil filter wrench with 14 points.
- Applicable: 2007 Dodge Sprinter, 2007 MERCEDES-BENZ E 320 and the 2007 Jeep Cherokee with the 3.0L V6 CRD (Common Rail Diesel) engines.



BMW 658 103 008 0
>PA66>GF35<7 521 353



M-BENZ ML 67 402 17 429
MANN+HUMMEL 1
>PA 66-GF 35<



AL010056 BENZ (M271) CRANKSHAFT HARMONIC BALANCER PULLEY HOLDER

- For removal and replacement of the crankshaft bolt.
- Applicable: Benz (M271)
- Genuine stock No.: A 271 030 00 03



AL010057 BENZ (642) CRANKSHAFT HUB LOCKING TOOL

No.	Chassis No	Model	Engine Type
1	W203. 020	C320 CDI	642. 91
2	W203. 220	C320 CDI	642. 91
3	W209. 320	CLK320 CDI	642. 91
4	W209. 420	CLK321 CDI Cabrio	642. 91
5	W219. 322	CLS320 CD	642. 92
6	W211. 220	E280 CDI	642. 92
7	W211. 020	E280 CDI	642. 92
8	W211. 620	E280 CDI	642. 92
9	W211. 022	E320 CDI	642. 92
10	W211. 222	E320 CDI	642. 92
11	W211. 024	E320 CDI BLUETEC	642. 92
12	W211. 084	E280 CDI 4 MATIC	642. 921
13	W211. 284	E280 CDI 4 MATIC	642. 921
14	W211. 089	E320 CDI 4 MATIC	642. 921
15	W211. 289	E320 CDI 4 MATIC	642. 921
16	W204. 022	C320 CDI	642. 96
17	W204. 089	C320 CDI 4MATIC	642. 961
18	W204. 289	C320 CDI 4MATIC	642. 961



AL010058 BENZ AIR CONDITIONING COMPRESSOR PULLEY HOLDING TOOL

- Counter holder for fixing in place and unfastening the belt pulley on the air condition compressor..
- Applicable : Benz Engine 112.113.272.273



AL010061 BENZ (M112/M113/M137) CRANKSHAFT HARMONIC BALANCER PULLEY HOLDER

- For removal and replacement of the crankshaft bolt, M112, M113 & M137, as found on E320, E430... etc.



AL010076 BENZ TIMING LOCKING TOOL SET

- Suitable for a wide range of Benz, included in Petrol and Diesel engines.
- The whole set includes:
- AI010099 BENZ FLYWHEEL RETAINING LOCK TOOL
Applicable: BENZ ENGINE MODEL 112, 113, 137, 155, 156, 272/979, 273, 629, 642/992
Genuine no.: 112 589 03 40 00
- AI010118 BENZ FLYWHEEL LOCKING TOOL
Applicable: BENZ ENGINE MODEL 102, 103, 104, 111, 601, 602.91/93/94/96/983, 603.91/93/96/97, 604, 605, 606, 611, 612/965/966, 613
Genuine no.: 601 589 02 40 00
- AL010076-1 BENZ CAMSHAFT LOCKING PIN
Applicable: BENZ ENGINE MODEL 111, 119, 604, 605, 606, 611/980, 612, 613, 628, 629, 640, 642/922, 612.965/966, 646, 647, 648
Genuine no.: 111 589 03 15 00
- N.M.: 1.26



AL010016 BENZ 722.6 TRANSMISSION OIL LEVEL GAUGE

- Genuine stock no. : 140 589 15 21 00.
- The tool is designed for checking ATF level.
- Applicable : MERCEDES models 1997 and newer with 722.6 transmission.



AL010016A BENZ 722.7 TRANSMISSION OIL LEVEL GAUGE

- The tool is designed to measure the oil level of transmission.
- Full length : 920mm
- Applicable : transmission type 722.7, 7.16.5



AL010062 BENZ TRANSMISSION OVERFLOW PIPE REMOVER

- Drift for unclipping the overflow pipe in the oil pan when draining the oil.
- Applicable: BENZ 722.9 model transmission.



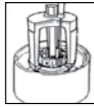

AN010119 BENZ ASSEMBLY FIXTURE

- Sleeve for installing reverse gear piston in front cover.
- Assembly device for brake band piston B1.
- Application : all MERCEDES models.
- Assembly fixture for circlip on spring retainer of clutch K1 and K2.

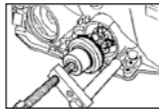

AN010120 BENZ ASSEMBLY DEVICE

- For brake band piston B1.
- Application : All MERCEDES models 722.1, 722.3, 722.4, 722.5

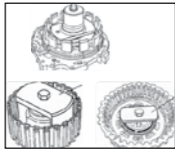

AN010123 BENZ SLEEVE, ASSEMBLY DEVICE & ASSEMBLY FIXTURE

- Genuine stock no. : 140 589 13 43 00.
- Sleeve for installing reverse gear piston in front cover.
- Assembly fixture for circlip on spring retainer of clutch k1 and k2.
- Applicable : transmission 722.6.
- NW : 5.2kgs GW : 5.4kgs
- Assembly tool; B1/2, K1/2 to compress clutch packs and allow installation of retaining ring (722.6).

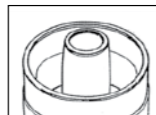

AN010124 BENZ TRANSMISSION SEAL ASSEMBLY SLEEVE

1	Transmission measure tool (Ruler Type)
2	Transmission measure tool (Plate)
3	Piston oil seal installer
4	Ki clutch
5	Transmission O-ring sleeve



AN010223 PROFESSIONAL WHEEL BEARING TOOL SET FOR MERCEDES

- Tool set for Mercedes set for e.g. 190 series (W201), A-Class (W168, W169), B-Class (W245), W124, C-Class (W202, W203), E-Class (W210), M-Class (W163, W164), S-Class (W140), V-Class (W639).
- This tool can safe, quick and professional replacement and removal of wheel bearing.
- minimum working effort – high time saving
- simple and safe handling

CONTENTS:

AN010223-M.Benz	Description
AN010223-501	Clamping nut
AN010223-502	Pull spindle
AN010223-401	Bearing cover
AN010223-402	Housing
AN010223-402B	Housing
AN010223-405	Centring ring Ø80
AN010223-366	Pressure ring Ø66
AN010223-370	Pressure ring Ø70
AN010223-373	Pressure ring Ø73
AN010223-375	Pressure ring Ø75
AN010223-379	Pressure ring Ø79
AN010223-383	Pressure ring Ø83
AN010223-384	Pressure ring Ø84
AN010223-385	Pressure ring Ø85
AN010223-387	Pressure ring Ø87
AN010223-388	Pressure ring Ø88
AN010223-390	Pressure ring Ø90
AN010223-393	Pressure ring Ø93
AN010223-242	Centring ring Ø42
AN010223-245	Centring ring Ø45
AN010223-249	Centring ring Ø49
AN010223-250	Centring ring Ø50
AN010223-254	Centring ring Ø54
AN010223-260	Centring ring Ø60
AN010223-395	Centring ring
AN010223-101	Retainer adaptor for clamping nut and pressure spindle with O-ring
AN010223-102	Retainer adaptor for mecanical spindle

Operation example:Disassemble Wheel Bearing

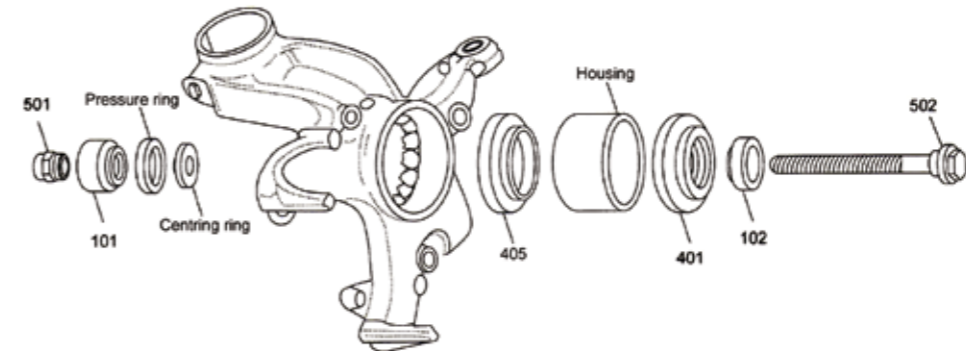

Operation example:Assemble Wheel Bearing

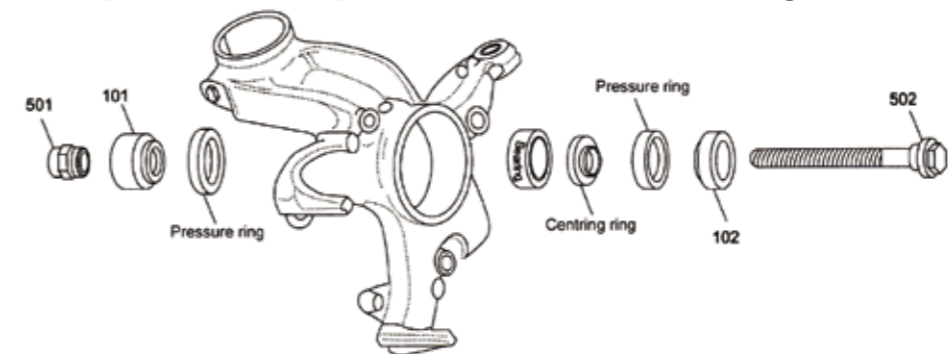



AN010182 BENZ (W220/W211/W230) BALL-JOINT REMOVER/INSTALLER

- On car maintenance.
- Special design to remove & install the ball joint, without removing any parts.
- Application: BENZ W220/W211/W230.



AN010213 BENZ TRANSMISSION GAER LEVER RUBBER INSTALLER

- This pliers installs the nylon bushing used on all models of Mercedes BENZ automatic transmissions, and some Ford, BMW, VW, AUDI and many other makes using ZF transmissions.
- This tool easily and safely pushes tough nylon bushings into place on the shift shaft. Works on several different bushing sizes.
- Applicable: BENZ W124/W126/W140/W201/W202/W210...etc.



AN040069 BENZ (W211/W220/W203) SUB-FRAME BUSH REMOVER / INSTALLER



AN040074 BENZ AXLES WHEEL BEARING EXTRACTOR / INSTALLER

- A great tool used to replace front wheel bearings without removing the steering knuckle & strut assembly.
- As the spindle assembly isn't removed, there is no need to align front end after the job is done, saving a lot of time.
- Applicable : MERCEDES-BENZ, BMW, TOYOTA, VW, MARCH, FORD, VOLVO...etc.



AG010204 1/2" DR. SPECIAL WHEEL LUG SOCKET 17MM X 88MM(L.)

- Material : CR-V with Manganese phosphated
- MS17 specially designed to loosen and tighten the new special wheel bolts found on Mercedes vehicles (17mm waf).
- Suitable for Mercedes M-class (W166), CL500(W216), S-Class (W221) and Maybach.

BMW REPAIR TOOLS





AI010084 BMW (M62) VANOS CAMSHAFT TOOLING

- Includes: AI010075 BMW V8(M60/M62) CAMSHAFT LOCKING FIXTURE
AI010084B BMW(M62) VANOS CAMSHAFT TIMING TOOL
AI010084C BMW(M62) VANOS TIMING HOOK
AI010084D BMW(M62/M54) VANOS ELECTROMAGNETIC VALVE
AI010084E BMW(M62) VANOS TENSIDNING BRACKET



AI010115 DIESEL INJECTION PUMP PULLER (BMW)

- THIS TOOL IS SPECIFICALLY DESIGNED FOR HOLDING THE SPROCKET / CHAIN IN PLACE WHEN DISASSEMBLING THE VP44 INJECTION PUMP AND HIGH PRESSURE PUMP.
- COMMON RAIL FITTED TO BMW ENGINES:
318D/COMPACT(E46) 530D(E39)
320D/TD COMPACT(46) 530D(E60/E61)
330D(E46) 535D(E60/E61)
525D(E39) 730D(E38)
525D(E60/E61) X5 3.0D(E53)

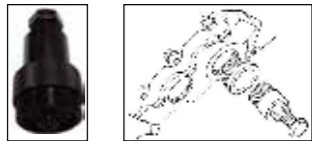

AI020068 BMW CAMSHAFT ALIGNMENT TOOL KIT

- BMW Engine models M42 & M50 : includes 2 blocks swivel lock plate & locking pin for setting camshaft timing.
- Engine models M40 & M70 : includes plate & locking pin for setting camshaft timing.
- BMW Engine models M60 & M62 : includes 2 blocks swivel lock plate & locking pin for setting camshaft timing.



AI020075 BMW (M60 / M62) CAMSHAFT ALIGNMENT TOOL

- Includes : 2 blocks swivel lock plate & locking pin for setting camshaft timing.
- Applicable : BMW engine models M60 & M62.
- NW : 4.1kgs



AI020076 BMW (M42 / M50) CAMSHAFT ALIGNMENT TOOL

- Includes : 2 blocks swivel lock plate & locking pin for setting camshaft timing.
- Applicable : BMW engine models M42 & M50.
- NW : 2.2kgs



AI020077 BMW (M40 / M70) CAMSHAFT ALIGNMENT TOOL

- Include : plate & locking pin for setting camshaft timing.
- Applicable : BMW engine models M40 & M70.
- NW : 1.08kgs GW : 1.2kgs



AI040061 BMW (N40/N42/N45/N45T/N46/N46T/N52/N53/N54) CRANKSHAFT FRONT OIL SEAL REMOVAL / INSTALL KIT

- Used to remover/install the front crankshaft seal.
- Application: BMW (N40/N42/N45/N45T/N46/N46T/N52/N53/N54)
- Genuine No.: BMW 119 220&119 230

Removal



INSTALL



AI050143 BMW(N40/N42/N45/N46/N52)OIL FILTER WRENCH (DR.1/2", 16 POINTS, 86MM)

- DR.1/2", 16 points, 86mm
- Applicable: BMW(316i, 318iAB, 01...etc.)most of recent VOLVO models (S40, S70, S80...etc.)
- Caution: Please use 27mm socket with a wrench to manipulate the tool when the torque is over 25 Nm, otherwise the tool will risk being broken. The torque value limit is 25 Nm if the tool is operated with a wrench.



AI050081 BMW (E31/E38/E39) WIPER LINKAGE ASSEMBLY REMOVAL/INSTALLATION SOCKET BIT (T80)

- Used to remove and install BMW (E31, E38, and E39) wiper linkage assembly.
- Used in conjunction with AI050082.
- Applicable : E12, E21, E23, E24, E28, E30, E30/C, WAGON E30, E31, E32, E32/3, E34, WAGON E34, E36, E36/2, E36/3, E36/5, E36/7, E36/C, WAGON E36, E38, E38/3, E39, E39PL, WAGON E39, E46, E46/16, E46/2, E46/3, E46/5, E46/C, E52, E53, E60, E65, E66, E67, E85, RR1...ETC.
- Requirement windshield wiper arm removed. T80 (1/2" square drive expert draper tx star impact socket bit).



AI010025 BMW (N42/N46) CAMSHAFT ALIGNMENT TOOL

- This tool is a gauge for fixing the camshaft in TDC position used to dismantle and assemble intake and exhaust camshaft.
- Applicable : BMW N42, N46.





AL010020K BMW (M52TU/M54/M56) TIMING TOOL KIT

- This kit includes AL010020A/B/C/D/F

AL010020A BMW M50-TU (M52/M54/M56) DOUBLE VANOS SETUP BRACKET

- M52TU engine(1999-2000 323i, 328i, 528i/1999-2002 Z3).
- M54 engine (2001-2005 325i, 330i, 525i, 530i, X5 3.0i/2001-2002 Z3 / 2003-2004 Z4 / 2004-2005 X3).

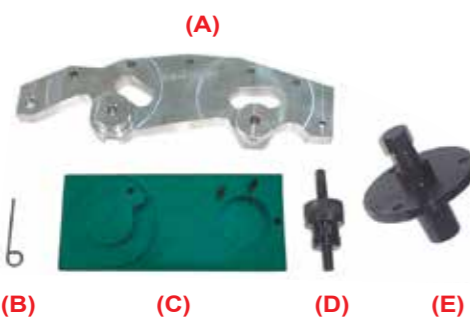

AL010020B SECONDARY CHAIN TENSIONER LOCKING PIN

- Locks chain tensioner during timing.
- Model: M50, M52

AL010020C SECONDARY SPROCKET TOOL

- Application : M52TU, M54, M56



AL010020D PRIMARY CHAIN TENSIONER TOOL

- Application : M52, M52TU, M54, M56



AL010020E PULLER FOR CRANKSHAFT HUB

- Removes stuck vibration damper hub in conjunction with



AL010020F VANOS COMPRESSED AIR FITTING (U.S. STANDARD)

- Optional Accessory
- Fitting allows for functional testing of VANOS adjusting unit. Use to pressurize the single and double VANOS unit when checking or removing and replacing.
- Application : M50, M52, M52TU, M54, M56, N62



AL010027 BMW (N62/N73) CAMSHAFT ALIGNMENT TOOL

- AL010027-1 inlet camshaft gauge (genuine stock no. : 11 9 461). AL010027-3 bracket with bolt (genuine stock no. : 11 9 462).
- AL010027-2 exhaust camshaft gauge (genuine stock no. : 11 9 463).
- AL010027-4 BMW(N40, N42, N62, N73)camshaft alignment pin.
- Used to lock the camshaft on TDC position.
- Applicable : BMW N62, M73 engine.
- Accurate, easy to use, unique tool for maintenance.
- Best choice for engine overhaul on BMW (N62, N73) camshaft.



AL010030 BMW (M52/M54/M56) CRANKSHAFT HUB LOCKING TOOL

- Modes: M52TU, M54, M56



AL010036A BMW (N51/N52) TIMING TOOLS & PLUG MANDREL

- For locking flywheel in TDC position on BMW N51, N52, N52K, N53, N54.
- Turns crankshaft to TDC position while central bolt moves.
- Put AL010036A-3 into calibrate hole (arrow ahead) and fixed crankshaft. Attention:
- 1. In the vehicle which carry special equipment SA205 (Automatic Transmission), there is a big hole make use of TDC position nearby calibrate hole.
- 2. When AL010036A-3 stayed in calibrate hole and locked flywheel, it is impossible to move engine through central bolt.



AL010063 BMW(M47) DIESEL ENGINE CAMSHAFT ALIGNMENT TOOL

- Camshaft setting and flywheel locking tools to cover the latest range of BMW 2.0 and 3.0 litre common rail diesel engines used in BMW and other manufacturer's models.
- Applicable: BMW 2.0 (M47) and 3.0 (M57) Diesel Engines in BMW 3, 5 & 7 Series, X5, Land Rover Freelander, Range Rover, Rover 75



AL010077 BMW (N62/N73) TIMING TOOLS

- Includes AL010077-1, AL010077-2, AL010077-3, AL010077-4, AL010077-5, AL010077-6, AL010077-7, AL010077-8, AL010077-9, AL010077-10 and AL010077-11



AL010078 BMW (N40/N45/N45T) PETROL ENGINE TWIN CAMSHAFT SETTING / LOCKING TOOL SET

- Suitable for timing 1.6 Litre BMW N40, N45 and N45T chain driven petrol engines with Vanos units on the inlet and exhaust camshafts.
- Engine Codes: N40, N45, N45T(B16)
- BMW: 116 1.6i E81/E87(03-09)
- 316 1.6i E46/E90(01-08)
- 316 1.6Ci E46/E90(01-06)
- 316 1.6ti E46(01-05)

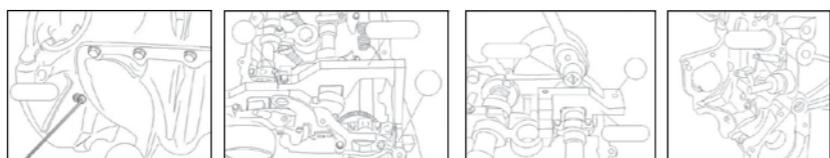

AL010079 BMW MINI COOPER (N12) TIMING TOOL SET

- Applicable: BMW MINI COOPER(N12) 2007 R55
- BMW MINI COOPER(N12) 2006~2007 R56

AL010102 BMW (N47/N47S) DIESEL ENGINE TIMING KIT

- For timing the BMW N47/N47S 2.0 twin camshaft diesel chain drive engines, fitted in the 1 Series, 3 Series, 5 Series and X3.
- Applications: BMW; 1 Series, 118d (E81/E87)(06-09), 120d (E81/E82/E87)(06-09), 123d (E81/E82/E87)(07-09), 3 Series, 318d (E90/E91)(07-09), 320d (E90/E91/E92)(05-09) 5 Series, 520d (E60/E61)(06-08), X3, 2.0d (E83)(07-09)
- Engine Codes: N47, N47S(2007-2010)

Parts No.	Description	OEM No.
AL010102-1	Flywheel Plate Timing Pin	115 320
AL010102-2	Camshaft Alignment Tool	118 760
AL010102-3	Crankshaft Pulley Turning Tool	116 480
AL010102-4	High Pressure Pump Sprocket Removal Tool	118 740
AL010102-5	Tensioner Locking Pins X 2	113 340

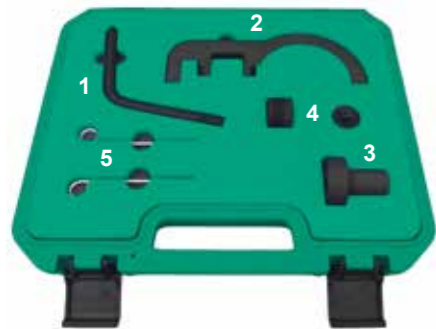

AL010103 BMW MINI COOPER (N12/N14) TIMING TOOL SET

- Positioned crankshaft by AL010103-4 when rotating crankshaft in central bolt. Note: Do not remove AL010103-4 while maintenance.
- When repairing exhausted camshaft, install AL010103-1 on it and fixed tool by AL010103-3.
- Install AL010103-2 to cylinder head cover fastened by AL010103-3-1. Put AL010103-1 on intake camshaft, and fixed tool by AL010103-3.
- Application: BMW MINI COOPER (N12/N14) 2007 R55
- BMW MINI COOPER (N12/N14) 2006~2007 R56



AL010025A BMW (N42/N46) PETROL TIMING TOOLS KIT

- Using with AL010025C. This kit includes AL010025-1, AL010025-2, AL010025-3, AL010025-4, AL010025-5, AL010025-6, AL010077-5.
- Timing, checking and adjusting the twin camshaft on petrol engine.
- Removing, installing and aligning of vanos unit.
- Applicable: BMW:
- E87(1 Series): 118i/120i N46 engine
- E46(3 Series): 316i/316Ti/318i/318Ti/(01-)N42/N46 engine
- E90/E91: 318i/320i N46 engine
- E85: Z4, 2.0L-N46 engine
- E83 N46 engine

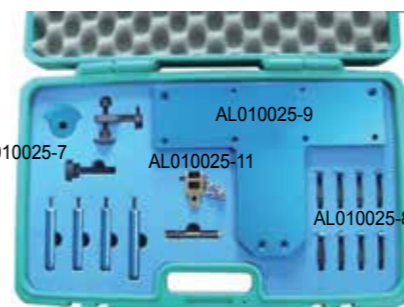
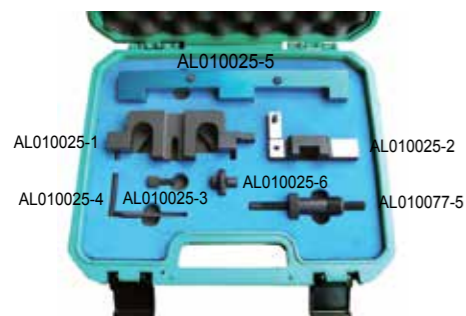

AL010025C BMW (N42/N46) CAMSHAFT CARRIER BRACKET REMOVAL / INSTALLTION KIT

- Using with AL010025A. This kit includes AL010025-7, AL010025-8, AL010025-9, AL010025-11.
- Installation, removal and timing of variable camshaft timing unit/camshafts.
- Checking and adjustment of camshaft timing.
- Applicable: BMW:
- E87(1 Series): 118i/120i N46 engine
- E46(3 Series): 316i/316Ti/318i/318Ti (01-)N42/N46 engine
- E90/E91: 318i/320i N46 engine
- E85: Z4, 2.0L-N46 engine
- E83 N46 engine

AL010036N BMW (N51/N52/N52K/N53/N54) TIMING TOOLS

- This kit includes AL010036A-1, AL010036A-2, AL010036A-3, AL010036B and AL010077-5.
- Applicable: models:
- 128i, E82(07-08), 130i, E81/E87(05-08), 135iS, E82(07-08), 323i, E90/91/92/93(04-08), 325i/xi, E90/91/92/93(04-08), 328i/xi, E90/91/92/93(04-08), 330i/xi, E90/91/92/93(04-08), 335i/xi, E90/91/92/93(04-08), 523i/Li/xi, E60/61(04-08), 525i/Li/xi, E60/61(04-08), 528i/Li/xi, E60/61(06-08), 530i/Li/xi, E60/61(05-08), 535i/xi, E60/61(06-08), 630i, E63/64(04-08), 730i/Li, E65/66(04-08), X3 2.5/3.0, E83(06-08), X5 3.0, E70(06-08), Z4 2.5/3.0, E85/86(05-08)
- Engines: N51/N52/N52K Valvetronic, Direct Injection, Non-Valvetronic N53/N54

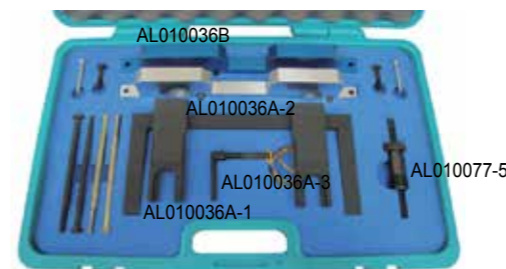

AL010085 BMW (N42 · N46) CAMSHAFT ALIGNMENT TOOL

- Special design to fix the camshaft in TDC engine.
- Applicable : BMW N42 · N46



AL010080 BMW (N43) TIMING TOOL KIT

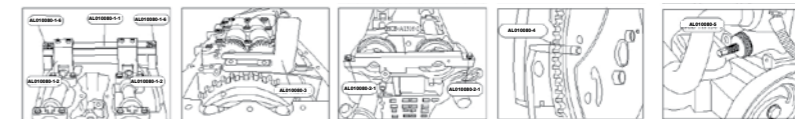

**VOLKSWAGEN & AUDI
REPAIR TOOLS**



AL010025-5 BMW(N42 · N46) INTAKE / EXHAUST CAMSHAFT GAUGE

- For disassembling the camshaft or realigning the camshaft.
- Applicable : BMW (N42/N46)



AL010099 ENGINE TIMING TOOL SET FOR PROFESSIONAL ENGINE REPAIR FOR BMW DIESEL ENGINES M41/M51/M47 TU M47 TU/T2, M57/TU/ T2:2.01/3.01; YEAR1998-2008

- Installation and removal of the camshaft / hydraulic chain tensioner
- Checking and adjustment of camshaft timing
- Easily accessible operating instructions including cross references to original part numbers
- Spare parts optionally available
- Clear arrangement of tools in high-quality plastic case with soft foam insert

E36: 318tds/318tds Compact Bj. 94-00/ 325td/ tds Bj.91-99	E38/E65/E66: 730d
E34/E39: 525td/tds Bj. 91-03	E83: X3, 2.01d/ 3.01d
E38: 725tds Bj. 91-03 M47/M47TU/T2/M57TU/T2	E53/E70: X5, 3.01d
E87: 118d/ 120d	E90/E91: 316i, 316ti, 318ci, 318ti, 320i
E46: 318d/ 318td Compact/ 320td Compact/ 320d/ 330d	Land Rover: 2.5DT Bj. 1994-2002
E39: 520d/ 525d/ 530d	Land Rover: 3.0TD6 Bj. 2002-2006
E60/E61: 525d/ 530d/ 535d	Freelander. 2.0TD4 Bj. 2002-2006
E63: 635d	



AN050014 VW, BMW SOCKET (1/2"DR. , 12 POINT, 21MM)

- For installing model and removing the front strut units on VW-GOLF II and JETTA since model 1987, GOLF III and VENTO since model 1993, PASSAT since 1988 and some Porsche.
- For loosening shock absorbers bolt on BMW E38, E39, E46, E52, E53, E60, E61, E63, E64, E65, E66, E83, E85, E86, E87, E90, E91, E92, E93, R50, R52, R53
- Drive 12.5=1/2"
- Chrome- Vanadium
- Surface chrome- plated
- N.W.: 0.142 KGS



AE310178 BMW BALL JOINT PULLER (27&31MM)

- For quick and easy separate ball joint connections.
- AE310178-6 is particularly useful for control arms from steering knuckle. Special for E53, E83
- Applicable: BMW E38, E39, E52, E53, E60, E61, E70, E83, E90, E91, E92, R50, R52, R53, RR1, RR2, X5, W211





AL010028 VW DIESEL 2400CC. CAMSHAFT ALIGNMENT TOOL

- Locks the camshaft in the proper position to allow the drive belt to be removed or replaced.
- NW. : 1.1kgs GW. : 1.2kgs



AL010029 VW, AUDI PETROL 1.4 & 16V TWIN CAMSHAFT ALIGNMENT TOOL SET

- It is convenient for working and fixing the timing on camshaft.
- Applicable : AUDI A2 (00-04).
seat : AROSA, IBIZA, CORDOBA, TOLEDO, LEON, INCA (99-04).
SKODA : FABIA, OCTAVIA (99-04).
VW : LUPO, POLO / CLASSIC, BEETLE, GOLF, BORA, CADDY.



AL010033 VW, AUDI V6 CAMSHAFT SETTING PLATE

- Used to hold both camshafts at TDC position when replacing timing belt.
- Applicable : AUDI : A4, A6, A8, S4, allroad (95-04).
VW : Passat (96-04) with codes : ack, aga, agb, aig, alf, alg, alw, aml, amm, amx, apr, aps, apz, aqd, are, arj, asm, bdv, bes.



AL010039 CAMSHAFT ALIGNMENT TOOL

- This tool is used for holding both camshafts at the TDC position when replacing the timing belt. Used Audi & VW models with V8 motors with 5 valves per cylinder (except S4)



AL010066 VW & AUDI CAM CHAIN TENSIONER RETAINER

- Use to hold the chain and tensioner in position when assembly and disassembly.
- Applicable : AUDI-AHA,AMB,AMU,APB,ART,ATC,ATQ,AWM,AWN,AWP,BBD,BCY,BEA,BEL,BFM,VW-AHA,APH,ATQ,AUG,AWM,AWP,AWV,BKF,BNU 1998-2006.

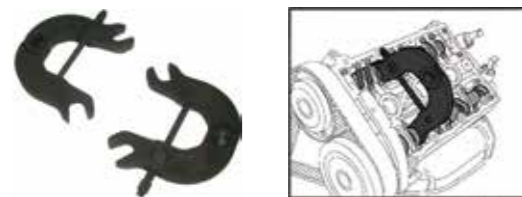

AL010067 AUDI CAMSHAFT ADJUSTMENT GAUGE SET (2000-2004) (3.0L V6)

- Use to lock and hold camshafts when adjusting the left and right camshafts.
- Applicable: AUDI A4 (2002-2005), AUDI A6 (2002-2004)
- Applicable Engine: AVK, AUDI 3.0L, V6 5V



AL010067B AUDI/VW CAM ALIGNMENT TOOLS SET

- Applications:
- Used to align and hold camshaft
 - Applicable: VW polo Diesel, Audi 100 since 1991, Audi A6 with engine Z15L TDI
 - Holds crankshaft at TDI (top dead center) when removing and installing toothed timing belt and flywheel / drive plate.
 - To lock the camshafts for installation of drive belt
 - Tensioner retaining pins: To lock the automatic tensioner when changing the timing belt.
- Extra applicable: Alfa Romeo , Fiat , Citroen , Peugeot , Renault , Volkswagen
- A.Crankshaft locking pin
 - B.Camshaft adjusting tool: 3/8" DR Nut.
 - C.Tensioner retaining pins / 0.8mm,1.2mm,1.4mm,1.5mm,1.8mm,1.9mm
 - D.Camshaft locking tools (Pair)



AL010054 ENGINE TIMING TOOLS - VW & AUDI

- THIS NEW KIT OF TWELVE TOOLS IS REQUIRED FOR PETROL & DIESEL ENGINE SERVICE.
- INCLUDING TIMING BELT REPLACEMENT ON RECENT MODELS AND ALSO OLDER 1.9D MODELS FROM 1976.
- MODELS: AUDI A4, A6, A8, A11 YOAD (97-04), VW PASSAT (98-04).



AL010086 TIMING TOOL SET FOR VW AND AUDI FSI 2.0 LITRES / TURBO

- With camshaft tools · chain tensioner retainer, locking pins and tensioner bolt
- For 2.0 FSI petrol engines since 2003 in :
AUDI A3 2.0 FSI and FSI SOHC engines codes AWA · BHD · BMB
VW GOLF 2.0 FSI and 2.0 FSI SOHC and Touran
2.0 FSI SOHC engine codes AWA · AXW
OEM CODE DESCRIPTION
- T10250 CAMSHAFT CLAMP
- T10020 PIN WRENCH
- T10092 TENSIONING BOLT
- T40011 LOCKING PIN
- T10060A LOCKING PIN
- 3366 CHAIN TENSIONER RETAINER



AI010069 VW CRANKSHAFT LOCKING SET

- Used to retain and lock the camshaft timing when replacing the timing belt or servicing engine parts.
- Suits VOLKSWAGEN BORA, GOLF, LUPO and POLO TDI'S.



AI010069A CRANKSHAFT LOCKING TOOL

- For 2.0 Liter VOLKSWAGEN AUDI Engines-non Bored Out Engines.



AI010100B VW AUDI TIMING PULLEY PULLER

- DIA. SPREAD:50-95MM



AI020107 DIESEL FUEL PUMP TIMING SET

- Special designed to reset the timing position on diesel engine with fuel pump.
- Applicable: ALFA ROMEO, AUDI, BMW, FIAT, FORD, ISUZU, IVECO, LANCIA, LAND ROVER, MITSUBISHI, NISSAN, RENAULT, ROVER, and VW. etc...



AI020134 VW AUDI DIESEL INJECTOR REMOVER (TDI)

- Specially designed for removing the seized diesel injector from VAG TDi engines.
- Always allow to cool down the engine before using the tool.
- Special two jaws design to fix the injector and pull out with slide hammer.
- Applicable: VW, AUDI TDi engine code: ALH/AHU/1Z



AI020127 VW AUDI DIESEL INJECTORS REMOVER (TDI)

- Special two jaws design to fix the injector and pull out with slide hammer
- Applicable: VW, AUDI [TDI] engine.



AI040039 VW, AUDI IGNITION COILS PULLER

- To take and plug-on of the ignition coil off with power-output stage at VW, AUDI fuel injection engines.
- The front hook removes ignition coil off well from damage it self.
- Application: VW, BORA, GOLF, NEW BETLE, PASSAT, POLO, TOURAN 1.4/ 1.6L, LUPO 4-ZYL, FSI, PHAETON and T4, BBY. BKY1.4



AI040040 VW, AUDI IGNITION COILS PULLER

- To take and plug-on of the ignition coil off with power-output stage at VW, AUDI fuel injection engines.
- The front hook removes ignition coil off well from damage it self.
- Application: VW, BORA, GOLF, PASSAT, SHARAN, TOURAN, R32, PHAETON and T5, V5 2.3, V6 3.2



AI040041 VW, AUDI IGNITION COILS PULLER

- To take and plug-on of the ignition coil off with power-output stage at VW, AUDI fuel injection engines.
- The front hook removes ignition coil off well from damage it self.
- Application: VW 8 and 12 cylinder engines e.g. Phaeton, B5 1.8T, GTI. FSI 2.0



AI050067 VW, AUDI WATER PUMP PULLEY LOCKING WRENCH

- Safe locking of the water-pump pulley. Easily loosening the stubborn bolts on the water-pump pulley.
- Over length : 298mm, width : 65mm
- Applicable : VW, AUDI.



AI050090 TIMING ADJUSTABLE TOOL

- Use for :
- VW : LUPO, POLO/CLASSIC, GOLF, BORA & CADDY.
 - ADUI : A2



AI050105 WINDSHIELD WIPER PULLER

The Wiper Puller is specially designed for use to remove the rear wiper arms with water jets included in the spindle of motorcars. For use with SKODA, AUDI, SEAT, VW and other.

- Always loosen the nut from the wiper arm BUT never totally remove the nut.
- Removal of the nut may cause damage to the plastic arm of metal ferrule (where fitted).
- Locate the hole of the bolt over the spindle.
- Place the jaws of the tool under the wiper arm at the base of the spindle.
- Tighten with fingers first.
- Use 3/8" drive ratchet to 'dis-engage' arm from spindle.
- Lubrication maybe required.

VOLVO REPAIR TOOLS

**AL010110 LAND ROVER , JAGUAR, VOLVO(T6)
CAMSHAFT ALIGNMENT TOOL KIT**

- Special designed to align the engine camshaft and crankshaft position, and correct into the side cover.
- Application: Land Rover , Jaguar, VOLVO S80, XC90, XC60, XC70 3.0T, 3.2 (T6 Engine) since 2007

Parts No.	Description	OEM no.	Q'ty
AL010110-1	CRANKSHAFT WRENCH	9997257	1
AL010110-2	CAMSHAFT ALIGNMENT TOOL	9997261	1
AL010110-3	COVER INSTALLER/ REMOVER	9997263	1
AL010110-4	COVER INSTALLER/ REMOVER	9997264	1
AL010110-5	1/2" Dr. T60 STAR SOCKET	9997272	1
AL010110-6	MOUNTING	9997271	1
AL010110-7	ENGINE COVER ALIGNMENT TOOL	9997266	1
AL010110-8	ENGINE COVER ALIGNMENT TOOL	9997267	1



Heavy Duty Truck SERVICE TOOLS



AN040056 BPW TRUCK SOCKET TOOL (REAR WHEEL)

- The rear axles cover extractor socket
- Size : 120mm, octagon.
- Applicable : BPW-16T

JONNESWAY



AN040062 MAN (422,403), BENZ TRUCK DIESEL INJECTION VALVE SOCKET

Inner:ø22mm
Outer:ø28mm
The tool to remove and install diesel injection valve.
Application : MAN (422.403) BENZ Truck, SCANIA



SAFETY INSTRUCTION

Jonnesway pneumatic tools aim to provide customer the industrial safety, excellent performance, vibration deduction and friendly services.

The following safety instructions cover all possible or conceivable conditions which may occur during operations. Before operating, please read the following safety instructions to avoid unnecessary hazards.

A. Wearing Protection Masks

Always wearing protection masks (such as safety goggle, ear mu and hand glove...etc) while operation pneumatic tools to avoid damage.

B. Avoid Damage Caused from Vibration or Repetitive Work Motion

Prolonged exposure to vibration or repetitive work motion may be harmful. If you feel tingling, numbness, discomfort or pain, please stop using tool and consult to a physician. Employees and operators should always follow the instructions as below:

1. Use hand grips with proper control to save energy while operating.
2. Keep your wrists as straight as possible.
3. Avoid very repetitive movements of the hands and wrists.
4. Keep hands and body warm and dry.
5. Avoid continuous vibration exposure.

C. Avoid Hazards from Compressed Air

Air under pressure can cause injury. Please aware the safety instructions as follows to ensure you a safer working environment.

1. Do not point the air hose at yourself or others. Always direct exhaust air away from yourself and others in the work area.
2. Before operating, always check for damaged or loose hoses and fittings.
3. Always disconnect the tool with air compressor when not in use, before changing accessories, setting the torque. Or when making repairs.
4. Always keep air pressure in proper rate. Exceeding rated air pressure may shorten tool's life.
5. Do not connect air tools with electric power sources.
6. When using universal twist couplings, lock pins should always be installed to avoid accidental hose disconnection.

D. Avoid Additional Hazards

1. Slip, Trip, Fall is the major cause of injury and death! Beware of excess hose/cord left on the walking or work surface.
2. Operators and maintenance personnel must be physically fit to perform job tasks, and handle the bulk, weight and power of the tool. Debarring tools should be used to reduce risk of cuts and abrasions due to burrs.

WARNING!

1. Always stay cautious when using hand tools, and keep them away from children. Protective eyeware is recommended at all times.
2. Always unplug or disconnect the power source of any appliance or equipment before working on or near conductive surface as severe electrical shock may occur.
3. Select correct types and sizes of hand tool for the job purposes.

CAUTION:



AIR SUPPLY SYSTEM

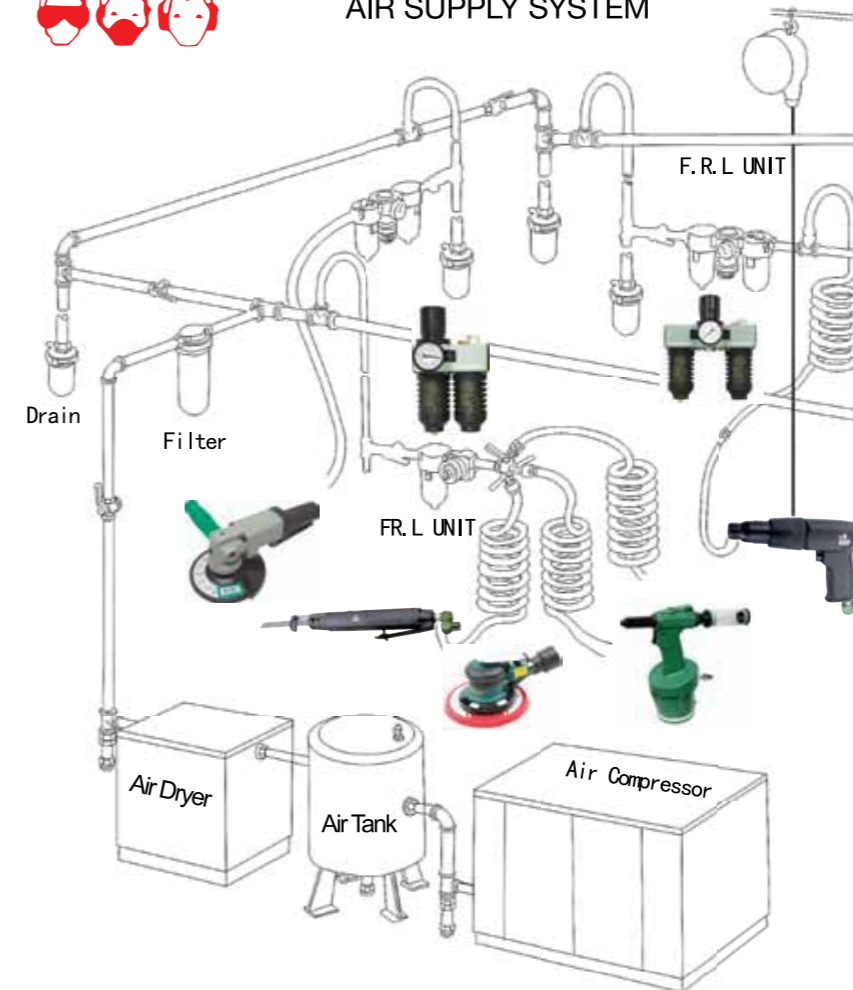

Do not use hand sockets, universal joint or other manual tools with air tools.



It is improper to use hammer or pipe to increase the torque on wrenches, torque wrenches, and ratchet handles.

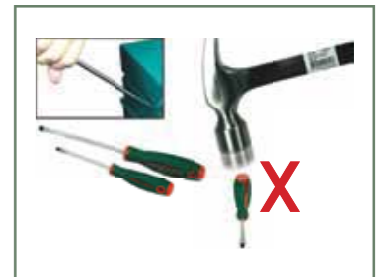

Do not use screwdrivers as pry bar, punch or chisel.

The Air Tools Operation Manual and Six Basic Maintenance Elements

1. Through the tools' air inlet of air pressure, (not from the air pressure of air compressors the regular is 90PSI (6.2kg/cm²) which if it is too high or too low will damage the tools' function and lifetime. Air inlet must have enough lubricating oil (oil#32-#46). In order to help the motor inside the air tool to get the enough lubrication. (Place the blank paper outside the air exhaust to see, it is the normal it there is the greasy dirt which means there is enough oil.) The air inlet must not contain the water. It will not be appropriate if the compressor not dry though the compressed air dryer.
2. Do not disassemble the tools' parts for operation, it will damage the tools and also affect the safety for the operator.
3. Even the tools has small damage or not meet the original functions after using, it is not appropriate to continue use it which it has to be checked immediately.
4. Regular checking (approximately once a week), maintain the tools add the grease to the rotating parts and add the lubricating oil (oil #32-#46) to the motor of the air tools are all necessary to assure the performance.
5. Using the tools must follow the safety regulations and its operation manual.
6. It is important to choose the right and appropriate tools to operate since if the tool is high power will easy to cause the damage of workplace and if the tool is low power will easy to cause the damage of tools.

AB010001	201	AE310048	180	AG010207	212	AI020113	217	AL010025-5	230	AN010227	203	C-A8	34	D71P1150	112	DV13S5125	110	H08MT109S	122	JAG-0913R	148	JAT-6004K	160	M61125	127	P098	97
AB010002	201	AE310049	180	AG010217	214	AI020125	194	AL010025A	228	AN020007	207	C-DBU3	34	D71P138	112	DV13S6150	110	H08MTP09S	122	JAG-0913RM	148	JAT-6673B	159	M62102	127	P106	97
AB010013	201	AE310053	181	AG10001SP	27	AI020127	234	AL010025C	229	AN040042	208	C-DBU7	34	D71P175	112	DV13S8175	110	H08S110S	122	JAG-0973R	148	JAT-6676	159	M62103	127	P107	97
AB010026S	201	AE310072	181	AI010008	186	AI020134	234	AL010027	227	AN040043	208	C-HA	33	D71P180	112	DV41M06S	110	H10121SV	20	JAG-0973RM	148	JAT-6679	159	M62104	127	P116	97
AB020003	202	AE310076	177	AI010012A	186	AI020138	193	AL010028	232	AN040056	239	C-T5	32	D71P2100	112	H01M07SF	120	H10MB08S	123	JAG-0976RM	149	JAT-6905S	161	M62105	127	P118	97
AB030024	202	AE310077	177	AI010017	186	AI020141	193	AL010029	232	AN040062	239	D02AP08S	110	D71P2150	112	H01M08SF	120	H10MB08SP	31	JAG-6608	150	JAT-6946	159	M62106	127	P199LA	106
AB030028	202	AE310082	177	AI010026	216	AI030002	196	AL010030	227	AN040069	222	D04P180	115	D71P2200	112	H01SM109S	120	H10MB10200	123	JAG-6612	151	JAT-6959	161	M63102	127	P199RA	106
AB030038A	202	AE310095	180	AI010030	186	AI030010	195	AL010033	232	AN040074	222	D04P2100	115	D71P2250	112	H01SM209S	120	H10MB2100	123	JAG-6638	151	JAT-6959A	161	M63103	127	P2010SA	106
AB030056	202	AE310110	178	AI010030A	216	AI030014	196	AL010036A	227	AN040087	208	D04P238	115	D71P2300	112	H02MH118S	124	H10MB25100	123	JAH-0288	152	JAZ-0001A	162	M63104	127	P2207A	106
AB030058	202	AE310111	178	AI010033	188	AI030020	196	AL010036N	229	AN040100	207	D04P3125	115	D71P238	112	H02SA109S	119	H10MB3100	123	JAH-6833H	151	JAZ-0001B	162	M63105	127	P2208A	106
AB10001SP	27	AE310117	179	AI010040	186	AI030027	196	AL010039	232	AN040101	208	D04P3150	115	D71P3125	112	H02SM109S	120	H10MB4100	123	JAH-6833HK	151	JAZ-0003B	162	M63106	127	P2210A	106
ACC-608	168	AE310149	179	AI010041	187	AI040005	196	AL010054	233	AN040169	208	D04PP08S	115	D71P3150	112	H02SM209S	120	H10MB5150	123	JAH-6836	152	JAZ-0005A	162	M63106S	127	P2212A	106
ACC-609	168	AE310150	179	AI010042	187	AI040006	196	AL010056	218	AN050014	230	D04PP08SP	26	D71P4200	112	H03MT109S	122	H10MB6150	123	JAH-7102C	152	JAZ-0034B	164	M63108	127	P266	106
AE020002A	170	AE310151	179	AI010060	189	AI040008	197	AL010057	218	AN300001SV	10	D04PP16S	115	D71PP08S	112	H03SA109S	119	H10MB8200	123	JAH-7105	152	JAZ-0034D	164	M64105S	127	P2708	100
AE030002	170	AE310178	230	AI010062	188	AI040017	197	AL010058	219	AN500001SV	10	D04S480	115	D71PP08SP	26	H03SA209S	119	H10MT08SP	31	JA-HVLP-40	166	JAZ-0042	168	M645115SP	31	P2710	100
AE080004	170	AE310205	179	AI010063	187	AI040031	197	AL010061	219	AN500002SV	10	D04S5125	115	D71S250	112	H05SM109S	120	H10MT09S	123	JA-HVLP-40W166	166	JAZ-0045B	164	MF05S	211	P2710SP	25
AE170006	171	AE310206	179	AI010067	188	AI040039	234	AL010062	219	AR020016	183	D04S6100	115	D71S360	112	H05SM1100	121	H10MT10100	123	JAI-0405	140	JAZ-0045D	164	MHS100AG	130	P2803SP	25
AE300002SV	21	AE310207	179	AI010069	233	AI040040	234	AL010063	227	AR020017	183	D04S6150	115	D71S4200	112	H05SM115	121	H10MT15100	123	JAI-0405K	140	JAZ-0514	160	MK2040	124	P2810	100
AE300051	171	AE320023	181	AI010069A	233	AI040041	234	AL010066	232	AR020018	183	D04S638	115	D71S480	112	H05SM120	121	H10MT20100	123	JAI-0501	140	JAZ-0534	160	MT0303	130	P30M07A	102
AE300061	172	AE320024	181	AI010078	187	AI040061	225	AL010067	232	AR020019	183	D04S8150	115	D71S5125	112	H05SM125	121	H10MT25100	123	JAI-0501K	140	JAZ-29510	162	MT0701	130	P30M07C	103
AE300064	171	AE320030	216	AI010079	187	AI050002	197	AL010067B	232	AR020042	182	D3750P06S	116	D71S5150	112	H05SM130	121	H10MT27150	123	JAI-0923	136	JAZ-3713	164	MTC101SP	29	P30M10A	102
AE300072	174	AE320031	216	AI010084	224	AI050004A	198	AL010076	219	AR020060	182	D3750T08S	116	D71S5200	112	H05SM140	121	H10MT30150	123	JAI-0924	136	JAZ-3714	164	MTC1150	128	P30M10C	103
AE300095	172	AE320034	181	AI010090A	189	AI050007A	199	AL010077	227	AR020061	182	D3765P08S	116	D71S5250	112	H05SM150	121	H10MT40150	123	JAI-0936	135	JAZ-3811B	164	MTC1200	128	P32M03S	102
AE300103	172	AG010001	104	AI010100B	233	AI050007B	199	AL010078	228	AR030004	184	D3765T06S	116	D71S5300	112	H05SM160	121	H10MT45200	123	JAI-1014	137	JAZ-3945H	164	MTC1300	128	P32M05A	102
AE300161	172	AG010002	104	AI010104	188	AI050007C	199	AL010079	228	AR030007	184	D70105SP	26	D71S538	112	H05SM180	121	H10MT50200	123	JAI-1044	138	JAZ-6704	160	MTC150	128	P32M05C	103
AE300165	171	AG010002SP	25	AI010115	224	AI050007D	199	AL010080	229	AR030013	184	D70P175	114	D71S575	112	H05SM209S	120	H16109S	119	JAI-1044K	139	M03040	126	MTC155	128	P32M07A	102
AE300176	173	AG010003	104	AI020015	189	AI050008	199	AL010085	229	AR030018	184	D70P2100	114	D71S6100	112	H05SM2100	121	H20MB20100	124	JAI-1054	138	M04008	125	MTC200	128	P32M07C	103
AE300176-A	173	AG010005	104	AI020016	189	AI050024	199	AL010086	233	AR030024	184	D70P238	114	D71S6150	112	H05SM215	121	H20MB2020	124	JAI-1138L	133	M04012	125	MTC2150	128	P32M10A	102
AE300177	173	AG010006	104	AI020017	189	AI050030	199	AL010099	230	AR030031	183	D70P3125	114	D71S638	112	H05SM220	121	H20MB2025	124	JAI-1408L	134	M04016	125	MTC2200	128	P32M10C	103
AE300178	173	AG010008	104	AI020018	190	AI050043	199	AL010102	228	AR040018	184	D70PP07S	114	D71S8150	112	H05SM225	121	H20MB2030	124	JAI-6202	139	M04024	125	MTC2300	128	P36M06C	103
AE300187	173	AG010009	104	AI020019	195	AI050043S	200	AL010103	228	AR060001	185	D70PP10S	114	D71S8175	112	H05SM230	121	H20MB2040	124	JAI-6202K	139	M04032	125	MTC300	128	P36M09A	102
AE300195	174	AG010011	104	AI020020	195	AI050049	199	AL010110	237	AR060015	185	D70S475	114	D71S8200	112	H05SM240	121	H20MB2050	124	JAI-6211	138	M05016	125	MTC306	129	P36M09C	103
AE300197	174	AG010012	104	AI020021	195	AI050067	235	AN010001C	204	AR060017	185	D70S5100	114	D71S8250	112	H05SM250	121	H20MB2060	124	JAI-6211L	138	M05020	125	MTC308	129	P38M11A	103
AE300200	174	AG010026SP	26	AI020024	190	AI050069	217	AN010008	205	AR060021	185	D70S6125	114	D71S9175	112	H05SM260	121	H20MB2080	124	JAR-1064	142	M06030	126	MTC406	129	P4309	107
AE300213	174	AG010030A	210	AI020027	195	AI050070	217	AN010012A	206	AR060032	185	D70S6150	114	D71T10	113	H05SM280	121	JA-23S	168	JAR-6309A	143	M06040	126	MTC408	129	P4314	107
AE310001	175	AG010032	211	AI020034	191	AI050071	217	AN010030A	206	AR060035	185	D70S638	114	D71T107S	113	H06MT109S	122	JA-3808A	168	JAR-6309AK	143	M07016	125	MTC506	129	P4318	107
AE310004	175	AG010033	211	AI020035	191	AI050080	200	AN010038	204	AS-0001A	167	D70S8150	114	D71T109S	113	H06S109S	120	JA-506G	168	JAR-6310A	143	M08012	125	MTC508	129	P4324	107
AE310005	175	AG010034	211	AI020037	191	AI050081	225	AN010045	205	AS-0001D	167	D70S8200	114	D71T15	113	H06S1100	121	JA-507S	167	JAR-6311	143	M08016	125	MTM1025	128	P4330	107
AE310006	175	AG010035	211	AI020040	191	AI050083	218	AN010054A	206	AS-0059A	168	D70S9175	114	D71T20	113	H06S115	121	JA-6111	166	JAR-6311-1	143	M08024	125	MTM1050	128	P4336	107
AE310008	176	AG010037	210	AI020041	191	AI050084	217	AN010064	207	C-3DH2	33	D70S9200	114	D71T25	113	H06S120	121	JA-6111K	166	JAR-6312	144	M08032	125	MTM1075	128	P52M10A	102
AE310010	176	AG010038AL	212	AI020042	191	AI050085	218	AN010064A	207	C-3DH203	33	D70S9250	114	D71T27	113	H06S125	121	JAB-2051	146	JAR-6313	144	M08503SP	26	MTM1100	128	P53M11	103
AE310012	176	AG010039	213	AI020043	195	AI050090	235	AN010066	207	C-3DH262	33	D715N05	113	D71T30	113	H06S130	121	JAB-2052	146	JAS-0452	156	M09300	126	P017	98	P54M10A	103
AE310013	177	AG010041	213	AI020049	190	AI050092	200	AN010070	204	C-5DW1	16	D715N06	113	D71T40	113	H06S140	121	JAB-7023	146	JAS-1009	157	M09500	126	P018	98	P5514	107
AE310015N	177	AG010042	212	AI020050	190	AI050093	200	AN010072	206	C-5DW108	19	D715N07	113	D71T45	113	H06S150	121	JAD-1015	145	JAS-1033-6HE155	157	M09513SP	26	P018SP	25	P5518	

P9920A	104	S03A401SP	24	S03A6123	90	S03A6248	91	S03AD6126	92	S04H4109	68	S04H6122	70
P9920AS	104	S03A4108	88	S03A6124	90	S03A6249	91	S03AD6127	92	S04H4110	68	S04H6123	70
P9920C	104	S03A4109	88	S03A6125	90	S03A6251	91	S03AD6128	92	S04H4111	68	S04H6124	70
P9920CS	104	S03A4110	88	S03A6126	90	S03A6253	91	S03AD6129	92	S04H4112	68	S04H6125	70
PF-20	163	S03A4111	88	S03A6127	90	S03A6254	91	S03AD6130	92	S04H4113	68	S04H6126	70
PF-30	163	S03A4111S	88	S03A6128	90	S03A6256	91	S03AD6131	92	S04H4114	68	S04H6127	70
PF-40	163	S03A4112	88	S03A6129	90	S03A6257	91	S03AD6132	92	S04H4115	68	S04H6128	70
PH-20	163	S03A4113	88	S03A6130	90	S03A6259	91	S03AD6133	92	S04H4116	68	S04H6129	70
PH-30	163	S03A4114	88	S03A6131	90	S03A6260	91	S03AD6134	92	S04H4117	68	S04H6130	70
PH-40	163	S03A4115	88	S03A6132	90	S03A6263	91	S03AD6135	92	S04H4118	68	S04H6132	70
PM-20	163	S03A4116	88	S03A6133	90	S03A6265	91	S03AD6136	92	S04H4119	68	S04H6133	70
PM-30	163	S03A4117	88	S03A6134	90	S03A6267	91	S03AD6137	92	S04H4120	68	S04H6134	70
PM-40	163	S03A4118	88	S03A6135	90	S03A6270	91	S03AD6138	92	S04H4121	68	S04H6135	70
PV018	108	S03A4119	88	S03A6136	90	S03A6A4	92	S03AD6140	92	S04H4122	68	S04H6136	70
PV0506	109	S03A4120	88	S03A6137	90	S03A6A8	92	S03AD6141	92	S04H4123	68	S04H6138	70
PV0508	109	S03A4121	88	S03A6138	90	S03A6E04	92	S03AD6142	92	S04H4124	68	S04H6141	70
PV0510	109	S03A4122	88	S03A6139	90	S03A6E06	92	S03AD6143	92	S04H4125	68	S04H6146	70
PV066	108	S03A4122SP	24	S03A6140	90	S03A6E07	92	S03AD6146	92	S04H4125S	81	S04H6150	70
PV068	108	S03A4123	88	S03A6141	90	S03A6E08	92	S03AD6149	92	S04H4125SP	30	S04H6419	70
PV086	108	S03A4124	88	S03A6142	90	S03A6E10	92	S03AD6150	92	S04H4126	68	S04H6421	70
PV087	108	S03A4125	88	S03A6143	90	S03A6E35	92	S04H2104	66	S04H4127	68	S04H6422	70
PV088	108	S03A4126	88	S03A6144	90	S03A6U6	92	S04H21045	66	S04H4128	68	S04H6424	70
PV106	109	S03A4127	88	S03A6145	90	S03A8226	93	S04H2105	66	S04H4129	68	S04H6426	70
PV1106	108	S03A4128	88	S03A6146	90	S03A8229	93	S04H21055	66	S04H4130	68	S04H6427	70
PV1118	108	S03A4129	88	S03A6147	90	S03A8235	93	S04H2106	66	S04H4132	68	S04H6429	70
PV156	109	S03A4130	88	S03A6148	90	S03A8238	93	S04H2107	66	S04H4134	68	S04H6430	70
PV2810	109	S03A4131	88	S03A6149	90	S03A8241	93	S04H2108	66	S04H4136	68	S04H6432	70
R0602	41	S03A4132	88	S03A6150	90	S03A8A12	93	S04H2109	66	S04H4317SP	22	S04H6433	70
R0603	41	S03A4208	88	S03A6151	90	S03A8A6	93	S04H2110	66	S04H458S	81	S04H6435	70
R1206	41	S03A4210	88	S03A6152	90	S03A8E04	93	S04H2111	66	S04H4724S	81	S04H6436	70
R2902	40	S03A4211	88	S03A6153	90	S03A8E06	93	S04H2112	66	S04H4908	69	S04H6438	70
R2903	40	S03A4213	88	S03A6154	90	S03A8E07	93	S04H2113	66	S04H4909	69	S04H6441	70
R2904	40	S03A4214	88	S03A6155	90	S03A8E08	93	S04H2118S	85	S04H4910	69	S04H6444	70
R3602	40	S03A4216	88	S03A6156	90	S03A8E10	93	S04H2125S	85	S04H4911	69	S04H6446	70
R3603	40	S03A4217	88	S03A6157	90	S03A8E12	93	S04H2125SP	23	S04H4912	69	S04H6447	70
R3604	40	S03A4219	88	S03A6158	90	S03A8E13	93	S04H2141S	85	S04H4913	69	S04H6450	70
R3702	40	S03A4221	88	S03A6159	90	S03A8U8	93	S04H3106	67	S04H4914	69	S04H6456	70
R3703	40	S03A4222	88	S03A6160	90	S03AD4110	89	S04H3107	67	S04H4915	69	S04HD2104	66
R3704	40	S03A4222SP	24	S03A6163	90	S03AD4111	89	S04H3108	67	S04H4916	69	S04HD21045	66
R3802	40	S03A4224	88	S03A6165	90	S03AD4111S	89	S04H3109	67	S04H4917	69	S04HD2105	66
R3803	40	S03A4226	88	S03A6167	90	S03AD4112	89	S04H3110	67	S04H4918	69	S04HD21055	66
R3804	40	S03A4227	88	S03A6170	90	S03AD4113	89	S04H3111	67	S04H4919	69	S04HD2106	66
R4202	40	S03A4229	88	S03A6217	91	S03AD4114	89	S04H3112	67	S04H4920	69	S04HD2107	66
R4203	40	S03A4230	88	S03A6219	91	S03AD4116	89	S04H3113	67	S04H4921	69	S04HD2108	66
R4204	40	S03A4232	88	S03A6221	91	S03AD4117	89	S04H3114	67	S04H4922	69	S04HD2109	66
R4802	41	S03A4A3	89	S03A6222	91	S03AD4119	89	S04H3115	67	S04H4923	69	S04HD2110	66
R4803	41	S03A4A6	89	S03A6224	91	S03AD4121	89	S04H3116	67	S04H4924	69	S04HD2111	66
R4804	41	S03A4E10	89	S03A6226	91	S03AD4124	89	S04H3117	67	S04H4925	69	S04HD2112	66
R4902	41	S03A4E3	89	S03A6227	91	S03AD4303S	95	S04H3118	67	S04H4926	69	S04HD2113	66
R4903	41	S03A4E4	89	S03A6229	91	S03AD4317	95	S04H3119	67	S04H4927	69	S04HD3106	67
R4904	41	S03A4E5	89	S03A6230	91	S03AD4319	95	S04H3120	67	S04H4928	69	S04HD3107	67
R5104	41	S03A4E6	89	S03A6232	91	S03AD4321	95	S04H3120S	84	S04H4929	69	S04HD3108	67
R6602	39	S03A4E8	89	S03A6233	91	S03AD6117	92	S04H3121	67	S04H4930	69	S04HD3109	67
R6603	39	S03A4FL14SV	11	S03A6235	91	S03AD6118	92	S04H3122	67	S04H4932	69	S04HD3110	67
R6604	39	S03A4U4	89	S03A6236	91	S03AD6119	92	S04H3124	67	S04H524127S	83	S04HD3111	67
RD01032S	117	S03A6117	90	S03A6238	91	S03AD6120	92	S04H3125S	84	S04H52460S	82	S04HD3112	67
RD02040S	117	S03A6118	90	S03A6240	91	S03AD6121	92	S04H3157S	84	S04H52482S	82	S04HD3113	67
RD0502	39	S03A6119	90	S03A6241	91	S03AD6122	92	S04H3157SP	30	S04H52494S	83	S04HD3114	67
RD0503	39	S03A6120	90	S03A6243	91	S03AD6123	92	S04H3536S	84	S04H6119	70	S04HD3115	67
RD05H2	39	S03A6121	90	S03A6244	91	S03AD6124	92	S04H3536SP	30	S04H6121	70	S04HD3116	67
RD05H22S	39	S03A6122	90	S03A6246	91	S03AD6125	92	S04H4108	68	S04H6121S	81	S04HD3117	67

S04HD3118	67	S05H4814	72	S07H355	73	S09H305	75	S15H6109	78	S24H8400	79	S68H4118	63
S04HD3119	67	S05H4815	72	S07H360	73	S09H3055	75	S15U43S	78	S27H2	79	S68H4119	63
S04HD3120	67	S05H4817	72	S07H4118SP	23	S09H306	75	S16A4506	94	S27H3	79	S68H4120	63
S04HD3121	67	S05H4819	72	S07H420	73	S09H307	75	S16A4508	94	S27H4	79	S68H4121	63
S04HD3122	67	S05H4821	72	S07H425	73	S09H308	75	S16A4510	94	S29H2133S	118	S68H4122	63
S04HD3124	67	S05H4916S	86	S07H427	73	S09H310	75	S16A4512	94	S29H4140S	118	S68H4123	63
S04HD4108	68	S05HD2105	72	S07H430	73	S09H312	75	S16A4514	94	S29H4140SP	24	S68H4124	63
S04HD4109	68	S05HD2106	72	S07H4320	73	S09H314	75	S16A4516	94	S40H108	80	S68H4125	63
S04HD4110	68	S05HD2107	72	S07H4325	73	S09H404	75	S16A4518	94	S40H109	80	S68H4126	63
S04HD4111	68	S05HD2108	72	S07H4327	73	S09H405	75	S16H1034	78	S40H110	80	S68H4127	63
S04HD4112	68	S05HD2109	72	S07H4330	73	S09H406	75	S16H1234	78	S40H111	80	S68H4127S	64
S04HD4113	68	S05HD2110	72	S07H4340	73	S09H407	75	S16H1238	78	S40H112	80	S68H4128	63
S04HD4114	68	S05HD2111	72	S07H4345	73	S09H408	75	S16H1438	78	S40H113	80	S68H4129	63
S04HD4115	68	S05HD2112	72	S07H4350	73	S09H410	75	S16H302	78	S40H114	80	S68H4130	63
S04HD4116	68	S05HD2113	72	S07H4355	73	S09H4118SP	23	S16H304	78	S60H4304S	79	S68H4132	63
S04HD4117	68	S06A408S	94	S07H4360	73	S09H412	75	S16H3410	78	S64H4126S	87	S68H523411S64	
S04HD4118	68	S06H204	71	S07H4370	73	S09H414	75	S16H3412	78	S68H2103	62	SF-20	163
S04HD4119	68	S06H205	71	S07H440	73	S09H416	75	S16H3812	78	S68H2104	62	SF-20A	163
S04HD4120	68	S06H206	71	S07H445	73	S09H4304	75	S16H403	78	S68H21045	62	SF-30	163
S04HD4121	68	S06H207	71	S07H450	73	S09H4305	75	S17H4116	79	S68H2105	62	SF-30A	163
S04HD4122	68	S06H208	71	S07H455	73	S09H4306	75	S17H4121	79	S68H21055	62	SF-40	163
S04HD4123	68	S06H308	71	S07H460	73	S09H4307	75	S17M3116	79	S68H2106	62	SH-20	163
S04HD4124	68	S06H310	71	S07H470	73	S09H4308	75	S17M3121	79	S68H21065	62	SH-20A	163
S04HD4125	68	S06H310S	87	S07H4932S	87	S09H4310	75	S17M4116	79	S68H2107	62	SH-30	163
S04HD4126	68	S06H311	71	S08H206	74	S09H4312	75	S17M4121	79	S68H2108	62	SH-30A	163
S04HD4127	68	S06H312	71	S08H207	74	S09H4314	75	S18A4117	95	S68H2109	62	SH-40	163
S04HD4128	68	S06H314	71	S08H208	74	S09H4316	75	S18A4117M	95	S68H2110	62	SM-20	163
S04HD4130	68	S06H316	71	S08H208S	118	S09H4930S	87	S18A4119	95	S68H2111	62	SM-20A	163
S04HD4710	69	S06H											

V1402	105	W26106	50	W26413PR	51	W26467	51	W43B111	54	W6511012	53	W72132	58
V1501	105	W26107	50	W26414	51	W26468	51	W43B112	54	W6511113	53	W72133	58
V1503	105	W26108	50	W26414PR	51	W26470	51	W43B113	54	W6511315	53	W72134	58
W03112SP	22	W26109	50	W26414S	52	W26470PR	51	W43B114	54	W6511417	53	W72135	58
W230607	46	W26110	50	W26415PR	51	W26FL34SV	12	W43B115	54	W6511618	53	W72136	58
W230809	46	W26111	50	W26416	51	W27AR10	55	W43B116	54	W6511922	53	W72138	58
W230810	46	W26112	50	W26416PR	51	W27AR8	55	W43B117	54	W66107S	45	W72140	58
W231011	46	W26112S	52	W26417	51	W27AS10	55	W43B118	54	W66108	45	W72141	58
W231012	46	W26113	50	W26417PR	51	W27AS12	55	W43B119	54	W66109	45	W72142	58
W23108S	46	W26114	50	W26418PR	51	W27AS15	55	W45107S	43	W66110	45	W72143	58
W23108SP	22	W26114S	52	W26419	51	W27AS18	55	W45108	43	W66111	45	W72144	58
W231113	46	W26115	50	W26419PR	51	W27AS4	55	W45109	43	W66112	45	W72145	58
W231213	46	W26116	50	W26420PR	51	W27AS6	55	W45110	43	W66113	45	W72146	58
W231214	46	W26116S	52	W26421	51	W27AS8	55	W45110S	44	W66114	45	W72147	58
W231415	46	W26116SP	31	W26421PR	51	W27AT10	55	W45111	43	W66115	45	W72148	58
W231617	46	W26117	50	W26422	51	W27AT12	55	W45112	43	W66117	45	W72150	58
W231719	46	W26118	50	W26422PR	51	W27AT15	55	W45112SP	22	W66119	45	W72152	58
W231819	46	W26119	50	W26423PR	51	W27AT4	55	W45113	43	W66207S	45	W72155	58
W231921	46	W26120	50	W26424	51	W27AT6	55	W45114	43	W67104S	46	W72160	58
W231922	46	W26121	50	W26424PR	51	W27AT8	55	W45115	43	W680809	45	W72165	58
W232022	46	W26122	50	W26425	51	W2808	57	W45116	43	W680810	45	W72170	58
W232123	46	W26123	50	W26425PR	51	W2810	57	W45117	43	W681011	45	W72175	58
W232427	46	W26124	50	W26426PR	51	W2812	57	W45117S	44	W681213	45	W72180	58
W233032	46	W26125	50	W26427	51	W2814	57	W45118	43	W681415	45	W72185	58
W240809	47	W26126	50	W26427PR	51	W2818	57	W45119	43	W681618	45	W72190	58
W240810	47	W26126S	52	W26428PR	51	W2824	57	W45121	43	W681719	45	W72195	58
W241011	47	W26127	50	W26429PR	51	W2836	57	W45122	43	W71106	49	W84106	60
W241012	47	W26128	50	W26430	51	W2848R	57	W45123	43	W71107	49	W84107	60
W24106S	47	W26129	50	W26430PR	51	W28A14	57	W45124	43	W71108	49	W84108	60
W241213	47	W26130	50	W26431	51	W28A18	57	W45208S	43	W71109	49	W84108S	60
W241214	47	W26132	50	W26432	51	W28A24	57	W45308SP	22	W71110	49	W84109	60
W241314	47	W26133	50	W26432PR	51	W28A36	57	W45508S	44	W71111	49	W84110	60
W241417	47	W26134	50	W26433	51	W28A48	57	W47108SP	22	W71112	49	W84111	60
W241617	47	W26135	50	W26434	51	W28HD10	56	W47708SP	22	W71113	49	W84112	60
W241719	47	W26136	50	W26434PR	51	W28HD12	56	W51108	44	W71114	49	W84113	60
W241922	47	W26138	50	W26435	51	W28HD14	56	W51109	44	W71115	49	W84114	60
W242123	47	W26141	50	W26436	51	W28HD8	56	W51110	44	W71116	49	W84115	60
W242224	47	W26143	50	W26436PR	51	W290608	48	W51111	44	W71117	49	W84116	60
W242427	47	W26145	50	W26437	51	W290711	48	W51112	44	W71118	49	W84117	60
W243032	47	W26146	50	W26438	51	W291012	48	W51113	44	W71119	49	W84118	60
W243236	47	W26148	50	W26438PR	51	W291418	48	W51114	44	W71120	49	W84119	60
W243641	47	W26150	50	W26441	51	W291622	48	W51115	44	W71121	49	W84120	60
W250607	48	W26155	50	W26441PR	51	W292024	48	W51116	44	W71122	49	W84121	60
W250809	48	W26160	50	W26443	51	W32206S	47	W51117	44	W71123	49	W84122	60
W250810	48	W26165	50	W26446	51	W43A0607	54	W51118	44	W71124	49	W84123	60
W251011	48	W26170	50	W26446PR	51	W43A0809	54	W51119	44	W71125	49	W84124	60
W251012	48	W26406	51	W26448	51	W43A1011	54	W53216	52	W71127	49	W84125	60
W25108S	48	W26406PR	51	W26450	51	W43A1012	54	W53217	52	W71128	49	W84126	60
W251113	48	W26407PR	51	W26450PR	51	W43A106S	54	W53219	52	W71130	49	W84127	60
W251213	48	W26408	51	W26452	51	W43A107SP	24	W610810	53	W71132	49	W84128	60
W251214	48	W26408PR	51	W26453	51	W43A1213	54	W611011	53	W721105	58	W84129	60
W251415	48	W26409PR	51	W26455	51	W43A1214	54	W611012	53	W721110	58	W84130	60
W251417	48	W26410	51	W26455PR	51	W43A1415	54	W61106S	53	W72122	58	W84132	60
W251617	48	W264108PRS	52	W26457	51	W43A1417	54	W611214	53	W72123	58	W86112S	61
W251819	48	W26410PR	51	W26459	51	W43A1617	54	W611315	53	W72124	58		
W251922	48	W26411	51	W26460	51	W43A1719	54	W611417	53	W72125	58		
W252022	48	W26411PR	51	W26460PR	51	W43A1819	54	W611618	53	W72126	58		
W252123	48	W26411PRS	52	W26462	51	W43A2022	54	W611719	53	W72127	58		
W252224	48	W26411SA	52	W26463	51	W43B108	54	W612224	53	W72128	58		
W252427	48	W26412PR	51	W26465PR	51	W43B109	54	W6510810	53	W72129	58		
W253032	48	W26413	51	W26466	51	W43B110	54	W6511011	53	W72130	58		

JONNESWAY is the RIGHT WAY



Authorised Agent/Distributor